

The logo features a stylized arrow pointing upwards, enclosed within a circular shape that resembles a vacuum cleaner's head. The arrow is white with a grey outline, and the circular shape is grey with a white outline.

Arrow Backpack Vacuum

PACIFIC

Manual

The contents of this manual are based on the latest product information available at the time of publication. Pacific reserves the right to make changes or improvements to its machines without notice.

Carefully inspect all components to ensure that there is no concealed freight damage. If such damage is discovered, file a "CONCEALED DAMAGE REPORT" immediately with the delivering carrier.

FOR YOUR CONVENIENCE, RECORD THE FOLLOWING IMPORTANT INFORMATION:

For new manuals write to:

Pacific
2259 S. Sheridan
Muskegon, MI 49442-6252

SERIAL NUMBER

DATE PURCHASED

or download the most recent version of the manuals from our website:

www.pacificfloorcare.com



READ AND UNDERSTAND ALL WARNINGS AND INSTRUCTIONS BEFORE USING THIS MACHINE!



WARNING! To reduce the risk of fire, electric shock, or injury:

- 1) You must be trained to operate this machine. This machine is to be operated for its intended use only.
- 2) Do not use outdoors or on wet surfaces.
- 3) Do not operate this machine unless it is completely assembled.
- 4) Always use a three-wire electrical system connected to the electrical ground. For maximum protection against electrical shock, use a circuit that is protected by a ground fault circuit interrupter. Consult your electrical contractor.
- 5) To prevent electrical shock: Always remove the electrical plug from the electrical outlet before performing any repairs, maintenance or cleanup and when leaving the machine unattended.
- 6) To prevent electrical shock: Keep the machine surface dry; Do not subject to rain; Store the machine in a dry building area; Clean the machine with a dry cloth only.
- 7) Machines can cause an explosion when near flammable materials and vapors. Do not use or store this machine with or near fuels, grain dust, solvents, thinners, or other flammable materials. Do not use flammables to clean this machine.
- 8) Maintenance and repairs must be done by a qualified or authorized person.
- 9) If the machine is not working as it should, has been dropped, damaged, left outdoors, or dropped into water, return it to a service center.
- 10) Do not use with damaged cord or plug.
- 11) Turn off all controls before unplugging.
- 12) Do not use without a dust bag and/or filters in place.
- 13) Make sure all labels, decals, warnings, cautions and instructions are fastened to the machine.



GROUNDING INSTRUCTIONS:

This machine must be grounded. If it should malfunction or break down, grounding provides a path of least resistance for electric current to reduce the risk of electric shock. This machine is equipped with a cord having an equipment-grounding conductor and grounding plug. The plug must be inserted into an appropriate outlet that is properly installed and grounded in accordance with all local codes and ordinances.



WARNING! - Improper connection of the equipment-grounding conductor can result in a risk of electric shock. Check with a qualified electrician or service person if you are in doubt as to whether the outlet is properly grounded. Do not modify the plug provided with the machine - if it will not fit the outlet; have a proper outlet installed by a qualified electrician.

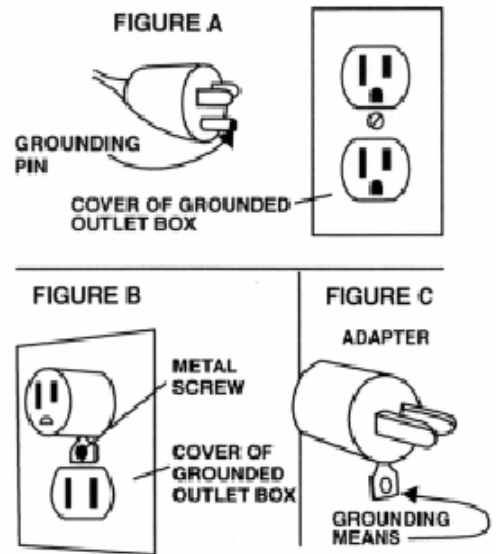

This machine is for use on a nominal 120-volt circuit, and has a grounded plug that looks like the plug illustrated in figure A. A temporary adapter that looks like the adapter illustrated in figures B and C may be used to connect this plug to a 2-pole receptacle as shown in figure B if a properly grounded outlet is not available. The temporary adapter should be used only until a properly grounded outlet (figure A) can be installed by a qualified electrician. The green colored rigid ear, lug, or the like extending from the adapter must be connected to a permanent ground such as a properly grounded outlet box cover. Whenever the adapter is used, it must be held in place by a metal screw.

NOTE: In Canada, the use of a temporary adapter is not permitted by the Canadian Electrical Code

EXTENSION CORDS:

Use only three-wire 16/3 or larger gauge approved extension cords that have three-prong grounding type plugs and three-pole receptacles that accept the appliance's plug. Replace or repair any damaged cords or plugs.



THERMAL-PROTECTION INSTRUCTIONS:

This vacuum cleaner is equipped with a thermal-protection device, which will interrupt vacuum motor circuit automatically to prevent the motor from overheating. Air restrictions for an extended period will result in the vacuum motor shutting down. If this occurs, press the switch to turn the vacuum to the OFF position and wait a minimum of 5 minutes for the motor to cool to a safe temperature. Be sure to determine the cause of overheating and rectify the problem before using the vacuum cleaner again or it will continue to overheat and shut down. In some instances the vacuum motor circuit is interrupted because of high motor temperature caused by a dirty dust bag or an airway blockage. Please unplug the vacuum and check the inner paper dust bag and airway. If the dust bag is too dirty and clogged, replace it with a new one. If an airway is blocked, please remove the blockage before reuse. The motor can be restarted when it is cool.

REPAIR SERVICE:

When servicing, use an authorized person only. Use only identical replacement parts.

PREPARATION FOR OPERATION:

Please refer to drawing 1

- 1) Remove the cover (Item # 34) and cover seal ring (Item # 33), pull out the cloth filter bag (Item # 31). Check to see that the filter guards (Item # 1, Item # 2 and Item # 3) have not shifted during shipping.
- 2) Install an inner paper dust bag (Item # 32) inside of the outer cloth filter bag (Item # 31). At the beginning of each shift, the bags should be checked. Empty or replace as necessary.
- 3) Note: never use a paper dust bag without the cloth dust bag.
- 4) Place the cover seal ring (Item # 33) on the dust bag's opening (Item # 32).
- 5) Replace the cover (Item # 34) and clip the sunken edge of the cover tight by pushing downward the cover clip (Item # 7).
- 6) Push the connector tube (Item # 35) into the cover (Item # 34).
- 7) Check the wear on the cord by the vacuum body and at the plug. Pass the power supply cord (Item # 13) through the strip outside the left side of the waist belt (Item # 39).
- 8) Fix the switch box under the sewn strap and knot the other strap around the switch box.
- 9) Adjust the shoulder strap to allow the waist belt to be buckled around your waist.
- 10) Fasten the waist belt and chest belt snugly and make sure the weight is resting comfortably on your hips. NOTE: The back-plate is adjustable up or down by removing the four screws (Item # 27) that attach to the vacuum body (Item # 28).



OPERATING PROCEDURES



WARNING! - For the safe operation of this machine follow the instructions given in this booklet and the training given by your supervisor. Failure to do so can result in personal injury and/or damage to machine and property!

DO NOT OPERATE MACHINE IN AN EXPLOSIVE ENVIRONMENT!



WARNING! - NEVER USE THIS MACHINE TO PICK UP VOLATILE, EXPLOSIVE OR HAZARDOUS MATERIALS.

OPERATION

To prepare the machine for operation, make sure it is of the correct voltage and properly assembled. If in doubt, ask your supervisor.

FOR DRY PICK-UP ONLY:

“Dry” refers to material such as dust, dirt, debris and dry foam shampoo.

- 1) Plug the power cord into a 120-volt, 60 cycle grounded outlet.
- 2) Turn the machine's motor on by pressing the rocker switch which is located on the power cord.



Good maintenance procedures assure better operation, fewer repairs and longer life for your machine.



WARNING! - DISCONNECT THE ELECTRICAL PLUG OF THE MACHINE FROM THE ELECTRICAL OUTLET BEFORE DOING ANY CLEANUP, REPAIRS OR MAINTENANCE OF THE MACHINE AND WHEN LEAVING THE MACHINE UNATTENDED.

CLEAN THE MACHINE AFTER EACH USE:

- 1) Each week, rinse, dry and return the foam (Item # 22) at the bottom of the vacuum tank below the vacuum motor.
- 2) Clean the vacuum tank: Release the clamps on each side of the top of the vacuum tank. Lift the filter assembly out of the vacuum tank and set aside. Wipe the inside and outside of the vacuum tank with a clean dry cloth.
- 3) Empty and check the filter assembly: Empty the recovered soilage into a suitable container and remove and shake the cloth filter bag to remove clinging dirt. Lightly brush the inside of the cloth filter bag to remove embedded dirt. Check the cloth filter bag for tears or holes; repair or replace if necessary. Install a clean paper dust bag into assembly into the cloth filter bag and place them back into the vacuum tank.

ELECTRICAL CABLE:

Check the cord for any nicks, cuts or damage. Report these to your supervisor for correction.

VACUUM TANK ASSEMBLY:

- 1) Gaskets: Clean the Cover Seal Ring gasket.
- 2) Vacuum Motor Guards: Inspect for dirt or damage and replace if damaged or filled with dirt.



FILTER MAINTENANCE:

- 1) Check the paper dust bag (Item # 32) each time you start and finish vacuuming. A clogged and dirty dust bag restricts airflow and results in reduced suction and overheating.
- 2) While vacuuming, stop every two hours or as needed to shake out the paper dust bag (Item # 32). Replace the paper dust bag when necessary. Note: Lift both paper dust bag and cloth filter bag out at the same time to avoid ripping the paper dust bag, especially when it is full.
- 3) Once a month (or more often if necessary) hand or machine wash the cloth dust bag (Item # 31) and let it AIR DRY. DO NOT PUT IT IN A DRYER.
- 4) Once a month, or more often if necessary, clean the foam filter (Item # 2) between the motor guards, located inside the vacuum tank under the paper and cloth dust bag. To do this remove the top piece of the motor guard (Item # 1) and remove the foam filter (Item # 2). Shake it out, rinse it and let it air dry thoroughly. Before the next use, re-install a DRY foam filter (Item # 2). Replace with new foam filter if it becomes worn or damaged. Re-install motor guard (Item # 1) by firmly snapping the guard in place.
- 5) Each week rinse and air dry the foam filter (Item # 22) at the bottom of the vacuum tank below the vacuum motor. To do this pull out the round rubber support (Item # 21) and remove foam filter (Item # 22). Rinse the foam filter and let it air dry thoroughly. Before the next use, re-install foam filter (Item # 22) then reinstall round rubber support (Item # 22) into the canister to support the foam filter.



Vacuum Assembly

Drawing 1

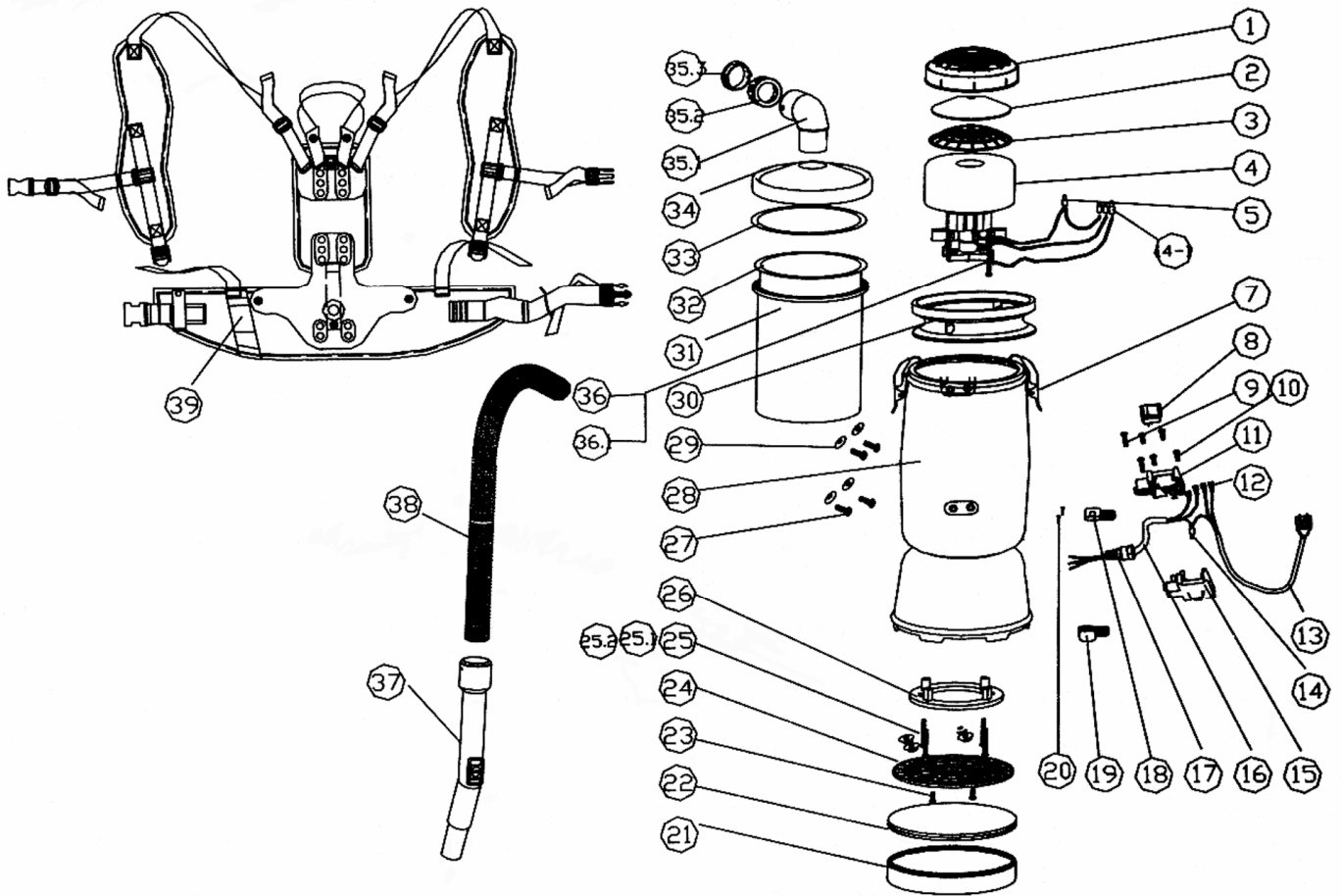



PACIFIC

VACUUM ASSEMBLY		
ITEM	PART NO.	DESCRIPTION
1	633840	Motor Guard
2	633340	Foam Filter
3	633841	Motor Guard
4	635240	Vacuum Motor
5	911434	Thermal Protector
7	635140	Cover Latch
8	911435	Rocker Switch
9	964202	Screw (M3 x 25)
10	964203	Screw (M3 x 12)
11	631340	Upper Switch Box
12	911436	Connector Terminal and Insulator
13	908110	Power Supply Cords and Cord Sets
14	911437	Wire Connector
15	631341	Lower Switch Box
16	908111	Connection Cord
17	632040	Connection Cable Clamp Nut
18	632041	Connection Cable Clamp Part 1
19	632042	Connection Cable Clamp Part 2
20	964204	Screw (M3 x 12)
21	638540	Round Rubber Support
22	635640	Sound Muffler (Foam Filter)
23	964205	Screw (M3 x 10)
24	633842	Plastic Guard
25	964206	Screw (M5 x 40) and Washer
26	637340	Motor Clamping Ring
27	964207	Screw (M8 x 15)
28	638640	Vacuum Tank
29	980664	Washer
30	637341	Rubber Ring
31	630641	Cloth Filter Bag
32	630640	Paper Dust Bag
33	637342	Cover Seal Ring
34	632341	Cover
35.1	632440	Hose Cuff
35.2	632441	Hose Cuff Screw
35.3	632442	Screw Cuff
36	911438	Wire Connector
37	633940	Handle
38	634140	Hose
39	634540	Backpack Harness



WARRANTY POLICY PACIFIC LIMITED WARRANTY

The **Pacific** Arrow Backpack Vacuum has been manufactured, tested and inspected in accordance with specific engineering requirements. This machine is **WARRANTED** to be free from defects in workmanship and materials for periods as follows from the date of purchase.

One (1) Year Parts & Labor – unless excluded below

This warranty extends to the original user/purchaser and only when used, operated and maintained in accordance with **Pacific** Operating and Maintenance instructions.

This warranty does not apply to certain wear parts and accessories of the machine such as electrical cords, carbon motor brushes, floor brushes, belts, hoses, tools, squeegee blades, filters etc., nor does it apply to damage or failure caused by improper use, abuse or neglect. Warranty credit of return parts including motors, etc., is subject to incoming inspection of those items.

To secure repair under this warranty, the following procedure should be taken:

- 1) The inoperative machine or warranted part must be delivered to the authorized dealer with shipping and delivery charges prepaid. If unable to locate the Dealer, you may contact **Pacific** at the address listed herein for the location of the nearest **Pacific** repair center or agent or for other instructions pertaining to your warranty difficulty.
- 2) Upon compliance with the above warranty procedure, all warranted repairs will be completed at no additional charge or cost to the user.
- 3) Only **Pacific** or its authorized dealers and agents may make no charge warranty repairs on this product. All others do so at their own risk.

This warranty limits **Pacific** liability to the repair of the product and/or warranted parts replacement and does not include incidental or consequential damages arising from the use of a **Pacific** machine whether defective or not.

This warranty is in lieu of all other expressed or implied warranties and is extended to the original purchaser/user.