



**PACIFIC**<sup>™</sup>  
F L O O R C A R E

**PURPOSE BUILT.**<sup>™</sup>

# **PARTS & OPERATING MANUAL**

## **B-1500 BURNISHER 1500 RPM WITH ABS BASE**

**PLEASE READ THIS BOOK**

---

This operator's book has important information for the use and safe operation of this machine. Read this book carefully before starting the machine. Keep this book and tell all operators to read the book. If you do not follow the instructions, you can cause an injury or damage equipment, furniture or buildings.

For new books, please download your copy from our website [www.pacificfloorcare.com](http://www.pacificfloorcare.com) or write to:

***Pacific Floorcare***  
*2259 S. Sheridan Drive*  
*Muskegon, MI 49442-6252*

Carefully inspect all components to ensure that there is no concealed freight damage. If such damage is discovered, file a "CONCEALED DAMAGE REPORT" immediately with the delivering carrier.

The contents of this manual are based on the latest product information available at the time of publication. Pacific reserves the right to make changes or improvements without notice.

**Thank you for purchasing a Pacific Floorcare product. Warranty registration will allow us to better serve you over the lifetime of the product. For quick and easy registration, go to:  
[www.pacificfloorcare.com/Register Product](http://www.pacificfloorcare.com/Register Product).**

# IMPORTANT SAFETY INSTRUCTIONS

To ensure the safe operation of this machine, you must read and understand all warnings and instructions in this book. If you do not understand, ask your supervisor.

## READ ALL INSTRUCTIONS BEFORE USING THIS MACHINE

### **WARNING: To reduce the risk of fire, electric shock, or injury:**

1. You must be trained to operate this machine. This machine is to be operated for its intended use only.
2. Do not operate this machine unless it is completely assembled.
3. Always use a three-wire electrical system connected to the electrical ground. For maximum protection against electrical shock, use a circuit that is protected by a ground fault circuit interrupter. Consult your electrical contractor.
4. To prevent electric shock, always remove the electrical plug from the electrical outlet before doing any repairs or maintenance and when leaving the machine unattended.
5. To prevent electric shock, keep the machine surface dry. Do not subject to rain. Store the machine in a dry building area. Clean the machine with a dry cloth only.
6. Machines can cause an explosion when near flammable materials and vapors. Do not use this machine with or near fuels, grain dust, solvents, thinners, or other flammable materials. Do not use flammables to clean this machine.
7. A qualified or authorized person must do maintenance and repairs.
8. To prevent damage to the power cord, do not move this machine over the power cord. Always lift the power cord over the machine. Do not pull or carry cord, use cord as a handle, close a door on cord, or pull cord around sharp edges or corners. Keep cord away from heated surfaces.
9. Do not use with damaged cord or plug. If the machine is not working as it should, has been dropped, damaged, left outdoors, or dropped into water, return it to a service center.

### **Grounding Instructions**

This machine must be grounded. If it should malfunction or break down, grounding provides a path of least resistance for electric current to reduce the risk of electric shock. This machine is equipped with a cord having an equipment-grounding conductor and grounding plug. The plug must be inserted into an appropriate outlet that is properly installed and grounded in accordance with all local codes and ordinances.

**WARNING** - Improper connection of the equipment-grounding conductor can result in a risk of electric shock.

Check with a qualified electrician or service person if you are in doubt as to whether the outlet is properly grounded. Do not modify the plug provided with the machine - if it will not fit the outlet, have a proper outlet installed by a qualified electrician.

This machine is for use on a nominal 120-volt circuit, and has a grounded plug that looks like the plug illustrated in figure A. A temporary adapter that looks like the adapter illustrated in figures B and C may be used to connect this plug to a 2-pole receptacle as shown in figure B if a properly grounded outlet is not available. The temporary adapter should be used only until a properly grounded outlet (figure A) can be installed by a qualified electrician. The green colored rigid ear, lug, or the like extending from the adapter must be connected to a permanent ground such as a properly grounded outlet box cover. Whenever the adapter is used, it must be held in place by a metal screw. NOTE: In Canada, the use of a temporary adapter is not permitted by the Canadian Electrical Code

### **EXTENSION CORDS**

Use only three-wire 12/3 or larger gauge approved extension cords that have three-prong grounding type plugs and three-pole receptacles that accept the appliance's plug. Replace or repair any damaged cords or plugs.

When servicing, refer to authorized person only. Use only identical replacement parts.

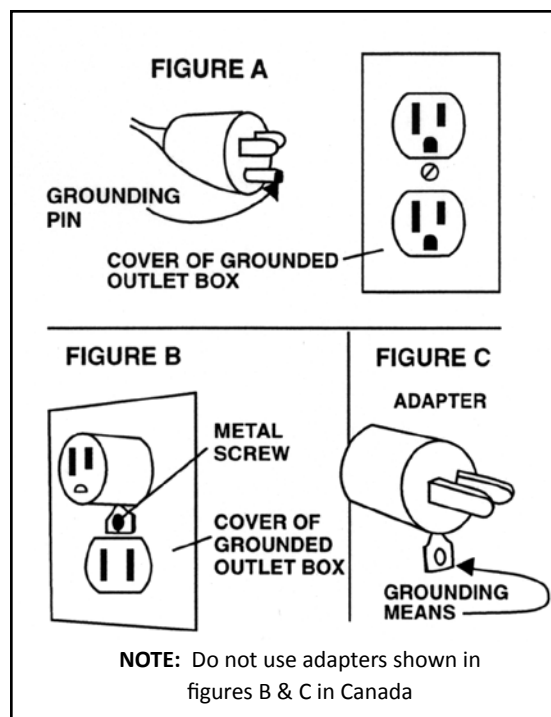

# OPERATING PROCEDURES

---

**WARNING!** For the safe operation of this machine follow the instructions given in this booklet and the training given by your supervisor. Failure to do so can result in personal injury and/or damage to machine and property!

## **DO NOT OPERATE MACHINE IN AN EXPLOSIVE ENVIRONMENT!**

The models shown in this manual are intended for commercial use. THIS MACHINE IS NOT INTENDED FOR SPRAY BUFFING. USING THIS UNIT FOR SPRAY BUFFING WILL VOID WARRANTY.

## **PREPARATION**

To prepare the machine for operation, make sure it is of correct voltage and properly assembled. If in doubt, ask your supervisor.

Your new floor machine operates in a straight-line forward motion, rather than the normal side to side motion of a conventional single disc machine. Be prepared by having your floor area cleared and ready for the fast action of a burnisher.

Prepare the floor area by sweeping, dusting or mopping as needed. Check the proper application recommendations and procedures found on the label of your finish container. **IF IN DOUBT, CALL YOUR SUPERVISOR .**

## **WARNING! NEVER USE THIS MACHINE WITH FLAMMABLE OR EXPLOSIVE MATERIAL!**

For Burnishing: Select the correct clean floor pad (your supplier can help you). The lighter color floor pads (buff or white) are normally used for the burnishing procedure.

## **NEVER OPERATE THE MACHINE WITHOUT THE FLOOR PAD INSTALLED!**

It is very important to select clean, dry pads of uniform thickness. Pads with high or low sections, or hard or soft spots are unacceptable. Pads of open weave are recommended; because close weaves tend to load up fast, bog down the machines, cause circuits to overload and generally give poor results.

Unplug the machine from the wall outlet and then tip the machine back to expose the pad driver. Remove the pad center lock ring. Carefully center the pad onto the pad driver and secure with the locking ring. Check for level, centering and flatness.

## **OPERATION**

Set the machine upright onto the pad. Plug the machine's power cable into a properly grounded outlet (see Safety Instructions). Next, release the handle by unlocking the knob and allow the handle to lower into a comfortable position. **THEN ALWAYS SECURE THE HANDLE LOCKING KNOB.** This will allow the operator to easily control the pad pressure.

Depress the handle slightly to elevate the pad from the floor. This is to avoid burning the floor on initial start up, before the operator is ready to move forward. Pull out on the "Watch Dog" Safety Lock button and start the machine by depressing either the left or right switch levers.

When you're ready to move forward, lower the machine head and pad to the floor and proceed forward in a straight line, at a steady pace.

## **MAINTENANCE**

**AFTER EACH USE:** Store the machine in a clean dry area. Wipe the entire machine and cord down with a clean cloth. Remove the pad and clean thoroughly. Wrap the machine's electrical cord onto the handles and the cord hook provided. **CHECK** the cord and plug for nicks, cuts or damage. Report these to your supervisor for correction.

**WARNING!** Always disconnect the machine's electrical plug from the electrical outlet before performing any service, maintenance, pad changing or inspection of the machine.

**MOTOR:** The motor is lubricated for life under normal use. No oiling or greasing is necessary. However, if the machine is used in dusty areas the motor should be cleaned. Blowing the motor out with compressed air or with the exhaust from a vacuum is suggested. Keeping the motor clean will allow the clear passage of air for ventilation and prevent overheating.

**BELT TENSION:** Proper belt tension is important for smooth operation and belt life. Check the belt tension and have no more than a 1/8-inch deflection. If adjustment is needed, loosen the four (4) motor mounting bolts. Then move the motor and retighten the four (4) motor mounting bolts.

**CARBON BRUSH INSPECTION:** Long life 3000-hour carbon brushes are installed in the motor. The machine is also equipped with a carbon brush wear indicator light to signal when a carbon brush change is required.

# B-1500 BURNISHER, ABS BASE

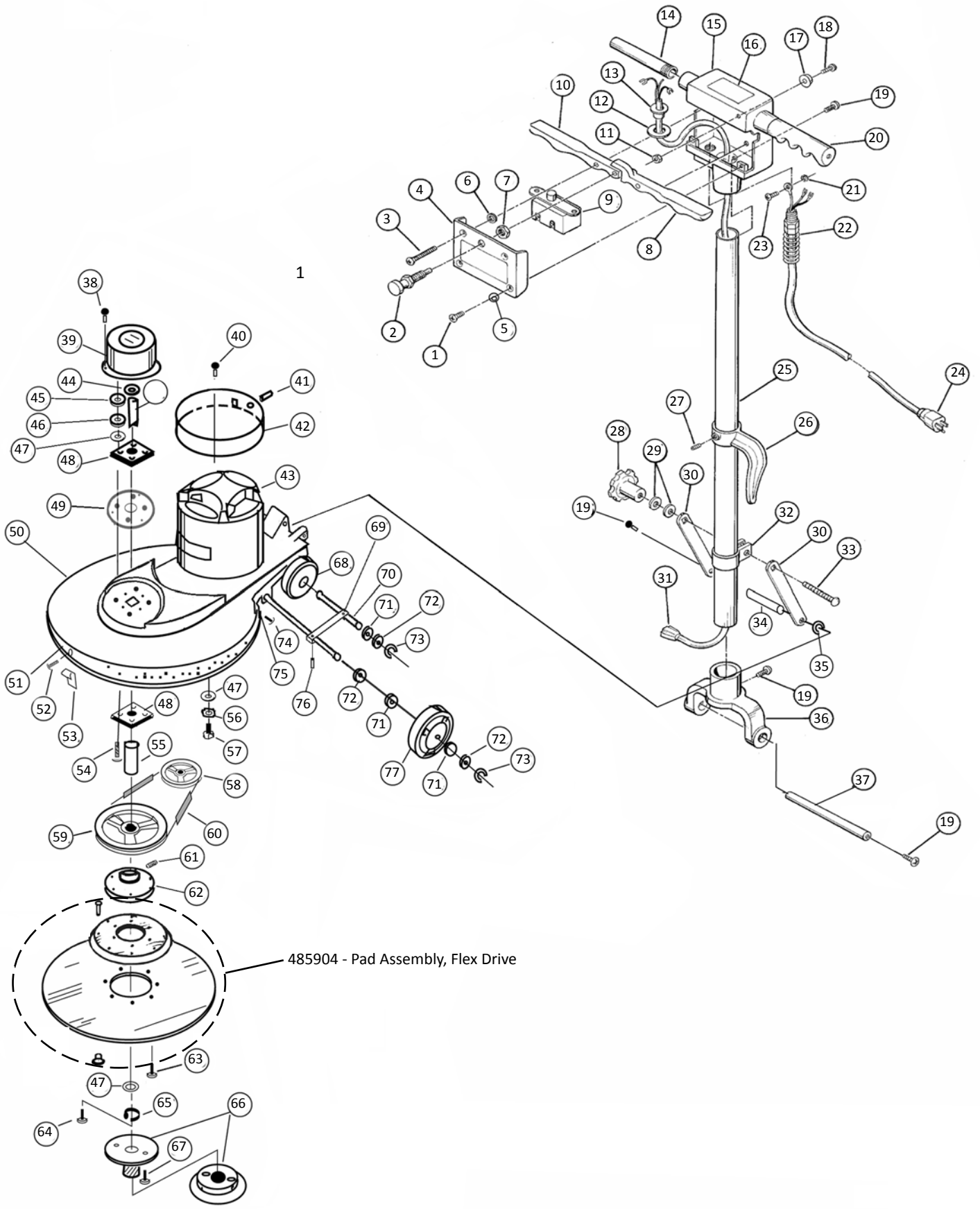

ITEM	PART NO.	DESCRIPTION	QTY.
1	962002	Screw, 10-32 x 1/2 Oval	2
2	504810	Interlock Assembly	1
3	962011	Screw, 10-32 x 1 3/4 Oval	2
4	486407C	Cover, Switch Box	1
5	980018	Washer, #10 C-Sunk External	1
6	509821	Washer, Rubber	2
7	920005	Nut, 3/8-24 Hex Jam	1
8	505121	Lever, Switch Left	1
9	485002	Switch Kit	1
10	505120	Lever, Switch Right	1
11	920001	Nut, 10-32 Nyloc Stop	1
12	509830	Washer, Handle Tube	1
13	503320	Flange, Strain Relief	1
14	505720	Nipple, Handle	2
15	481310C	Switch Box	1
16	515150	Label, Warning	1
17	501210	Bumper, Handle	1
18	962003	Screw, 10-32 x 3/4 PHP	1
19	962006	Screw, 1/4-20 x 1/2 PHP SS	7
20	503711	Grip, Handle, Gray	2
	501501	Cap, Protective End	2
21	980015	Washer, #10 External Tooth	2
22	508520	Strain Relief, Complete	1
	502020	Clamp, Strain Relief	1
23	962015	Screw, 10-32 x 3/8 PHP	2
24	502422	Cord Assembly, 50'	1
25	509082	Tube, Handle	1
26	504420	Hook, Cord	1
27	962005	Screw, 1/4-20 x 3/8 Set	1
28	505010	Knob, Turn	1
29	980007	Washer, 5/16 Flat	2
30	500880	Brace, Handle	2
31	908008	Handle Cord Assembly	1
32	502021	Clamp, Handle	1
33	962009	Bolt, 5/16-18 x 2 1/2 Carriage	1
34	507481	Rod, Brace	1
35	507310	Ring, 3/8 Snap	1
36	509920C	Yoke	1
37	507480	Rod, Yoke	1
38	962161	Screw, 10 x 3/4 PHP HILO	3
39	502319	Cover, Bearing	1
40	962026	Screw, 8-32 x 1/2 Type F	3
41	505181	Light, Brush Wear Indicator 115V	1
	505182	Light, Brush Wear Indicator 220V	1

ITEM	PART NO.	DESCRIPTION	QTY.
42	502396	Cover, Motor	1
43	See Pg. 7	Motor, 1.5HP DC	1
44	502481	Collar, Upper Shaft	1
45	920002	Nut, 3/8-16 Hex	4
46	980009	Washer, 3/8 Lock	4
47	980003	Washer, 3/8 Flat	9
48	501380	Bearing, Block	2
49	486602	Plate, Stiffener	1
50	483214	Base, B-1500, ABS	1
51	501286	Bumper, Base, 48" Gray	1
52	962162	Screw, #10 x 1/2 FHP HILO Zinc	3
53	502110	Clip, Bumper	3
54	962018	Screw, 3/8-16 x 2 HH Zinc	4
55	915001	Key, 3/16 x 2 7/8L	1
56	980009	Washer, 3/8 Lock	4
57	962048	Screw, 3/8-16 1 1/4 HH	4
58	506980	Pulley, Motor	1
59	506994	Pulley, Pad	1
60	903005	Belt, 1500 RPM	1
61	962073	Screw, 1/4-20 x 5/8 Soc Set	2
62	503382	Flange, Flex Pad Driver	1
63	962036	Screw, 1/4-20 x 1 FHP	6
64	962014	Screw, 5/16-18 x 3/4	1
65	980006	Washer, 5/16 Lock	1
66	504471	Pad Holder Assembly	1
67	962076	Screw, #8 x 5/8 PHP	3
68	509780	Wheel, 4" Gray Non-Marking	2
69	487202	Retainer, Axle	1
70	507781	Shaft, Wheel	2
71	980005	Washer, Wave	8
72	509820	Washer, Fiber	12
73	507320	Ring, Snap	4
74	962161	Screw, 10 x 3/4 PHP HILO	2
75	508080	Strap, Bumper, 51"	1
76	962016	Screw, 10-32 x 3/8 Set	1
77	509781	Wheel, 5" Gray Non-Marking	2
<b>Labels Not Shown:</b>			
	485106	Label, Handle Warning	1
	506318	Label, Interlock	1
	506340	Label, Brush Indicator	1

## B-1500 BURNISHER MOTOR PARTS LIST

ITEM	PART NO.	DESCRIPTION	QTY.
	505286	Motor 115V, 1.5HP	1
	505278	Motor 220V, 1.5HP 50C	1
A	502919	End Bell - Motor LOWER	1
B	500417	Armature Asm.w/Bearings,115V	1
	500424	Armature Asm.w/Bearings, 220V	1
	902012	Bearing, Motor Lower	1
C		Field & Shell Assembly	1
D	902003	Bearing, Motor Top	1
E	500903	Carbon Brush, Motor 115V	4
	510901	Carbon Brush, Motor 220V	4
F	507322	Brush Ring Asm. Complete, 115V	1
	507326	Brush Ring Asm. Complete, 220V	1
G		End Bell - Motor TOP	1
I	960018	Bolt, Motor Thru	4
J	911048	Rectifier, 115V	1
	911081	Rectifier, 220V	1
K	908024	Cord Assembly, Motor	1

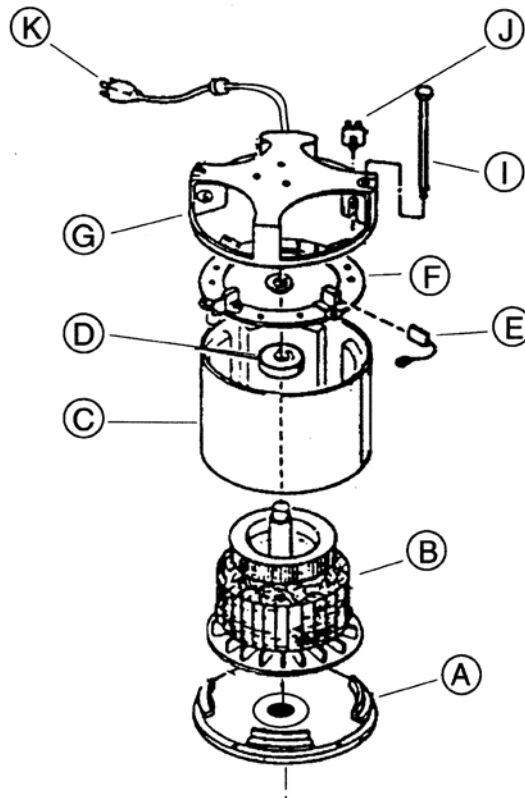

# B-1500 BURNISHER WIRING DIAGRAM

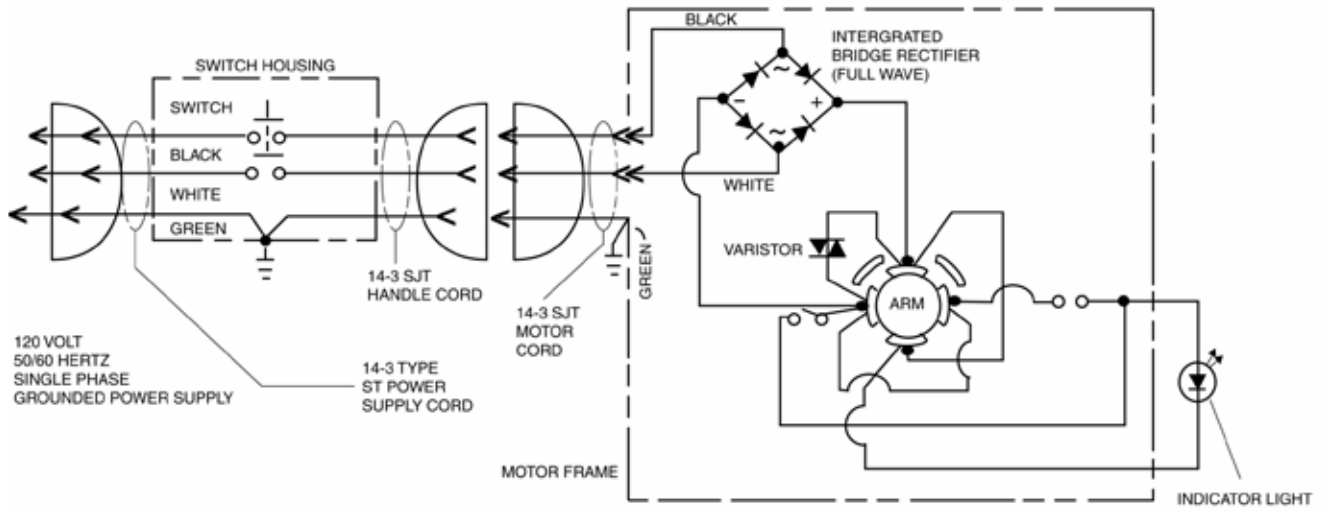

**WARRANTY POLICY**  
**BURNISHER, MODEL B-1500, ABS BASE**

The **Pacific Floorcare B-1500** Burnisher has been manufactured, tested and inspected in accordance with specific engineering requirements and is **WARRANTED** to be free from defects in workmanship and materials as follows:

Eighteen (18) months parts, One (1) year labor - DC Motors (except rectifier and carbon brushes)

One (1) year parts and labor – All other components unless excluded below.

This warranty extends to the original user/purchaser and only when used, operated and maintained in accordance with **Pacific** Operating and Maintenance instructions.

This warranty does not apply to the following wear parts and accessories of the machine including:

<u>Part Number</u>	<u>Part Name</u>
502422	Cord Assembly
509780	Wheel, 4"
509781	Wheel, 5"
503711	Handle Grip, Grey
501286	Bumper Base
903005	Belt
500903	Carbon Brush, 115V Motor

Nor does it apply to damage or failure caused by improper use, abuse or neglect. Warranty credit or replacement of return parts including motors, etc., is subject to incoming inspection of those items.

To secure repair under this warranty, the following procedure should be taken:

- The inoperative machine or warranted parts must be delivered to the authorized dealer with shipping and delivery charges prepaid. If unable to locate the Dealer, you may contact **Pacific** at the address listed herein for the location of the nearest **Pacific** repair center or agent or for other instructions pertaining to your warranty difficulty.
- Upon compliance with the above warranty procedure, all warranted repairs would be completed at no additional charge or cost to the user.
- Only **Pacific** or its authorized dealers and agents may make no charge warranty repairs on this product. All others do so at their own risk.

This warranty limits **Pacific** liability to the repair of the product and/or warranted parts replacement and does not include incidental or consequential damages arising from the use of a **Pacific** machine whether defective or not.

This warranty is in lieu of all other expressed or implied warranties and is extended to the original purchaser/user.



**PACIFIC**<sup>™</sup>  
F L O O R C A R E

**PURPOSE BUILT.**<sup>™</sup>

2259 S. SHERIDAN DRIVE  
MUSKEGON, MICHIGAN 49442-6252  
800-968-1332

FAX 800-863-9536