

BOX EXTRACTORS

DELUXE 15

&

DELUXE 15RH

INTRODUCTION

OPERATING & MAINTENANCE INSTRUCTIONS

READ THIS BOOK

This operator's book has important information for the use and safe operation of this machine. Read this book carefully before starting the machine. Keep this book and tell all operators to read the book. If you do not follow the instructions, you can cause an injury or damage equipment, furniture or buildings.

For new books write to:

Pacific
2259 S. Sheridan
Muskegon, MI 49442-6252

Carefully inspect all components to ensure that there is no concealed freight damage. If such damage is discovered, file a "CONCEALED DAMAGE REPORT" immediately with the delivering carrier.

The contents of this manual are based on the latest product information available at the time of publication. Pacific Steamex reserves the right to make changes or improvements to its machines without notice.

**FOR YOUR CONVENIENCE, RECORD THE MACHINE
MODEL AND SERIAL NUMBER:**

MODEL _____

SERIAL NUMBER _____

PART NUMBER _____

DATE PURCHASED _____

INTRODUCTION

The **Pacific DELUXE 15 Carpet Extractor Machine** is built from highly durable polyethylene and is intended for commercial use. The solution tank holds 15 gallons and the recovery tank holds 13 gallons. A 12-inch, two jet, high pressure wand with 15 feet each of solution and vacuum hoses is provided.

The **DELUXE 15** is designed with a variable pressure pump that can generate up to 250 psi to deep clean carpets without damaging fibers.

The heavy-duty three-stage vacuum motor on the **DELUXE 15** is capable of 137 inches of water lift. This thoroughly extracts the dirty solution from the carpet fibers and reduces the drying time.

DELUXE 15 machines are designed for easy maneuvering by one person. They have large 10" diameter rear wheels and front swivel casters. The machine is 21" wide x 28" long x 35" high and weighs just 80 pounds.

The **DELUXE 15** is built with a hinged tank that provides easy access to internal components for servicing.

Grounding Instructions

This machine must be grounded. If it should malfunction or break down, grounding provides a path of least resistance for electric current to reduce the risk of electric shock. This machine is equipped with a cord having an equipment-grounding conductor and grounding plug. The plug must be inserted into an appropriate outlet that is properly installed and grounded in accordance with all local codes and ordinances.

WARNING - Improper connection of the equipment-grounding conductor can result in a risk of electric shock. Check with a qualified electrician or service person if you are in doubt as to whether the outlet is properly grounded. Do not modify the plug provided with the machine - if it will not fit the outlet, have a proper outlet installed by a qualified electrician.

This machine is for use on a nominal 120-volt circuit, and has a grounded plug that looks like the plug illustrated in figure A. A temporary adapter that looks like the adapter illustrated in figures B and C may be used to connect this plug to a 2-pole receptacle as shown in figure B if a properly grounded outlet (figure A) can be installed by a qualified electrician. The green colored rigid ear, lug, or the like extending from the adapter must be connected to a permanent ground such as a properly grounded outlet box cover. Whenever the adapter is used, it must be held in place by a metal screw.

NOTE: In Canada, the use of a temporary adapter is not permitted by the Canadian Electrical Code

EXTENSION CORDS

Use only three-wire 14/3 or larger gauge approved extension cords that have three-prong grounding type plugs and three-pole receptacles that accept the appliance's plug. Replace or repair any damaged cords or plugs.

When servicing, refer to authorized person only. Use only identical replacement parts.

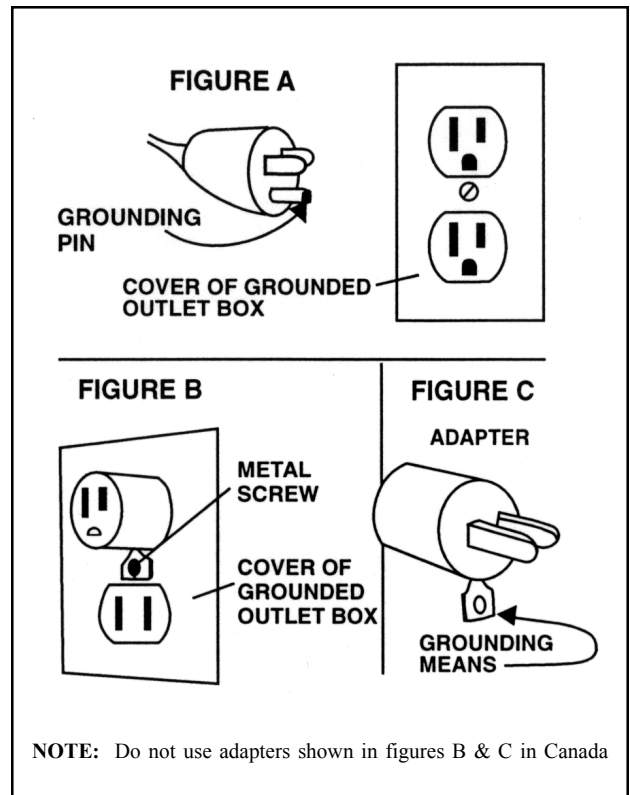

IMPORTANT SAFETY INSTRUCTIONS

When using an electrical appliance, basic precautions should always be followed, including the following:

READ ALL INSTRUCTIONS BEFORE USING THIS MACHINE

WARNING: To reduce the risk of fire, electric shock, or injury:

1. You must have training in the operation of this machine before using it.
2. Always use a separate circuit for the heater (other than the one used by the extractor) before attempting use.
3. Do not operate the heater until the solution system is pressurized with cleaning solution.
4. Always shut the heater off when solution is not circulating through the system.
5. Make sure the pump is continuously running when the heater switch is on.
6. Machines can cause an explosion when near flammable materials and vapors. Do not use this machine with or near fuels, grain dust, solvents, thinners, or other flammable materials.
7. Do not operate this machine unless it is completely assembled.
8. Do not use this unit for dry pick-up of dust or debris. Do not pick up anything that is burning or smoking, such as cigarettes, matches or hot ashes.
9. To prevent electric shock, always remove the electrical plugs from the electrical outlets before doing any repairs or maintenance to this machine.
10. To prevent injury, always remove the electrical plugs from the electrical outlet before leaving the machine.
11. Maintenance and repairs must be done by authorized personnel only.
12. Do not immerse. To reduce the risk of electrical shock, use only on carpet moistened by the cleaning process. Protect the machine from rain. Keep the machine in a dry building. Always clean the machine with a clean dry cloth.
13. Always use a three-wire electrical system connected to the electrical ground. For maximum protection against electrical shock, use a circuit that is protected by a ground fault circuit interrupter. Consult your electrical contractor.
14. To prevent damage to the power cord, do not move this machine over the power cord. Always lift the power cord over the machine. Do not pull or carry cord, use cord as a handle, close a door on cord, or pull cord around sharp edges or corners. Keep cord away from heated surfaces.
15. Make sure all switches are turned off before plugging or unplugging it power cord into/from a wall receptacle.
16. Do not use water that is hotter than 60°C (140°F).
17. To prevent damage to the solution system components do not store in freezing temperatures without proper maintenance.
18. Do not allow to be used as a toy. Close attention is necessary when used near children.
19. Do not use with damaged cord or plug. If the machine is not working as it should, has been dropped, damaged, left outdoors, or dropped into water, return it to a service center.
20. Do not unplug by pulling on cord. To unplug, grasp the plug, not the cord.
21. Do not handle the plug or machine with wet hands.

PREPARATION AND OPERATION

PRESTART-UP CHECKS

DELUXE 15 models are very simple and easy to operate. Very little maintenance and service are required to keep your machine in top operating condition.

The following procedures are recommended to maintain the high level of performance expected from your machine. They are also intended to identify potential safety hazards and problems which could reduce the service life of the machine.

READ BEFORE OPERATING YOUR MACHINE:

1. Check **power cord, plug** and **strain relief** for worn or damaged insulation (for both the machine and heater if applicable). Repair or replace if necessary.
2. Make sure the **drain hose** is plugged and placed in its storage position on the back of the tank.
3. Inspect the **vacuum head** on the wand for any damage. Burrs on the contact surface may snag carpet fibers. Gouges, scratches and chipped areas can reduce vacuum performance.
4. Check the **inlet strainer** for damage or debris. It is located at the bottom of the fresh water (solution) tank. Holes in the screen can allow contaminants to enter the pump resulting in costly repairs. A clogged strainer will reduce pump performance and may cause permanent damage.
5. Unscrew the clear round **plastic cover** on top of the recovery (vacuum) tank.
 - a) Inspect the **cover** and **gasket** for damage. Dirt or debris on the gasket or sealing surface of the tank can cause a vacuum leak and reduce vacuum performance.
 - b) The **float assembly** consists of a **screen** and **ball shut off** to protect the vacuum motor. To remove it twist the assembly from the white vacuum tube. Then clean the screen of debris. It should be checked periodically for any damage and replaced when necessary.

Replace the cover, making sure it is securely in place.

OPERATION

The following procedures are intended to describe and detail proper operation of your machine. Failure to follow these recommended procedures can reduce the machine's performance and may result in damage to the machine.

1. **Vacuum the area to be cleaned.** Your machine will do a more thorough job if the loose dirt and debris are removed before the extraction process begins.
2. **Fill the fresh water tank** (lower tank) with up to 15 gallons of hot water and cleaning chemical. Do not use water hotter than 60°C (140°F). Mix in chemicals according to the chemical manufacturer's recommendations. Powdered chemical must be premixed with water before pouring into the solution tank.
3. Use of an extension cord is not recommended. However, if one is necessary, use only a 14 gauge or larger cord. Smaller or inferior cords are dangerous and may cause damage to your machine.
4. **Connect the wand assembly and hoses to the machine.** The 3/8-inch solution hose simply inserts into the quick connect located on the front of the machine. The vacuum hose slides over the tube located on the front of the recovery (upper) tank.
5. If the machine is equipped with a heater, the **power cords must be plugged into two separate 20 amp grounded outlets of the correct voltage.** See Grounding Instructions.
6. The **control panel** is located on top of the recovery tank, near the handle and contains the following:
 - a) **The pump switch should be turned on first.** The solution pump is self-priming and completely fills the system. A priming valve is located in the solution fill opening to aid in priming.
 - b) **The solution pressure is adjustable with the knob located on the front of the machine** (next to the solution hose outlet). You can adjust the pressure up to 250 psi; taking under consideration the condition of the carpet (i.e. the type and how dirty it is).

OPERATION

- c) Turn on the **heater** if hotter solution is desired. **NOTE: The pump must be ON when the heater is ON.**
- d) **Turn ON the vacuum switch.** You may now begin the cleaning process.
7. Depressing the **valve trigger** on the wand will allow the solution water to flow.
8. Foaming may occur as dirty solution is recovered. Excessive foaming can be counteracted with liquid defoamer (follow the chemical manufacturers directions). **Do not allow foam to rise into or near the float assembly in the recovery tank.** Use defoamer or empty and flush the recovery tank.
9. When finished cleaning, **turn off the heater, vacuum and pump switches.**
10. Always **drain the recovery tank** after each use; simply pull the plug from the tote hose on the back of the tank and drain. Dispose of the recovered water properly.
11. To **drain the solution tank**, attach the optional drain or “pump out” hose (part number 204172) to the accessory quick connect on the front of the machine. Place the open end of the hose into a bucket and turn on the pump switch. When empty, turn off the pump switch and remove the hose from the quick connect.
12. **All switches should now be OFF**, unplug the power cord(s) from the electrical outlet before doing any clean-up.
13. **After each use clean the cover, float assembly and gasket.** Do not reinstall the cover until the next use, this will allow the recovery tank to dry out.

SERVICING

The DELUXE 15 extractors are designed and manufactured to provide years of trouble free service with a minimum of maintenance and service. The following recommendations are intended to assist the operator and Service Technician in performing routine maintenance.

Failure to follow these recommendations can result in damage to your machine and diminished performance.

Warning: Always unplug your machine before performing any service. Severe personal injury could result if the electrical power is not disconnected.

1. **Always follow through with the recommended prestart-up checks** found in the Preparation and Operation section of this manual.
2. **Store your machine in a dry, protected area.** Do not expose this machine to rain, standing water or freezing temperatures.
3. **We recommend a good, thorough cleaning after each use.**
 - a) Clean the cover, float assembly and gasket.
 - b) Clean out the recovery tank with fresh water making sure all deposits or debris are removed.
 - c) Check and clean the inlet strainer in the solution tank periodically with clean water. Make sure the strainer is properly in place to protect the pump.
 - d) Wipe the machine down with a damp cloth.
4. **The jet tips and strainer/check valves on the wand will need cleaning after repeated use.** First remove the jet caps, then the jet tips and strainer/check valves. Soak them in vinegar until visible deposits are dissolved, then scrub with a soft bristle brush. Reassemble.

Jet tips and strainer/check valves should be replaced once a year because they tend to erode under extended use.
5. **AN AUTHORIZED SERVICE CENTER SHOULD PERFORM SERVICE TO THE PUMP AND VACUUM MOTOR.** The tank is hinged to provide easy access to the internal components.

Additional service information is available from your local Pacific Distributor or through our Technical Service Department.

DELUXE 15

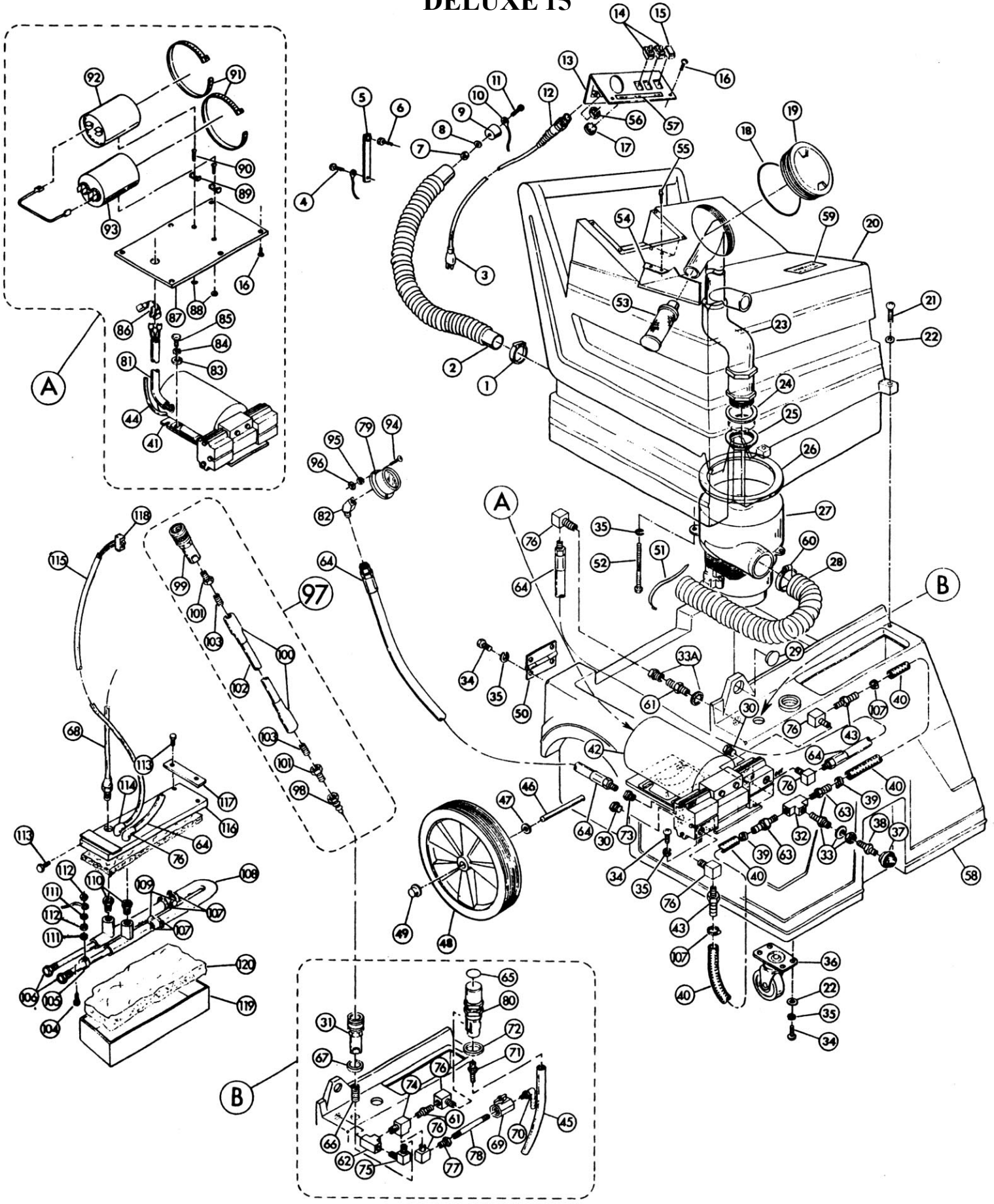

DELUXE 15 PARTS LIST

ITEM	PART NO.	DESCRIPTION	QTY.
1	602012	Clamp Hose	1
2	604107	Hose, Drain PolyVac	1
3	S266P1	Cord, 25 feet black	1
4	962015	Screw, 10-32 x 3/8	1
5	608508	Strap	1
6	603313	Fastener	1
7	920017	Nut, 10-24 ESNA	1
8	W107D	Washer, 3/16 Flat	1
9	608504	Stopper, Drain	1
10	602408	Cord, Stopper Stretch	1
11	962113	Screw, 10-24 x 1-1/4 PHP	1
12	A13020	Strain Relief	1
13	227072	Panel, Control	1
14	911089	Switch, Rocker	2
15	S519PB	Switch, Blank	1
16	W351D	Screw, 10-24 x 1/2 THP	10
17	S799NP1	Plug	1
18	223403	Gasket Cover	1
19	222302	Cover, Cleanout	1
20	228673	Tank Vacuum, 15 Gallon	1
21	962117	Screw, 1/4-20 x 1-1/2	2
21	W104D	Washer, 1/4 Flat	8
23	228571	Standpipe Assembly	1
24	S400P6	O-Ring	1
25	A13012	Sealing Nut, 1-1/4	1
26	S446P1	Gasket, Blower Ring 3/8 Thick	1
27	A13504	Vac. Motor, 3 Stage 115V	1
	3738	Vac. Motor, 3 Stage 230V	1
	210901	Carbon Brush	2
28	224160	Hose, 2 inch	1.4 ft.
29	221373	Plug Button	1
30	S804N	Plug, 3/8 Brass HH	2
31	203308	Quick Connect, 1/4 Female	1
32	203356	Brass Tee, 1/4	1
33	T4056	Coupling, 1/4 with Nut & Washer	1
33A	T4056	Coupling, 1/4 with Washer Only	1
34	962006	Screw, 1/4-20 x 1/2 PHP	20
35	980002	Washer, 1/4 Lock	27
36	S130P	Caster	2
37	S626P	Strainer, 3/8 NPT	1
38	S479P	Brass Reducer, 3/8 x 1/4 MPT	1
39	223341	Clamp, 3/4 Crimp	2

ITEM	PART NO.	DESCRIPTION	QTY.
40	224173	Hose, 1/2 ID Braided	2 ft.
41	226670	Plate, Pump Mounting	1
42	227073	Pump & Motor, 115 V	1
43	T4012A	Brass: Barb 1/2 to 3/8 MPT	2
44	908066	Cord Assembly, 18-3 x 4 ft.	1
45	S250P	Hose, 3/8 Push Lock	1 ft.
46	227770	Shaft, Wheel	1
47	W120D	Washer, 7/16 Flat	2
48	229750	Wheel, 10 x 1.75 Grey	2
49	S482P	Snap Axle Cap, 1/2	2
50	204552	Hinge, Vac Tank	2
51	911104	Tie, Cable 14.5 Lg.	1
52	W196D	Screw, 1/4-20 x 4 HH	3
53	223370	Float Assembly	1
54	221371	Baffle	1
55	930006	Pop Rivet, 1/8 x 1/2	2
56	920616	Nut, 1/2 NPT	1
57	225173	Label, Switch	1
58	228672	Solution Tank, Grey	1
59	D161C	Decal, Add Defoamer	1
60	S216P	Clamp, Hose Blower Assembly	1
61	S222N	Brass: Hex Nipple, 1/4	2
62	S904A	Brass: Union Tee 1/4	1
63	203315	Fitting, 1/4 MPT x 1/2 Barb	2
64	224171	Hose, Pulse	1
65	225179	Label, Pressure	1
66	205752	Nipple, Close 1/4 NPT	2
67	S124R	Grip, Black 7/8 ID	0.019 ft.
68	224172	Hose, Pulse 17 inches	1
69	3824	Ball Valve, Directional	1
70	3770	Elbow, Male 1/8	1
71	203359	Fitting, Hose Barb 3/8	1
72	223470	Gasket, Regulator Seal	1
73	S342P1	Brass Bushing, 1/4 FIPT x 3/8	1
74	T4004R	Brass Street Tee, 1/4 FIPT	1
75	T4023	Brass, 90 St. Elbow, 3/8	3
76	T4027	Brass, 90 St. Elbow, 1/4 FIPXM	5
77	S342P	Brass Bushing, 1/8 FIPT x 1/4	1
78	225770	Nipple Long, 1/8 MPT x 3	1
79	223870	Gauge, 400 PSI	1
80	227570	Regulator	1
81	3716	Wire Jacket	2 ft.

CONTINUED ON NEXT PAGE

DELUXE 15 PARTS LIST

ITEM	PART NO.	DESCRIPTION	QTY.
82	T4055	Elbow, 1/4 x 45 Deg. St.	1
83	980007	Washer, 5/16 Flat	4
84	980006	Washer, 5/16 Lock	4
85	W506D	Screw, 5/16-18 x 3/4 HH	4
86	508519	Strain Relief	1
87	226672	Plate, Capacitor Mounting	1
88	W440D	Nut, 8-32 Hex w/ Nyloc	2
89	225670	Noun, Cable Tie	2
90	W205D	Screw, 8-32 x 1 PHS	2
91	A13066	Wire Ties	2
92	911206	Start Capacitor	1
93	911205	Run Capacitor	1

ITEM	PART NO.	DESCRIPTION	QTY.
94	W324D	Screw, 6-32 x 1/2 RHP	3
95	980033	Washer, #6 Flat SS	3
96	W144D	Nut, 6-32 Hex	3
	F215W	Vac. Hose Assembly, 15 ft. (Not Shown)	1
97	F462W	HP Hose Assembly, Solution, 15 ft.	1
98	203302	Quick Connect, 1/4 Male	1
99	203308	Quick Connect, 1/4 Female	1
100	217501	Relief, Pressure Hose Strain	2
101	223350	Fitting, 1/4 x 1/4 MP SW Barb	2
102	3681	Hose, 1/4 High Pressure	15 ft.
103	S226P	Ferrule	2

HEATER

104	W324D	Screw, 6-32 x 1/2 RHP MS S/S	1
105	228572	Strap, Ground	1
106	224570	Heater Element	2
107	222070	Clamp	8
108	222270	Coil, Heater	1
109	228570	Sensor, Heater	2
110	S342P1	Brass Bushing, 1/4 FIPT x 3/8	2
111	980016	Washer, 5/16 Lock	2
112	920016	Nut, 6-32 Hex	2

113	962119	Screw, 8 x 1/2 HH	7
114	508519	Strain Relief	1
115	908068	Cord Assembly, 14-3 x 52 inches	1
116	222370	Cover, Heater	1
117	228573	Support, Heater	2
118	911089	Switch, Rocker SPST 20 Amp	1
119	221370	Box, Heater	1
120	229870	Wrap, Fiber Glass	1
	S266P1	Cord, 25 feet, Black	1

Optional Service Parts for Pump

PART NO.	DESCRIPTION
225072	Cam & Bearing Assembly
225073	Valve & O-Ring Kit
225074	Plunger, Guide & Seal Kit

DELUXE 15 WIRING DIAGRAM

Machine

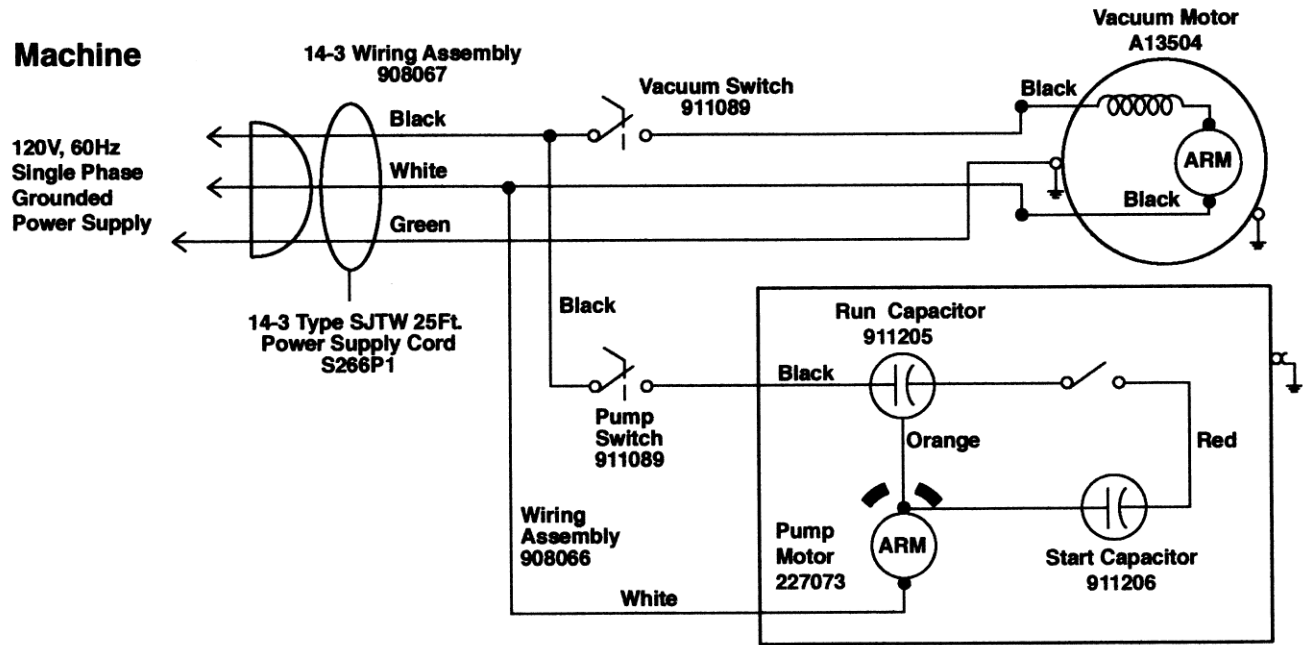

Optional Heater

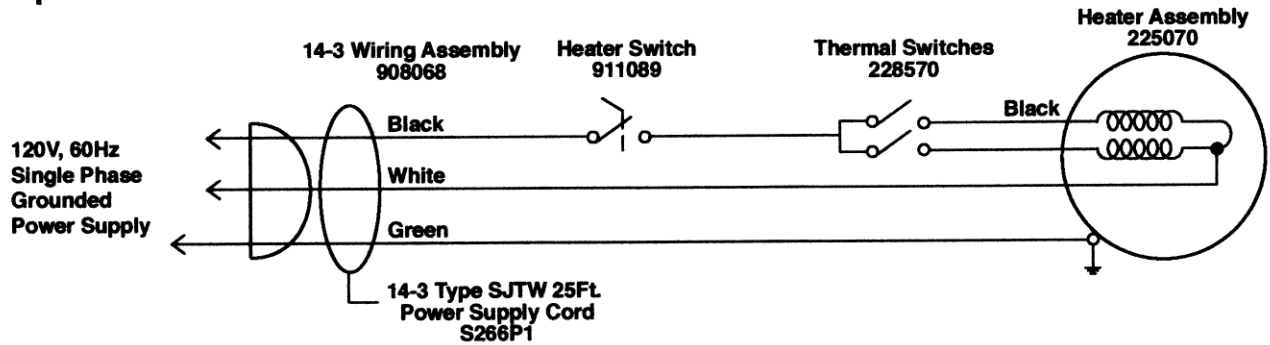

2 JET WAND

219801 HP

12 INCH SS

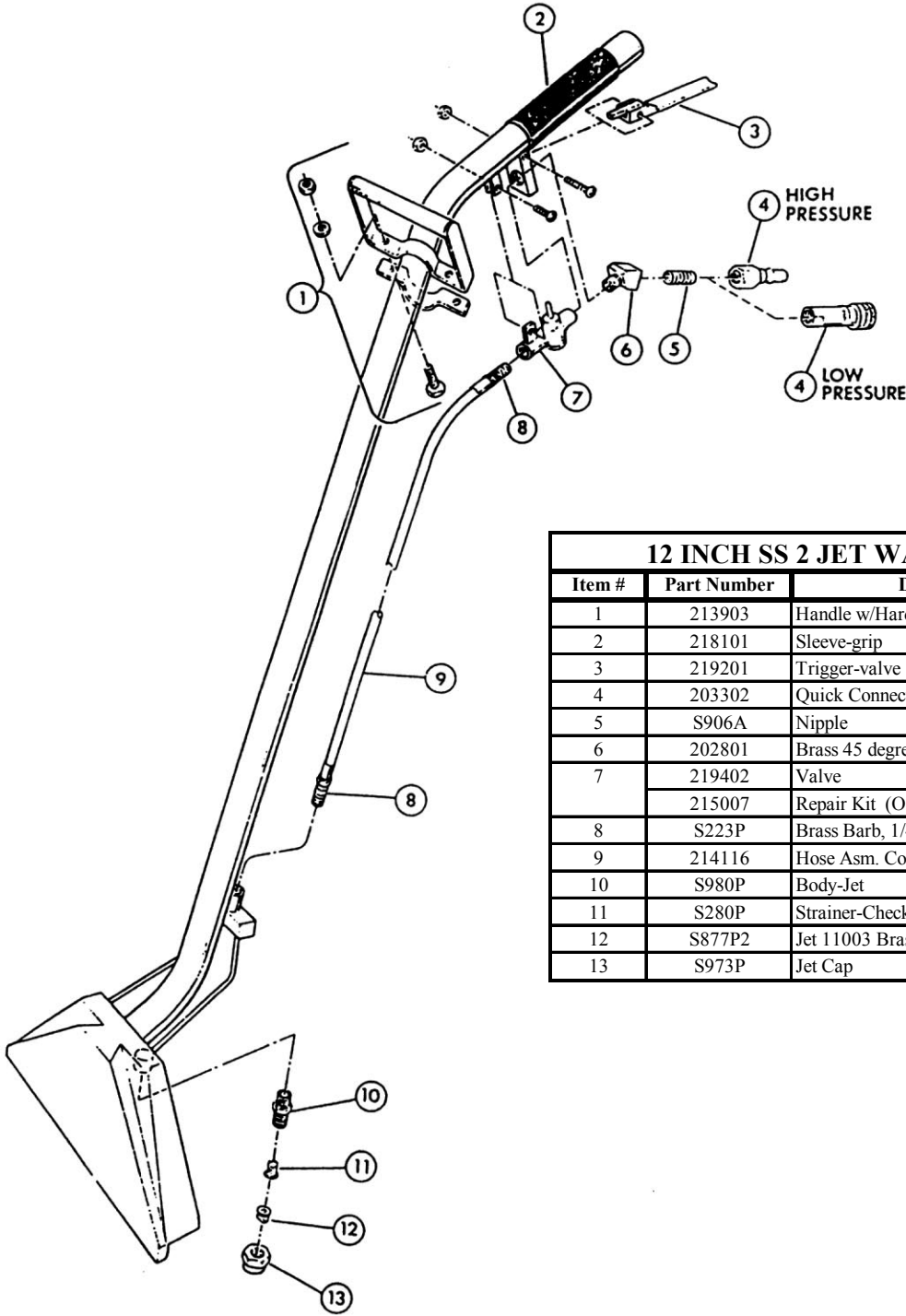

12 INCH SS 2 JET WAND - 219801 HP			
Item #	Part Number	Description	Quantity
1	213903	Handle w/Hardware	1
2	218101	Sleeve-grip	1
3	219201	Trigger-valve	1
4	203302	Quick Connect-1/4"male(HP)	1
5	S906A	Nipple	1
6	202801	Brass 45 degree Street Elbow	1
7	219402	Valve	1
8	215007	Repair Kit (O-ring, spring, disk)	1
8	S223P	Brass Barb, 1/4"	2
9	214116	Hose Asm. Complete	1
10	S980P	Body-Jet	2
11	S280P	Strainer-Check Valve	2
12	S877P2	Jet 11003 Brass	2
13	S973P	Jet Cap	2

NOTES

WARRANTY POLICY DELUXE 15 CARPET EXTRACTOR

The **Pacific** Deluxe 15 Carpet Extractor has been manufactured, tested and inspected in accordance with specific engineering requirements and is **WARRANTED** to be free from defects in workmanship and materials as follows:

Five (5) years parts, One (1) year labor – Polyethylene components.
One (1) year parts & labor – All other components unless excluded below.

This warranty extends to the original user/purchaser and only when used, operated and maintained in accordance with **Pacific** Operating and Maintenance instructions.

This warranty does not apply to the following wear parts and accessories of the machine including:

Part Number	Part Name
S266P1	Cord Assembly
229750	Wheel
S130P	Caster
S626P	Strainer
210901	Carbon Brush
S280P	Strainer, Check Valve
S877P2	Jet

Nor does it apply to damage or failure caused by improper use, abuse or neglect. Warranty credit or replacement of return parts including motors, pumps, etc., is subject to incoming inspection of those items.

To secure repair under this warranty, the following procedure should be taken:

- The inoperative machine or warranted parts must be delivered to the authorized dealer with shipping and delivery charges prepaid. If unable to locate the Dealer, you may contact **Pacific** at the address listed herein for the location of the nearest **Pacific** repair center or agent or for other instructions pertaining to your warranty difficulty.
- Upon compliance with the above warranty procedure, all warranted repairs would be completed at no additional charge or cost to the user.
- Only **Pacific** or its authorized dealers and agents may make no charge warranty repairs on this product. All others do so at their own risk.

This warranty limits **Pacific** liability to the repair of the product and/or warranted parts replacement and does not include incidental or consequential damages arising from the use of a **Pacific** machine whether defective or not.

This warranty is in lieu of all other expressed or implied warranties and is extended to the original purchaser/user.



PACIFIC

2259 Sheridan
Muskegon, Michigan 49442
Ph: (800) 968-1332 Fax: (231) 773-1642

www.nextwaveofclean.com