

# FLOORMASTER 18B

## INTRODUCTION

## OPERATING & MAINTENANCE INSTRUCTIONS

### READ THIS BOOK

This operator's book has important information for the use and safe operation of this machine. **Read this book carefully before starting the machine.** Keep this book and tell all operators to read the book. If you do not follow the instructions, you can cause an injury or damage equipment, furniture or buildings.

For new books write to:

*Pacific*

2259 S. Sheridan

Muskegon, MI 49442-6252

Carefully inspect all components to ensure that there is no concealed freight damage. If such damage is discovered, file a "CONCEALED DAMAGE REPORT" immediately with the delivering carrier.

The contents of this manual are based on the latest product information available at the time of publication. Pacific Steamex reserves the right to make changes or improvements to its machines without notice.

### FOR YOUR CONVENIENCE, RECORD THE FOLLOWING IMPORTANT INFORMATION:

MODEL \_\_\_\_\_

SERIAL NUMBER \_\_\_\_\_

PART NUMBER \_\_\_\_\_

DATE PURCHASED \_\_\_\_\_

**TABLE OF CONTENTS**

**IMPORTANT SAFETY INSTRUCTIONS . . . . . 3**

**SYMBOLS USED ON THE MACHINE . . . . . 4**

**MACHINE PREPARATION . . . . . 6**

    1. UNPACKING THE MACHINE . . . . . 6

    2. BATTERY INSTALLATION . . . . . 6

    3. CONNECTING THE BATTERY CHARGER . . . . . 7

    4. CHARGING THE BATTERIES . . . . . 7

    5. CONNECTING THE BATTERY CONNECTOR . . . . . 8

    6. BATTERY INDICATOR . . . . . 8

    7. SQUEEGEE ASSEMBLY . . . . . 8

    8. ADJUSTING THE SQUEEGEE HEIGHT . . . . . 9

    9. ADJUSTING THE SQUEEGEE INCLINATION . . . . . 9

    10. HEIGHT HANDLE BAR . . . . . 9

    11. RECOVERY TANK . . . . . 9

    12. SOLUTION TANK . . . . . 10

    13. SOLUTION WATER . . . . . 10

    14. ADJUSTING THE BRUSHES . . . . . 10

**OPERATION . . . . . 11**

    OPERATING . . . . . 11

    DEVICE TOO FULL . . . . . 12

    MOVEMENT . . . . . 12

    BRAKE . . . . . 12

**UPON COMPLETION OF THE WORK . . . . . 13**

**DAILY MAINTENANCE . . . . . 14**

    CLEANING THE RECOVERY TANK . . . . . 14

    CLEANING THE SOLUTION TANK FILTER . . . . . 15

    CLEANING THE VACUUM FILTER . . . . . 15

    CLEANING THE SQUEEGEE . . . . . 15

    REPLACING THE SQUEEGEE BLADES . . . . . 15

    DISASSEMBLY OF THE BRUSH . . . . . 16

**WEEKLY MAINTENANCE . . . . . 17**

    CLEANING THE SQUEEGEE HOSE . . . . . 17

    CHECK BRAKE . . . . . 17

**TROUBLE SHOOTING GUIDE . . . . . 18**

    INSUFFICIENT WATER ONTO THE BRUSH . . . . . 18

    THE MACHINE DOES NOT CLEAN SATISFACTORILY . . . . . 18

    THE SQUEEGEE DOES NOT DRY THE FLOOR WELL . . . . . 18

    EXCESSIVE FOAM PRODUCTION . . . . . 18

**WARRANTY POLICY . . . . . 20**

## IMPORTANT SAFETY INSTRUCTIONS

**READ AND UNDERSTAND ALL INSTRUCTIONS AND WARNINGS BEFORE OPERATING THIS MACHINE!**



**WARNING: To reduce the risk of fire, electric shock or injury:**

1. You must have training in the operation of the machine before using it. **READ THE INSTRUCTION BOOK.** If you do not understand any instruction, ask your supervisor.
2. Make sure all labels, decals, warnings, cautions and instructions are fastened to the machine.
3. Read the labels carefully on the machine. Do not cover them for any reason and replace them if damaged.
4. Do not operate this machine unless it is completely assembled, inspect the machine carefully before operation.
5. Pay close attention to other people and especially children while operating this machine.
6. Be a careful driver, do not strike shelving or scaffolding, especially where there is a danger of falling objects.
7. Machines can cause an explosion when operated near flammable materials and vapors. Do not use this machine with or near fuels, grain dust, solvents, thinners, or other flammable materials.
8. In case of fire, use a powder extinguisher. Do not use water.
9. Do not use this machine as a means of transport.
10. Do not use acid solutions that could damage the machine.
11. Adjust your speed to the conditions of the floor.
12. Do not turn the machine on a ramp. Do not stop and leave the machine on a ramp or incline.
13. When the machine is parked, take out the key and set the parking brake.
14. During any maintenance operation disconnect the power supply from the machine.
15. Lead acid batteries generate gases that can cause an explosion. Read the instruction manual supplied with the battery charger. Keep sparks and flames away from batteries.  
**NO SMOKING.** Charge the batteries only in an area with good ventilation.
16. Do not use a charger if the power cord is damaged.
17. Always wear eye protection and protective clothing when working near batteries. Remove all jewelry. Do not put tools or other metal across the battery terminals, or the tops of the batteries.
18. Check the level of the electrolyte every time you charge the batteries. If the level is low, add distilled water only.
19. Maintenance and repairs must be performed by authorized Service Centers only. Make adjustments according to the specifications given in the service manual for this machine.
20. Keep the electrical parts of the machine dry. Do not wash the machine with direct water jets or high pressure, nor with corrosive material. For storage, keep the machine in a dry building.
21. Water solutions or cleaning materials used with this type of machine can leave wet areas on the floor surface. These areas can cause a dangerous condition for the operator or other persons. Always put CAUTION signs near the area you are cleaning.
22. Do not reach under shrouds with fingers, hands, or toes when machine is running.

## SYMBOLS USED ON THE MACHINE

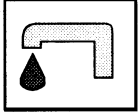

Symbol for the **water valve**:  
Indicates the solenoid valve switch.

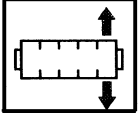

Symbol indicating the raised or lowered position of the **brush base**:  
Indicates the lever for lifting the brush base.

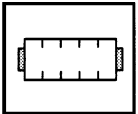

Symbol for the **brush**:  
Indicates the brush motor switch.

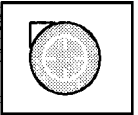

Symbol for the **vacuum motor**:  
Indicates the vacuum motor switch.

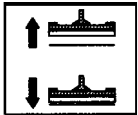

Symbol indicating the raised or lowered position of the **squeegee**:  
Indicates the squeegee lever position.

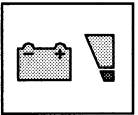

Symbol indicating the charge levels of the **batteries**:  
It is necessary to recharge the batteries when the green light begins to blink



Symbol for the **brakes**:  
It is used on top of the emergency and parking brake lever.

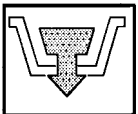

Indicates the **drain pipe** of the recovery tank.

## SYMBOLS USED ON THE MACHINE



Indication of the maximum recommended temperature for the solution water (50°C or 122°F): It is located near the fill hole of the solution tank.

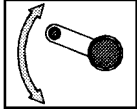

Symbol indicating the adjustment lever for the **handle bar height**.

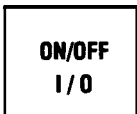

Symbol for the **key switch**.



Symbol for the **coupling**:  
Indicates the anchor points and the load direction.

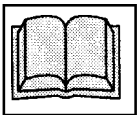

This symbol serves as a reminder for the operator to read the **manual**.



The **WARNING** symbol:  
Carefully read the sections preceded by this symbol, this is for the safety of the operator and of the machine.

# MACHINE PREPARATION

## 1. UNPACKING THE MACHINE

1. Use a fork truck to move the machine when packaged.
2. Take off the outer package
3. The machine is fixed on the pallet with wooden wedges that block the wheels.
4. Take the wedges off.

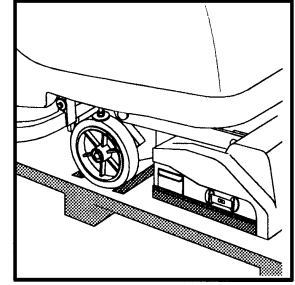

5. Using a ramp, pull the machine down from the pallet, pushing it in reverse motion. Avoid violent blows to the base.

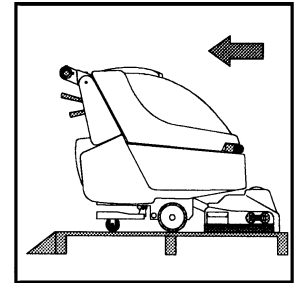

## 2. BATTERY INSTALLATION

The two 12 volt 145 A/H batteries fit in the compartment under the recovery tank.

Recommended Batteries: Crown Battery Manufacturing Company Part #711

Trojan Battery Company Part #30XHS

East Penn Manufacturing Company Part #8KFS



For battery maintenance and charging, follow the instructions provided by the battery supplier.

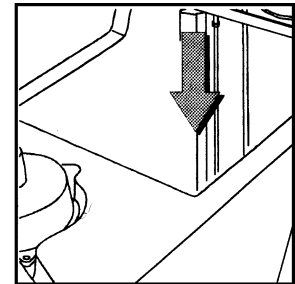

### Installation Instructions:

1. Lift the recovery tank forward.
2. Detach the squeegee hose (1) from the recovery tank.
3. Take off the vacuum plug (2) by rotating it counterclockwise.
4. Take the recovery tank off.
5. Place the batteries in their compartment.

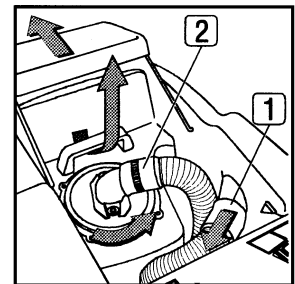

## MACHINE PREPARATION

6. Connect the batteries' connector (2) to the machine's connector (1).
7. Reassemble the recovery tank, vacuum plug and squeegee hose.

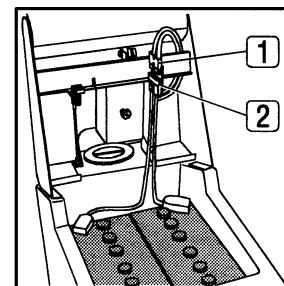

### 3. CONNECTING THE BATTERY CHARGER

The battery charger's connector fits into the battery connector (2) located under the recovery tank.

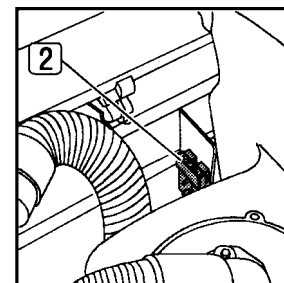

### 4. CHARGING THE BATTERIES

**NEVER ALLOW THE BATTERIES TO RUN COMPLETELY DOWN**, recharge them within a few minutes after the battery indicator starts blinking. **Never leave the batteries completely discharged**, even if the machine is not being used.

Check the electrolyte level at least every 20 times the batteries are charged. **Add only distilled water** if the level is low.

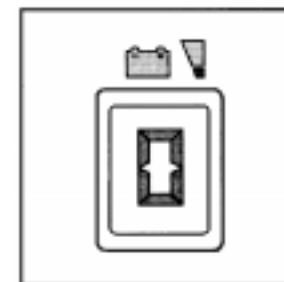

**WARNING!** When charging the batteries, follow all the instructions provided with this manual and the battery charger. Trained staff must carry out the installation and maintenance operations.

**WARNING! Fire Danger:** Lead acid batteries generate gases that can cause an explosion. Keep sparks and flames away from batteries. **NO SMOKING!**

**WARNING!** To prevent an explosion, charge the batteries only in an area with good ventilation.

**WARNING!** Always wear eye protection and protective clothing when working near batteries.

When charging the batteries, keep the recovery tank lifted with the prop as shown in the figure.

Turn the key to the OFF position. Connect the DC connector on the charger to the DC battery connector. Connect the AC charger plug to a receptacle that has the correct voltage and frequency for your charger. Make sure the receptacle is connected to the electrical ground.

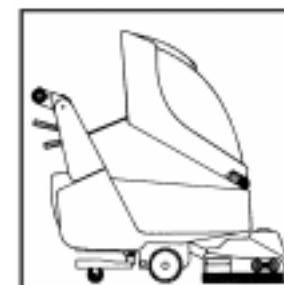

## MACHINE PREPARATION

### 5. CONNECTING THE BATTERY CONNECTOR

After charging the batteries, reconnect the battery connector (2) to the connector of the machine (1).

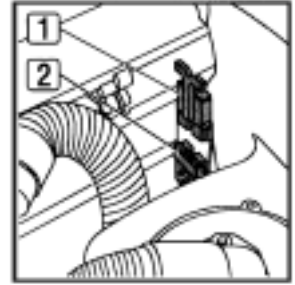

### 6. BATTERY INDICATOR

The battery indicator is a green signal light; it is constantly on when the batteries are sufficiently charged. The signal light will blink when it is necessary to recharge the batteries.

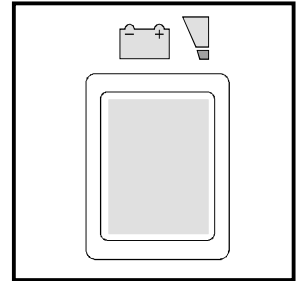

### 7. SQUEEGEE ASSEMBLY

The squeegee is assembled as shown in the figure. The squeegee lever should be in its up position. Insert the holding pin into the squeegee stud bolt to secure the squeegee in place. Then fit the squeegee hose into its coupling; the hose should be located to the right of the lifting cable.

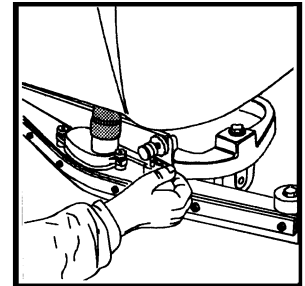



## MACHINE PREPARATION

### 8. ADJUSTING THE SQUEEGEE HEIGHT

The height from the floor to the squeegee should be adjusted based on the blade's wear. Rotate the knob (2) counter-clockwise to lift the squeegee and clockwise to lower it.

**Note:** Adjust the right and left knobs the same amount; the squeegee should be positioned parallel to the floor.

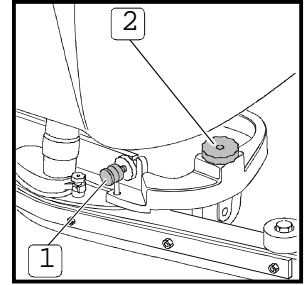

### 9. ADJUSTING THE SQUEEGEE INCLINATION

During operation, the rear squeegee blade is most efficient when tilted back about 3/16 inch (5mm) along its whole length. To increase the blade bending in the central part, tilt the squeegee body backward by turning the adjuster (1) counter-clockwise. Subsequently, turn the adjuster clockwise to increase the bending at the sides of the squeegee blade.

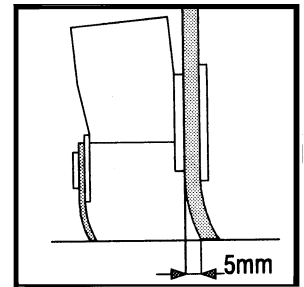

### 10. HANDLE BAR HEIGHT

The handle bar is adjustable in three different positions:

1. Release the lever.
2. Put the handle bar at the desired height.
3. Release the lever and the handle bar will lock in place.

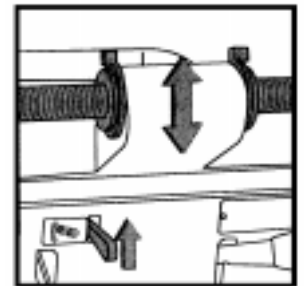

### 11. RECOVERY TANK

1. Open the cover and confirm the vacuum plug (2) is properly closed: line up the notches and rotate the plug clockwise to close. The vacuum motor hose must also be attached.
2. Confirm the squeegee hose (1) is properly connected.
3. Make sure the drain plug, which is located in the front of the machine is also closed.

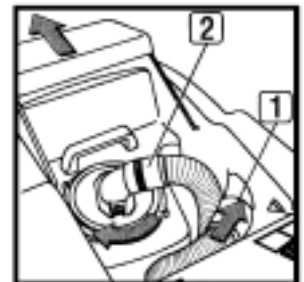

## MACHINE PREPARATION

### 12. SOLUTION TANK

Unscrew the water inlet plug and confirm the solution filter, located on the bottom left side, is properly assembled.

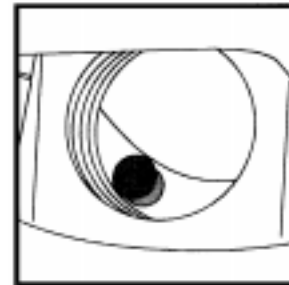

### 13. SOLUTION WATER

Fill the solution tank with clean water at a temperature not more than 50°C/122°F. Add the proper concentration of liquid detergent by following the manufacturer instructions. Excess foam in the recovery tank can damage the vacuum motor, so use only the minimum amount of detergent necessary. Reassemble the cover.



**WARNING!:** Always use low foaming detergent. Adding antifoam liquid into the recovery tank before cleaning will also help prevent foaming. **NEVER USE PURE ACID.**



### 14. ADJUSTING THE BRUSHES

Both brushes should have the same amount of contact with the floor, along their whole length.

1. Lower the brushes, set the emergency brake and turn the brushes on.
2. Turn the knob (1) to adjust the brush pressure.
3. Turn the screw (2) to obtain equal contact of the brushes with the floor (tightening the screw will increase pressure on the rear brush).



## OPERATION

### OPERATING

1. Connect the machine connector (1) to the battery connector.

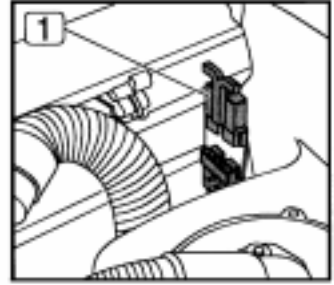

2. Turn the key (2) clockwise to ON. The green signal light will come on (3) indicating the batteries are charged (if blinking, the batteries need to be charged).
3. Press the solenoid valve switch (4).
4. Press the vacuum motor switch (5).
5. Press the brush motor switch (6).

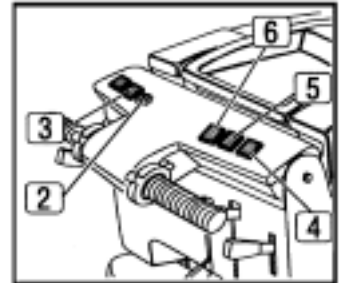

6. Adjust the amount of cleaning solution through the lever (1). There should be enough solution to wet the floor uniformly, but not so much that it gets past the splash guard. Remember that the correct solution quantity depends on the type of floor, the dirt and the speed.
7. Release the lever (2) and lower the brush base.
8. Lower the squeegee using lever (3).
9. Check that the parking brake (4) is released.

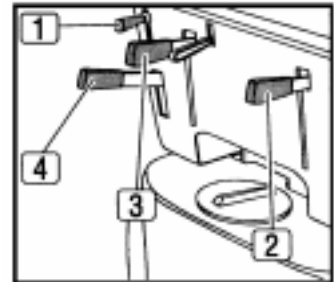

10. The machine will move by pushing the lever (1) on the handle bar forward. During the first few yards of operation, check that the quantity of the cleaning solution is sufficient and that the squeegee dries the floor surface.

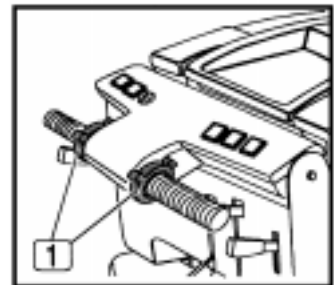

## OPERATION

**Attention:** If problems occur during operation, release the lever on the handle bar and immediately lower the brake lever located on the left side. This action will stop the machine's movement.

To restart the machine after the problem has been solved, release the parking brake lever and push the lever on the handle bar forward.

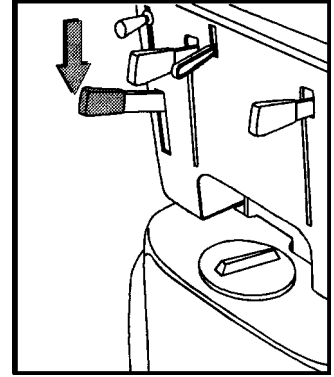

### DEVICE TOO FULL

The machine is equipped with a float that stops the vacuum when the recovery tank is full. When this occurs, empty the recovery tank by removing the plug on the drain hose.

Use gloves for protection from contact with dangerous solutions.

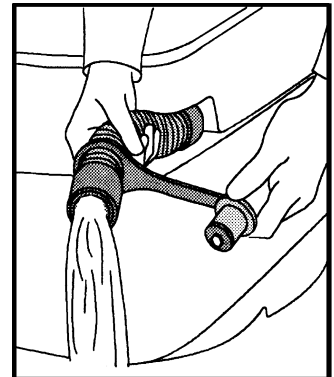

### MOVEMENT

The movement of this machine is obtained through front brush assistance. Its' harder bristles create a pulling effect.

There is no separate traction drive motor in this unit.

**WARNING!** Lift the squeegee when moving backward.

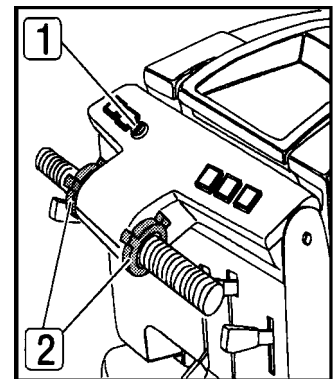

### BRAKE

The machine is equipped with a braking system controlled through the left lever (1) located on the left side, which is used as a both a parking and an emergency brake.

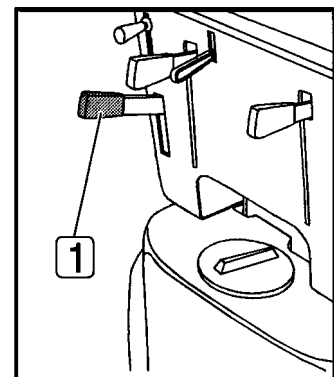

## UPON COMPLETION OF THE WORK

After finishing your work and before any type of maintenance is done, it is necessary to do the following:

1. Close the water valve through lever (1).
2. Lift the brush base with lever (2).
3. Lift the squeegee with lever (3). Note: The squeegee blades can be damaged if the squeegee is not raised during storage or transport.

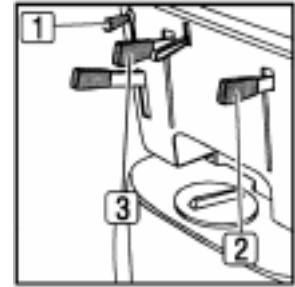

4. Switch off the solenoid valve switch (1).
5. Switch off the brush switch (2).
6. Switch off the vacuum motor switch (3).
7. Transport the machine to the location where the recovery tank should be emptied.
8. Turn the key (4) OFF.
9. Set the parking brake.

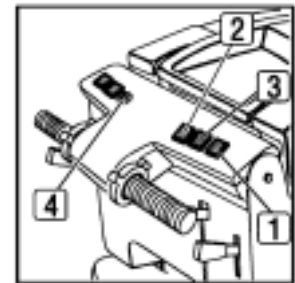

10. Pull out the hose on the front part of the recovery tank.
11. Unscrew the drain plug and empty the recovery tank.  
**Use gloves to protect yourself from contact with dangerous solutions.**
12. Take the brush off and clean it with water (for brush disassembly please read the section "DISASSEMBLY OF THE BRUSH").

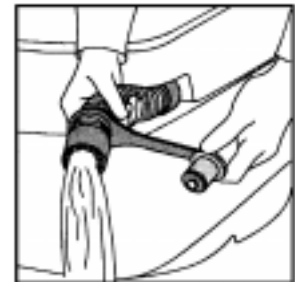

13. Slide the hopper out and clean thoroughly using gloves.



## DAILY MAINTENANCE

### CLEANING THE RECOVERY TANK

1. Pull out the hose on the front of the recovery tank.
2. Unscrew the drain plug and empty the tank.

Use gloves to protect yourself from contact with dangerous solutions

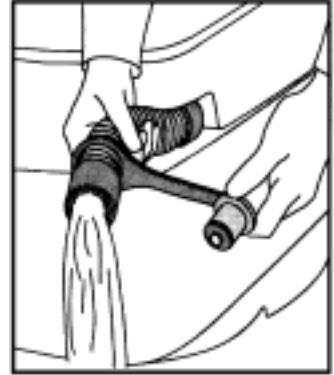

3. Lift the cover of the recovery tank.
4. Take off the vacuum plug (2) by rotating it counter-clockwise.
5. Remove the filter and its housing.
6. Rinse with water.

If a more thorough cleaning is necessary, separate the filter from its housing. Loosen the screws that lock the filter in place, then unscrew the filter from its' housing.



If removing the recovery tank, remember to detach the squeegee hose (1) and the vacuum plug (2) first. Then proceed with steps 5 and 6 above. Reassemble everything by repeating these operations in reverse.

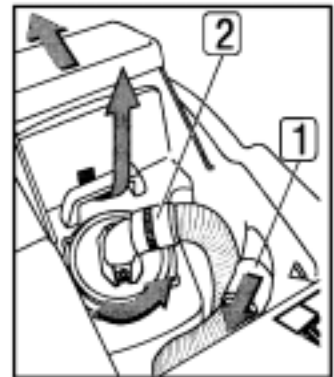

## DAILY MAINTENANCE

### CLEANING THE SOLUTION TANK FILTER

1. Unscrew the plug on the solution tank.
2. Take out the filter by pulling up on the filter cap, then clean the filter thoroughly with water.
3. Reassemble by pushing the cap until it snaps into the filter body.

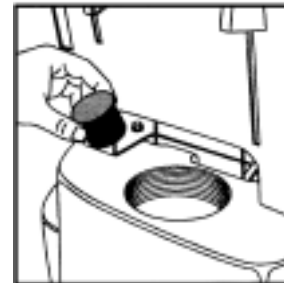

### CLEANING THE VACUUM FILTER

1. Lift the cover.
2. Take off the vacuum plug by rotating it counter-clockwise.
3. Remove the filter and its housing.
4. Use water to clean the walls and the bottom of the filter.
5. If necessary, loosen the screws which lock the filter to the housing.
6. Rotate the filter counterclockwise until it is released.
7. Wash all components thoroughly.
8. Reassemble repeating the above operations inversely.



### CLEANING THE SQUEEGEE

To obtain the best drying results, keep the squeegee clean.

To clean the squeegee it is necessary to:

1. Remove the hose from the squeegee.
2. Loosen the knobs (1).
3. Clean the inside of the squeegee thoroughly.
4. Clean the squeegee blades thoroughly.
5. Reassemble.

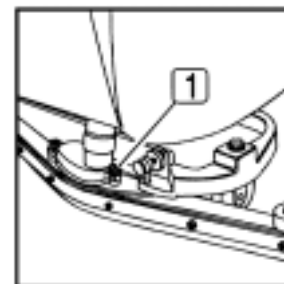

### REPLACING THE SQUEEGEE BLADES

Check the squeegee blades for wear and if necessary, change them.

To replace the squeegee blades:

1. Remove the squeegee hose from its coupling.
2. Take off the pin from the stud bolt.
3. Remove the squeegee from its support.
4. Loosen the nuts that lock the rubber blades and take them off.
5. Replace the blades.
6. To reassemble the squeegee, repeat the above operations inversely

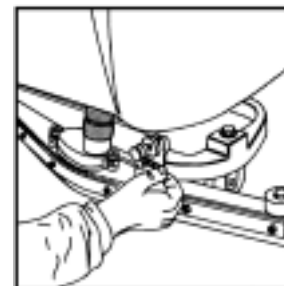

## DAILY MAINTENANCE

### DISASSEMBLY OF THE BRUSH

To remove the brushes:

1. Lift the brush base (lever 1).
2. Set the brake (lever 2).

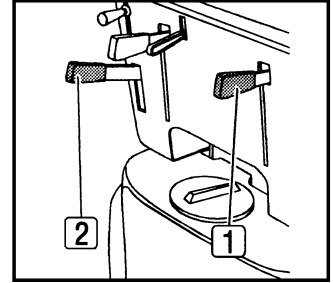

3. Clean the hopper as described on page 13.
4. Remove any strings or debris that may be preventing free brush rotation.
5. Unscrew the wing nut (1).
6. Take off the plate (2).
7. Take off the plugs (3).
8. Remove the brushes and clean.



**WARNING:** Make sure the key is turned to the OFF position.

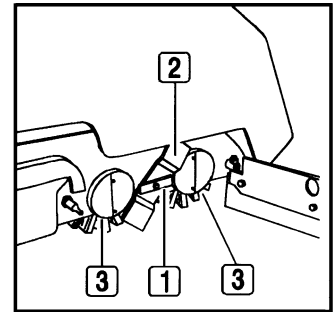



## WEEKLY MAINTENANCE

### CLEANING THE SQUEEGEE HOSE

Weekly or whenever the suction is insufficient, make sure the squeegee hose is not obstructed. To clean:

1. Take off the hose from its coupling on the squeegee.
2. Take off the other end from the recovery tank.

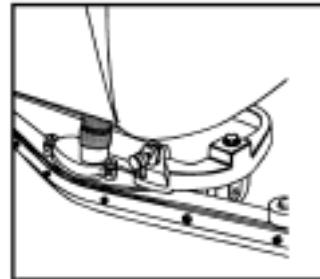

3. Wash the inner part of the hose with a water jet from the tank side.
4. Reassemble.



**WARNING!** Do not wash the hose that goes from the vacuum motor to the vacuum plug.



### CHECK BRAKE

Check the distance between the brake pads and the wheels weekly. Adjust this distance to about 1/8 inch (3mm) by adjusting the nuts shown in the diagram.

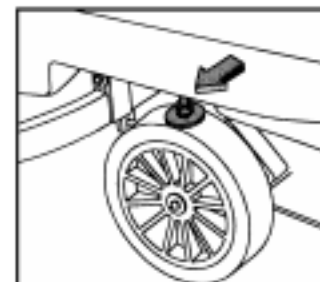

## TROUBLE SHOOTING GUIDE

### INSUFFICIENT WATER ONTO THE BRUSH

1. Make sure the water valve is open (lever 1).
2. Confirm there is water in the solution tank.
3. Make sure that the solenoid valve switch is on (button furthest on right).



### THE MACHINE DOES NOT CLEAN SATISFACTORILY

Check the condition of the brush and replace it if necessary. The brush should be replaced when the bristles reach about 5/8 inch (15mm).

### THE SQUEEGEE DOES NOT DRY THE FLOOR WELL

1. Check that the squeegee blades are clean.
2. Adjust the inclination of the squeegee (see “MACHINE PREPARATION” #9).
3. Confirm the vacuum hose is correctly fitted in its housing on the recovery tank.
4. Take off the entire vacuum assembly and clean it.
5. Replace the blades if worn.
6. Check that the vacuum motor switch is on.
7. Check the squeegee height adjustment (see “MACHINE PREPARATION #8).

### EXCESSIVE FOAM PRODUCTION

Check that a low foam detergent has been used. If required, add a small quantity of antifoam liquid into the recovery tank.

Remember that more foam is generated when the floor is not very dirty. Use less detergent if this is the case.

**REFER TO THE PARTS & SERVICE MANUAL FOR ELECTRICAL SCHEMATICS AND ADJUSTMENTS & INSPECTIONS**

**NOTES**

## WARRANTY POLICY

### PACIFIC LIMITED WARRANTY

The **Pacific** FloorMaster 18B has been manufactured, tested and inspected in accordance with specific engineering requirements. This machine is **WARRANTED** to be free from defects in workmanship and materials for periods as follows from the date of purchase.

Ten (10) Years Parts, One (1) Year Labor – Polyethylene Components

Five (5) Years Parts, One (1) Year Labor – Main Frame

Two (2) Years Parts, One (1) Year Labor – Brush Drive Motor

One (1) Year Parts & Labor – All other components unless excluded below

This warranty extends to the original user/purchaser and only when used, operated and maintained in accordance with **Pacific** Operating and Maintenance instructions.

This warranty does not apply to certain wear parts and accessories of the machine such as electrical cords, carbon motor brushes, floor brushes, belts, hoses, tools, squeegee blades, etc., nor does it apply to damage or failure caused by improper use, abuse or neglect. Warranty credit or replacement of return parts including motors, pumps, etc., is subject to incoming inspection of those items.

To secure repair under this warranty, the following procedure should be taken:

1. The inoperative machine or warranted parts must be delivered to the authorized dealer with shipping and delivery charges prepaid. If unable to locate the Dealer, you may contact **Pacific** at the address listed herein for the location of the nearest **Pacific** repair center or agent or for other instructions pertaining to your warranty difficulty.
2. Upon compliance with the above warranty procedure, all warranted repairs will be completed at no additional charge or cost to the user.
3. Only **Pacific** or its authorized dealers and agents may make no charge warranty repairs on this product. All others do so at their own risk.

This warranty limits **Pacific** liability to the repair of the product and/or warranted parts replacement and does not include incidental or consequential damages arising from the use of a **Pacific** machine whether defective or not.

#### **BATTERY WARRANTY**

In addition to the terms above, any original equipment Pacific Steamex Battery which becomes unserviceable under normal use within a period of ninety (90) days from date of sale to the original user will be repaired or replaced with one of equal specification at our option, F.O.B. any authorized Pacific Steamex Sales or Service Branch, with no charge to user, except transportation costs. After the expiration of the above ninety (90) day period, any battery which fails under normal use will be adjusted to the original user with a new battery of equal specification on a twelve (12) month pro rata basis from the date of purchase. Adjustment will be determined using the then current list price, plus transportation costs. Warranty is rendered null and void if battery is not kept filled to the proper level with DISTILLED WATER.

This warranty is in lieu of all other expressed or implied warranties and is extended to the original purchaser/user.

# PACIFIC

2259 Sheridan

Muskegon, Michigan 49442

Ph: (800) 968-1332 Fax: (231) 773-1642

[www.nextwaveofclean.com](http://www.nextwaveofclean.com)