



# Manual

The contents of this manual are based on the latest product information available at the time of publication. Pacific reserves the right to make changes or improvements to its machines without notice.

Carefully inspect all components to ensure that there is no concealed freight damage. If such damage is discovered, file a "CONCEALED DAMAGE REPORT" immediately with the delivering carrier.

FOR YOUR CONVENIENCE, RECORD THE FOLLOWING IMPORTANT INFORMATION:

For new manuals write to:

Pacific  
2259 S. Sheridan  
Muskegon, MI 49442-6252

**SERIAL NUMBER**

---

**DATE PURCHASED**

---

or download the most recent version of the manuals from our website:

[www.pacificfloorcare.com](http://www.pacificfloorcare.com)



## **READ AND UNDERSTAND ALL WARNINGS AND INSTRUCTIONS BEFORE USING THIS MACHINE!**



**WARNING!** To reduce the risk of fire, electric shock, or injury:

- 1) You must be trained to operate this machine. This machine is to be operated for its intended use only.
- 2) Do not operate this machine unless it is completely assembled.
- 3) Always use a three-wire electrical system connected to the electrical ground. For maximum protection against electrical shock, use a circuit that is protected by a ground fault circuit interrupter. Consult your electrical contractor.
- 4) To prevent electrical shock: Always remove the electrical plug from the electrical outlet before performing any repairs, maintenance or cleanup and when leaving the machine unattended.
- 5) To prevent electrical shock: Keep the machine surface dry; Do not subject to rain; Store the machine in a dry building area; Clean the machine with a dry cloth only.
- 6) Machines can cause an explosion when near flammable materials and vapors. Do not use or store this machine with or near fuels, grain dust, solvents, thinners, or other flammable materials. Do not use flammables to clean this machine.
- 7) Maintenance and repairs must be done by a qualified or authorized person.
- 8) If the machine is not working as it should, has been dropped, damaged, left outdoors, or dropped into water, return it to a service center.
- 9) To avoid damage to the machine's electrical cord, always lift the machine over the cord. Do not run the machine over the electrical cord.
- 10) Make sure all labels, decals, warnings, cautions and instructions are fastened to the machine.



## **Grounding Instructions**

This machine must be grounded. If it should malfunction or break down, grounding provides a path of least resistance for electric current to reduce the risk of electric shock. This machine is equipped with a cord having an equipment-grounding conductor and grounding plug. The plug must be inserted into an appropriate outlet that is properly installed and grounded in accordance with all local codes and ordinances.



**WARNING!** - Improper connection of the equipment-grounding conductor can result in a risk of electric shock. Check with a qualified electrician or service person if you are in doubt as to whether the outlet is properly grounded. Do not modify the plug provided with the machine - if it will not fit the outlet, have a proper outlet installed by a qualified electrician.

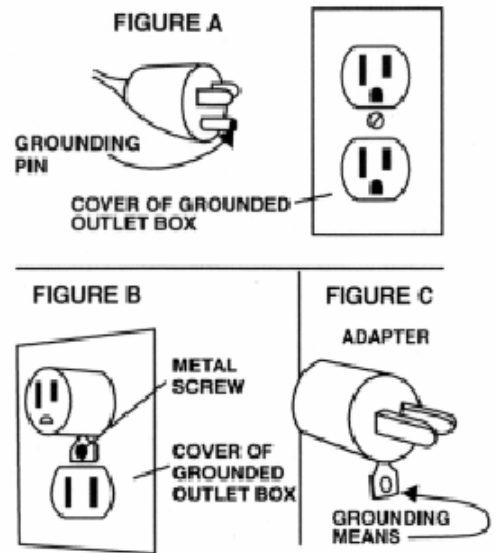

This machine is for use on a nominal 120-volt circuit, and has a grounded plug that looks like the plug illustrated in figure A. A temporary adapter that looks like the adapter illustrated in figures B and C may be used to connect this plug to a 2-pole receptacle as shown in figure B if a properly grounded outlet is not available. The temporary adapter should be used only until a properly grounded outlet (figure A) can be installed by a qualified electrician. The green colored rigid ear, lug, or the like extending from the adapter must be connected to a permanent ground such as a properly grounded outlet box cover. Whenever the adapter is used, it must be held in place by a metal screw.

*NOTE: In Canada, the use of a temporary adapter is not permitted by the Canadian Electrical Code*

## **EXTENSION CORDS**

Use only three-wire 16/3 or larger gauge approved extension cords that have three-prong grounding type plugs and three-pole receptacles that accept the appliance's plug. Replace or repair any damaged cords or plugs.

When servicing, refer to authorized person only. Use only identical replacement parts.



PACIFIC

## OPERATING PROCEDURES



**WARNING!** - For the safe operation of this machine follow the instructions given in this booklet and the training given by your supervisor. Failure to do so can result in personal injury and/or damage to machine and property!

**DO NOT OPERATE MACHINE IN AN EXPLOSIVE ENVIRONMENT!**



**WARNING!** - NEVER USE THIS MACHINE TO PICK UP VOLATILE OR EXPLOSIVE MATERIALS.

### OPERATION

To prepare the machine for operation, make sure it is of the correct voltage and properly assembled. If in doubt, ask your supervisor.

#### FOR DRY PICK-UP:

“Dry” refers to material such as dust, dirt, debris and dry foam shampoo.

- 1) Release the clamps on the sides of the tank and head assembly. Lift the head assembly off and set it aside.
- 2) Then lift the cloth filter assembly out of the collector tank. Clean the cloth filter if needed (reference the “Maintenance” section).
- 3) Empty the collector tank of all dust and debris. If the debris is wet, empty and dry the inside of the tank thoroughly.
- 4) Place the cloth filter assembly back into the collector tank. Check for a good seal around the outer filter lip and tank rim.
- 5) Replace the head assembly and fasten the clamps. Attach the hose, wand and floor tool of choice.
- 6) Plug the power cord into a 120-volt, 60 cycle grounded outlet.
- 7) Turn the machine’s motor on by pressing the rocker switch which is located on the head assembly.



**FOR WET PICK-UP:**

“Wet” refers to liquids such as water, scrub solutions and detergents; **NOT** volatile or explosive materials.

- 1) Release the clamps on the sides of the tank and head assembly. Lift the head assembly off and set it aside.
- 2) Then lift the cloth filter assembly out of the collector tank. Store the filter assembly for future, dry pick-up use. **DO NOT REINSTALL.**
- 3) Empty the collector tank of all dust and debris. Also wipe the inside of the collector tank to remove clinging dust.
- 4) Check the float shut-off device on the lower portion of the head assembly. The float should have free movement. When the recovered liquid soilage reaches the collector tank capacity, the float will rise to shut off the air flow, stopping the liquid recovery. This prevents damaging overflow and signals the operator when to empty the collector tank.
- 5) Replace the head assembly and fasten the clamps. Attach the hose, wand and floor tool of choice (reference page 5).
- 6) Plug the power cord into a 120-volt, 60 cycle grounded outlet.
- 7) Turn the machine’s motor on by pressing the rocker switch which is located on the head assembly.



**Good maintenance procedures assure better operation, fewer repairs and longer life for your machine.**



**WARNING! - DISCONNECT THE ELECTRICAL PLUG OF THE MACHINE FROM THE ELECTRICAL OUTLET BEFORE DOING ANY CLEANUP, REPAIRS OR MAINTENANCE OF THE MACHINE AND WHEN LEAVING THE MACHINE UNATTENDED.**

**CLEAN THE MACHINE AFTER EACH USE:**

- 1) Wipe the outside with a clean dry cloth.
- 2) Clean the collector tank: Release the clamps on each side of the tank and head assembly. Lift the head assembly off and set aside. Lift the filter assembly out of the collector tank and set aside. Then wipe the inside of the collector tank with a clean dry cloth.
- 3) Empty and check the filter assembly: Empty the recovered soilage into a suitable container and shake to remove clinging dirt. Brush the outside of the filter bag to remove embedded dirt. Check the filter assembly for tears or holes; repair or replace if necessary. Install the clean filter assembly into the clean collector tank.

**ELECTRICAL CABLE:**

Check the cord for any nicks, cuts or damage. Report these to your supervisor for correction.

**VACUUM HEAD ASSEMBLY:**

- 1) Gaskets: Clean the vacuum head gasket and the float shut-off gasket.
- 2) Float Shut-Off Device: This should move freely. Remove any debris or strings from the float cage.
- 3) Head Assembly: Replace and leave ajar if the collector tank is damp to prevent mildew.

**WHEELS AND CASTERS:**

Check these for cuts and nicks. Remove any strings or debris that may restrict the free movement of the wheels. Wipe the treads clean.

**CARBON BRUSH INSPECTION:**

Check for wear at six month intervals or every 600 hours of operation. The carbon brushes must be replaced if worn shorter than 3/8 inch.



PACIFIC

**TROUBLE SHOOTING:**

<b>FAULT</b>	<b>CAUSE</b>	<b>REMEDY</b>
Vacuum motor does not start	No electrical power	Check fuse, cable, plug and socket
Suction slowly decreases	Filter, nozzle, suction hose or extension tube blocked	Check and clean
Suction suddenly decreases	The filter bag or the tank is full	Turn off the vacuum and empty
Dust escapes when cleaning	Filter incorrectly placed or defective	Check filter sealing. Replace filter



Vacuum Assembly

Drawing 1

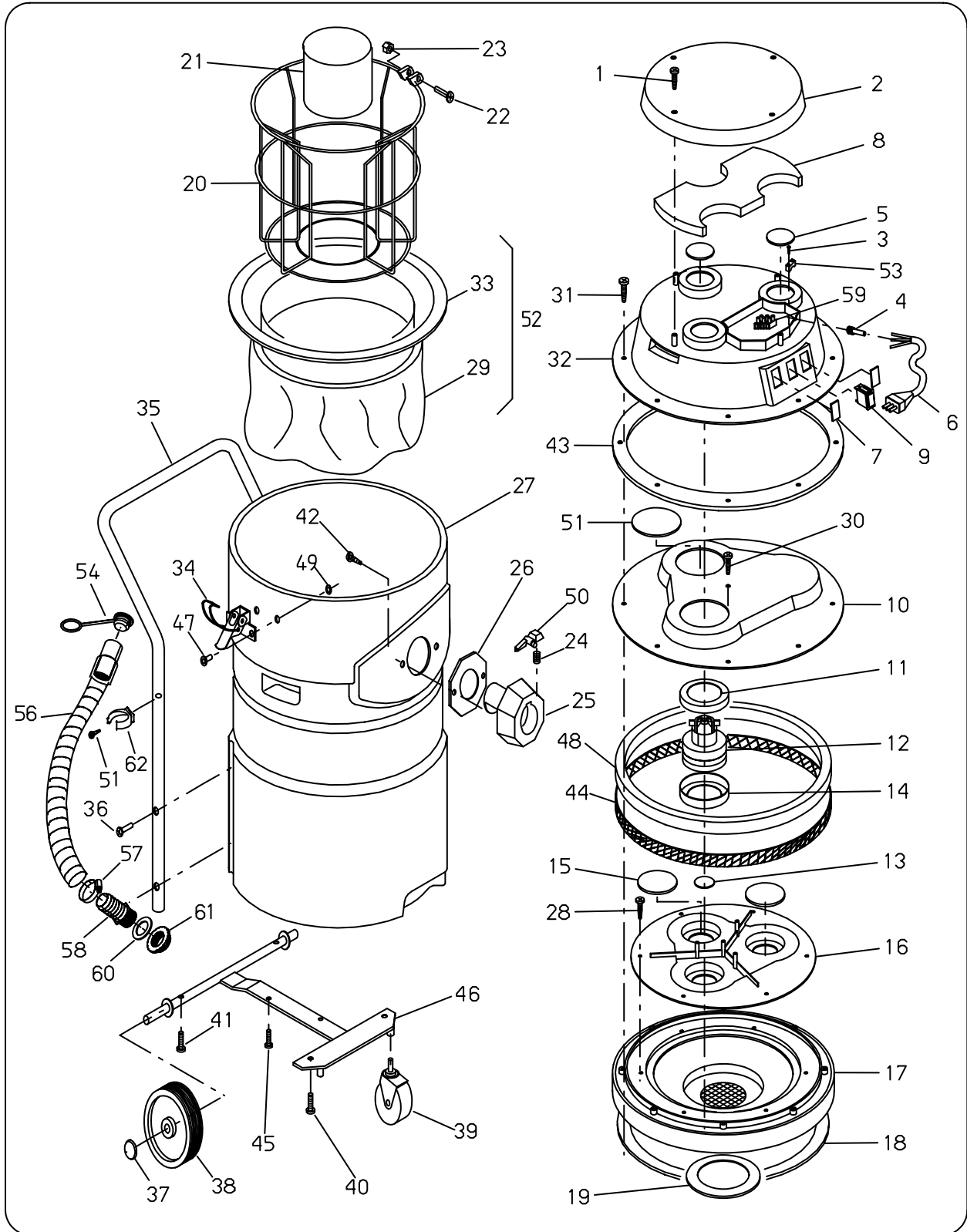





PACIFIC

VACUUM ASSEMBLY			
Item	Part Number	Qty	Description
1	964143	4	SCREW
2	601550	1	COVER
3	964165	2	SCREW
4	608511	1	GOMET
5	604611	2	DOME PLUG
6	908104	1	ELECTRIC CABLE
7	604610	2	PLUG PLATE
8	608513	1	STANDOFF
9	608010	1	ROCKER SWITCH
10	600220	1	COVER
11	603410	1	GASKET
12	605210	1	VACUUM MOTOR
13	604612	1	MOTOR VALVE
14	603410	1	GASKET
15	604613	2	PLUG
16	600221	1	LOWER VACUUM MOUNT
17	600222	1	POWER HEAD BASE
18	603421	1	POWER HEAD GASKET
19	603422	1	GASKET - SHUT OFF FLOAT
20	602420	1	FLOAT CAGE
21	603312	1	FLOAT SHUT OFF
22	964139	1	SCREW
23	920628	1	NUT
24	608303	1	SPRING
25	602415	1	TANK INTAKE
26	603415	1	GASKET-TANK INTAKE
27	608616	1	TANK
28	964024	6	SCREW
29	See Item 52	1	FILTER BAG
30	964028	4	SCREW
31	964028	8	SCREW
32	602350	1	VACUUM MOTOR COVER
33	See Item 52	1	FILTER RING
34	602010	2	CLAMP
35	603909	1	HANDLE
36	964166	4	SCREW
37	601509	2	WHEEL RETAINER
38	609713	2	WHEEL
39	609714	2	CASTER WHEEL
40	964167	2	SCREW
41	964166	2	SCREW
42	964144	2	SCREW
43	607302	1	RING
44	605701	1	ALUMINUM NET
45	964168	2	SCREW
46	601308	1	TANK MOUNTING BASE
47	930010	4	RIVET
48	607303	1	RING
49	980011	4	WASHER
50	607001	1	LATCH
51	606801	1	PLUG
52	600540	1	FILTER BAG ASSEMBLY
53	602009	1	U BOLT
54	606802	1	HOSE PLUG
56	604116	1	DRAIN HOSE
57	602013	1	HOSE CLAMP
58	603314	1	BARBED FITTING
59	911267	1	TERMINAL BLOCK
60	603416	1	GASKET
61	607304	1	FITTING RING
62	602102	1	HOSE CLIP



Squeegee Assembly

Drawing 2

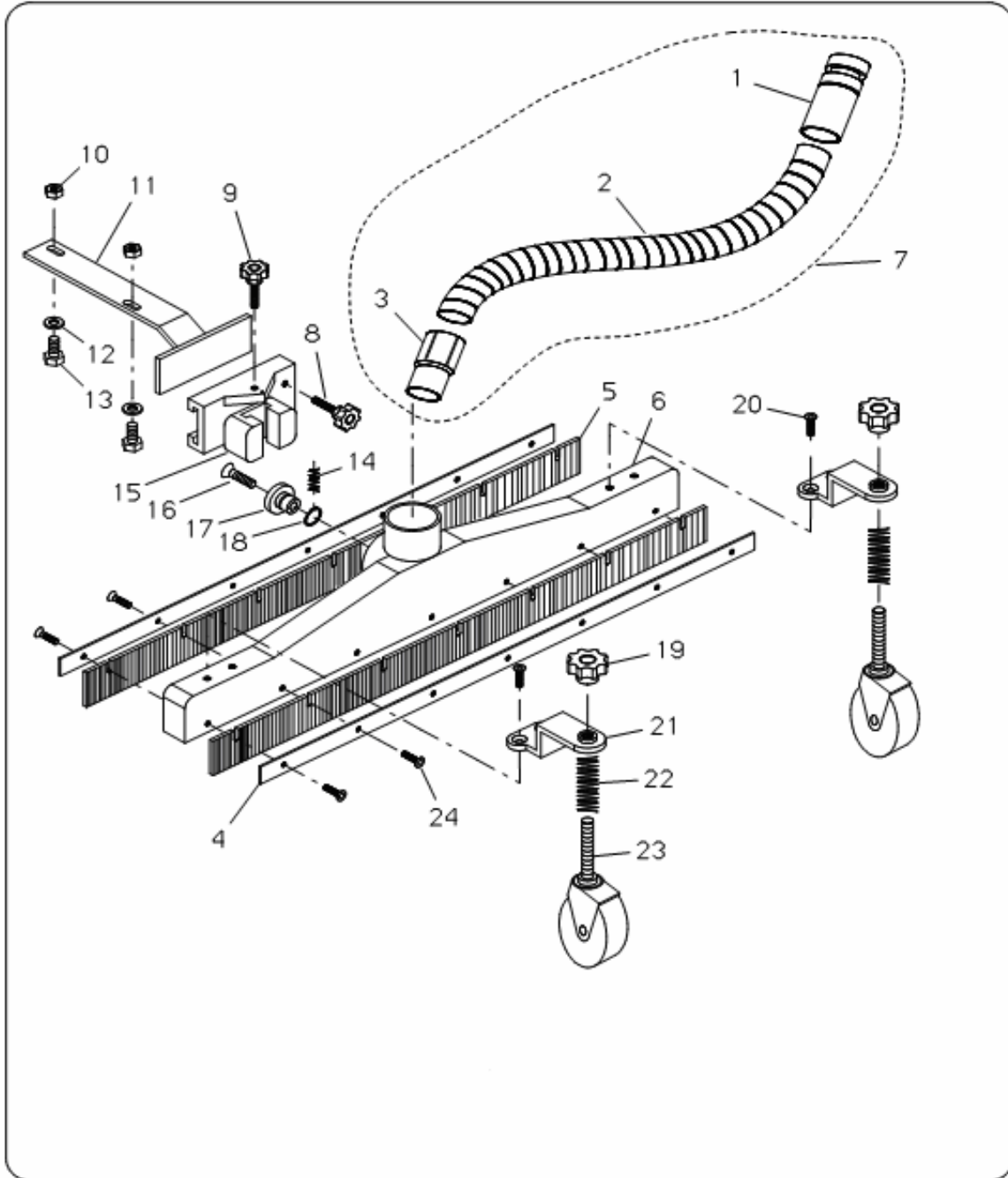



PACIFIC

<b>SQUEEGEE ASSEMBLY</b>			
<b>Item</b>	<b>Part Number</b>	<b>Qty</b>	<b>DESCRIPTION</b>
1	600206	1	ROTATING CUFF
2	604112	1	VACUUM HOSE
3	600205	1	FIXED CUFF
4	601311	2	CLAMP BAR
5	600708	2	RUBBER BLADE
6	601806	1	SQUEEGEE CASTING
7	604117	1	HOSE ASSEMBLY
8	605001	1	KNOB
9	605002	1	KNOB
10	924021	2	NUT
11	600812	1	SQUEEGEE MOUNT
12	980635	2	WASHER
13	964198	2	SCREW
14	608302	1	SPRING
15	600802	1	SQUEEGEE SUPPORT
16	964199	1	SCREW
17	601101	1	BUSHING
18	602101	1	RETAINING RING
19	605003	2	KNOB
20	964200	4	SCREW
21	600803	2	WHEEL SUPPORT
22	608301	2	SPRING
23	609701	2	CASTOR
24	964201	14	SCREW



## **WARRANTY POLICY PACIFIC LIMITED WARRANTY**

The **Pacific** Gulper 16SV Wet/Dry Vacuum has been manufactured, tested and inspected in accordance with specific engineering requirements. This machine is **WARRANTED** to be free from defects in workmanship and materials for periods as follows from the date of purchase.

Five (5) Years Parts, One (1) Year Labor – Polyethylene Components  
One (1) Year Parts & Labor – All other components unless excluded below

This warranty extends to the original user/purchaser and only when used, operated and maintained in accordance with **Pacific** Operating and Maintenance instructions.

This warranty does not apply to certain wear parts and accessories of the machine such as electrical cords, carbon motor brushes, floor brushes, belts, hoses, tools, squeegee blades, etc., nor does it apply to damage or failure caused by improper use, abuse or neglect. Warranty credit of return parts including motors, etc., is subject to incoming inspection of those items.

To secure repair under this warranty, the following procedure should be taken:

- 1) The inoperative machine or warranted part must be delivered to the authorized dealer with shipping and delivery charges prepaid. If unable to locate the Dealer, you may contact **Pacific** at the address listed herein for the location of the nearest **Pacific** repair center or agent or for other instructions pertaining to your warranty difficulty.
- 2) Upon compliance with the above warranty procedure, all warranted repairs will be completed at no additional charge or cost to the user.
- 3) Only **Pacific** or its authorized dealers and agents may make no charge warranty repairs on this product. All others do so at their own risk.

This warranty limits **Pacific** liability to the repair of the product and/or warranted parts replacement and does not include incidental or consequential damages arising from the use of a **Pacific** machine whether defective or not.

This warranty is in lieu of all other expressed or implied warranties and is extended to the original purchaser/user.