



PERFORMANCE SERIES VACUUMS Parts Manual

INTRODUCTION

OPERATING & MAINTENANCE INSTRUCTIONS

READ THIS BOOK

This operator's book has important information for the use and safe operation of this machine. Read this book carefully before starting the machine. Keep this book and tell all operators to read the book. If you do not follow the instructions, you can cause an injury or damage equipment, furniture or buildings.

For new books write to:

Pacific
2259 South Sheridan Road
Muskegon, MI 49442

Carefully inspect all components to ensure that there is no concealed freight damage. If such damage is discovered, file a "CONCEALED DAMAGE REPORT" immediately with the delivering carrier.

The contents of this manual are based on the latest product information available at the time of publication. **Pacific** reserves the right to make changes or improvements to its machines without notice.

FOR YOUR CONVENIENCE, RECORD THE FOLLOWING IMPORTANT INFORMATION:

MODEL _____

SERIAL NUMBER _____

PART NUMBER _____

DATE PURCHASED _____

IMPORTANT SAFETY INSTRUCTIONS

READ AND UNDERSTAND ALL WARNINGS AND INSTRUCTIONS IN THIS BOOK BEFORE USING THIS MACHINE! If you do not understand, ask your supervisor.

WARNING: To reduce the risk of fire, electric shock, or injury:

1. DO NOT USE THESE VACUUMS FOR PICK UP OF WET DEBRIS.
2. Do not use outdoors or on wet surfaces.
3. Do not allow to be used as a toy. Close attention is necessary when used by or near children.
4. You must be trained to operate this machine. Operate this machine for its intended use only.
5. Do not operate this machine unless it is completely assembled. The dust bag and/or filters must be in place.
6. Keep the machine and its electrical components dry. Do not subject to rain. Store the machine in a dry building area. Clean the machine with a dry cloth only.
7. Machines can cause an explosion when near flammable materials and vapors. Do not use or store this machine with or near fuels, grain dust, solvents, thinners, or other flammable materials. Do not use flammables to clean this machine.
8. Do not pick up anything that is burning or smoking, such as cigarettes, matches or hot ashes.
9. Maintenance and repairs must be done by a qualified or authorized service center.
10. If the machine is not working as it should, has been dropped, damaged, left outdoors, or dropped into water, return it to a service center.
11. Connect to a properly grounded outlet only (See Grounding Instructions).
12. To prevent electric shock, always remove the electrical plug from the electrical outlet before doing any repairs or maintenance and when leaving the machine unattended. Do not handle plug or vacuum with wet hands.
13. Do not pull cord, use cord as a handle, close a door on cord, or pull cord around sharp edges or corners. Keep cord away from heated surfaces. Do not use with damaged cord or plug.
14. Turn off all controls before unplugging.
15. Do not put objects into openings. Do not use with any opening blocked: keep free of dust, lint, hair and anything that may reduce airflow.
16. Keep hair, loose clothing, fingers and all parts of the body away from openings and moving parts.
17. Make sure all labels, decals, warnings, cautions and instructions are fastened to the machine.

Grounding Instructions

This machine must be grounded. If it should malfunction or break down, grounding provides a path of least resistance for electric current to reduce the risk of electric shock. This machine is equipped with a cord having an equipment-grounding conductor and grounding plug. The plug must be inserted into an appropriate outlet that is properly installed and grounded in accordance with all local codes and ordinances.

WARNING - Improper connection of the equipment-grounding conductor can result in a risk of electric shock. Check with a qualified electrician or service person if you are in doubt as to whether the outlet is properly grounded. Do not modify the plug provided with the machine - if it will not fit the outlet, have a proper outlet installed by a qualified electrician.

This machine is for use on a nominal 120-volt circuit, and has a grounded plug that looks like the plug illustrated in figure A. A temporary adapter that looks like the adapter illustrated in figures B and C may be used to connect this plug to a 2-pole receptacle as shown in figure B if a properly grounded outlet is not available. The temporary adapter should be used only until a properly grounded outlet (figure A) can be installed by a qualified electrician. The green colored rigid ear, lug, or the like extending from the adapter must be connected to a permanent ground such as a properly grounded outlet box cover. Whenever the adapter is used, it must be held in place by a metal screw.

NOTE: In Canada, the use of a temporary adapter is not permitted by the Canadian Electrical Code

EXTENSION CORDS

Use only three-wire 14/3 or larger gauge approved extension cords that have three-prong grounding type plugs and three-pole receptacles that accept the appliance's plug. Replace or repair any damaged cords or plugs.

When servicing, refer to authorized person only. Use only identical replacement parts.

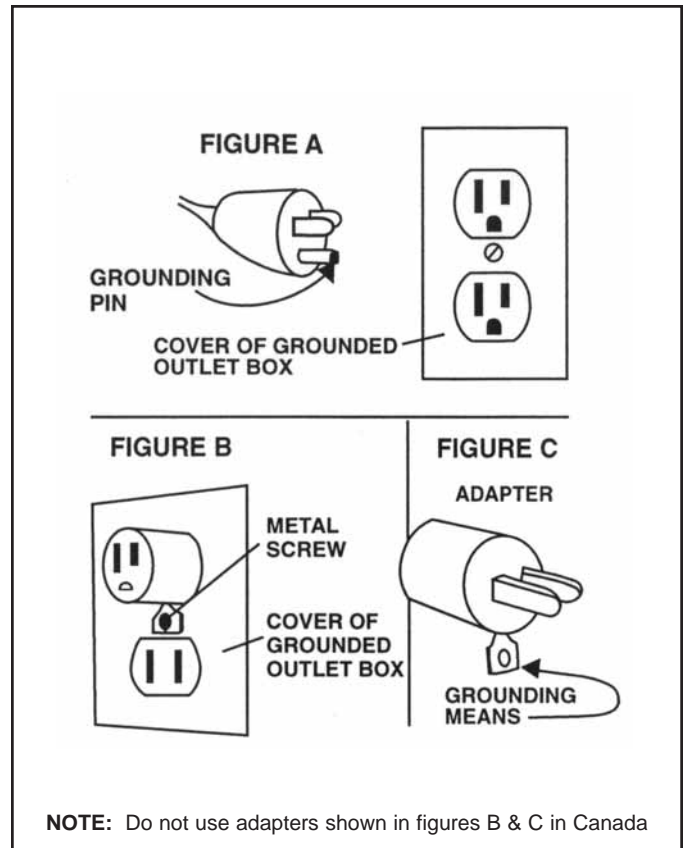

OPERATING PROCEDURES

WARNING! For the safe operation of this machine follow the instructions given in this booklet and the training given by your supervisor. Failure to do so can result in personal injury and/or damage to machine and property!

DO NOT OPERATE MACHINE IN AN EXPLOSIVE ENVIRONMENT!

NEVER USE THIS MACHINE TO PICK UP VOLATILE OR EXPLOSIVE MATERIALS!

The model shown in this manual is intended for commercial use.

PREPARATION

Please see the operating instructions manual included with your unit for assembly instructions.

OPERATION

1. **Plug the machine's power cable into a properly grounded outlet** (see Grounding Instructions).
2. **Release the handle by stepping on the pedal and lowering handle until motor starts. To lower handle further (for cleaning under objects), step on pedal again and lower handle as much as necessary.**
3. **Use short back and forth strokes to cover small areas.**
4. **To turn the unit off, raise the handle to the upright position.**
5. **The necessary time to properly clean carpet depends on the carpet thickness and the amount of dust/dirt.**
6. **To store your upright, roll the cable trying not to twist it and hang it from the cord hook at the top part of the handle tube.**
7. **Make sure that the height of the vacuum is adjusted to the proper level using the height adjustment knob on the hood of the unit.**

MAINTENANCE

ALWAYS turn the vacuum **OFF** and **UNPLUG** the power cord from the electrical outlet before doing any clean-up or repairs, and when the machine is left unattended.

AFTER EACH USE:

1. **Vacuum filter bag:** If the bag is full or damaged install a new one.
HEPA Paper Bag, 3 Pack - Part # 660605
Standard Paper Bag, 3 Pack – Part # 660601
Cloth Shake Out Bag (optional) – Part # 660615
2. **Power cord and plug:** Check for cuts or nicks; if damaged, have the cord replaced at a factory authorized service center.
3. **Wheels:** Remove any strings or debris that may restrict the free movement of the wheels.
4. **Brush:** Remove any strings or debris. Replace if becomes worn or damaged.

Storage: Store the machine in a clean dry area.

VACUUM MOTOR MAINTENANCE:

Have the vacuum motor inspected annually by a factory authorized service technician. This service will prolong the life of the motor.

NOTES

PERFORMANCE 127G EXTERNAL PARTS

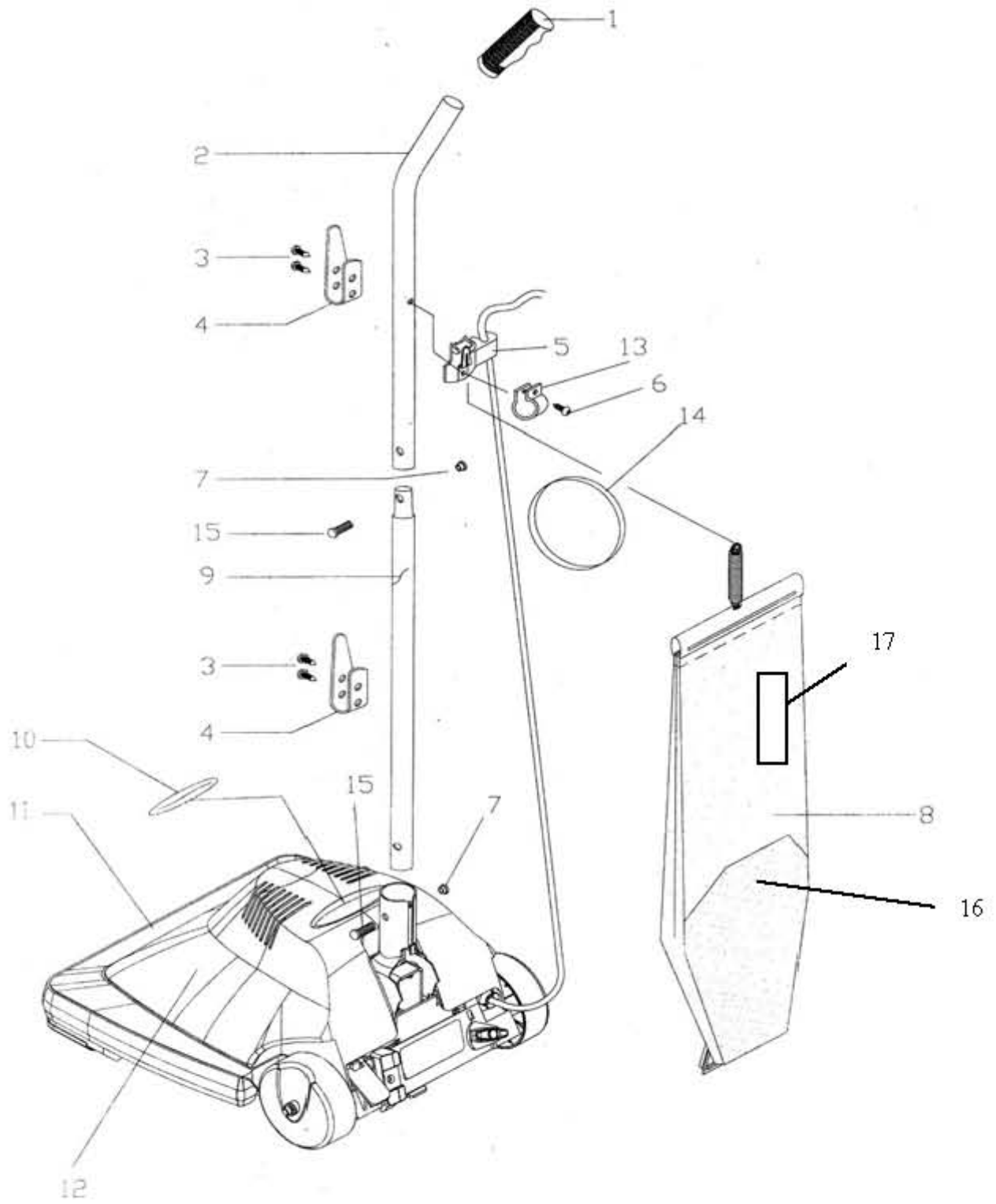

PERFORMANCE 127G EXTERNAL PARTS LIST

ITEM #	PART #	DESCRIPTION	QTY
1	663901	GRIP-HANDLE	1
2	669002	HANDLE-UPPER BLACK	1
3	962242	SCREW 10 X 3/8	4
4	664502	CORD HOOK-BLACK	2
5	667204	RETAINER-CORD	1
6	962251	SCREW 8 X 1/2 CAB	1
7	W526D	NUT-UPRIGHT HANDLE 10-32 NYLON	2
8	660625	ZIPPER BAG ASSEMBLY	1
9	669001	HANDLE-LOWER BLACK	1
10	665101	LABEL-COMMERCIAL FOR HOOD	1
11	664202	CHASSIS	1
12	662301	HOOD	1
13	662103	CLIP-BELT RETAINING	1
14	903040	BELT-POLY .210 X 13 7/16-83A	1
15	962258	SCREW-SPECIAL HANDLE (2 PIECES)	2
16	660605	HEPA PAPER BAG PACKAGE (3 BAGS)	1
17	665102	LABEL-CRI CERTIFICATION	1

PERFORMANCE 127DC EXTERNAL PARTS

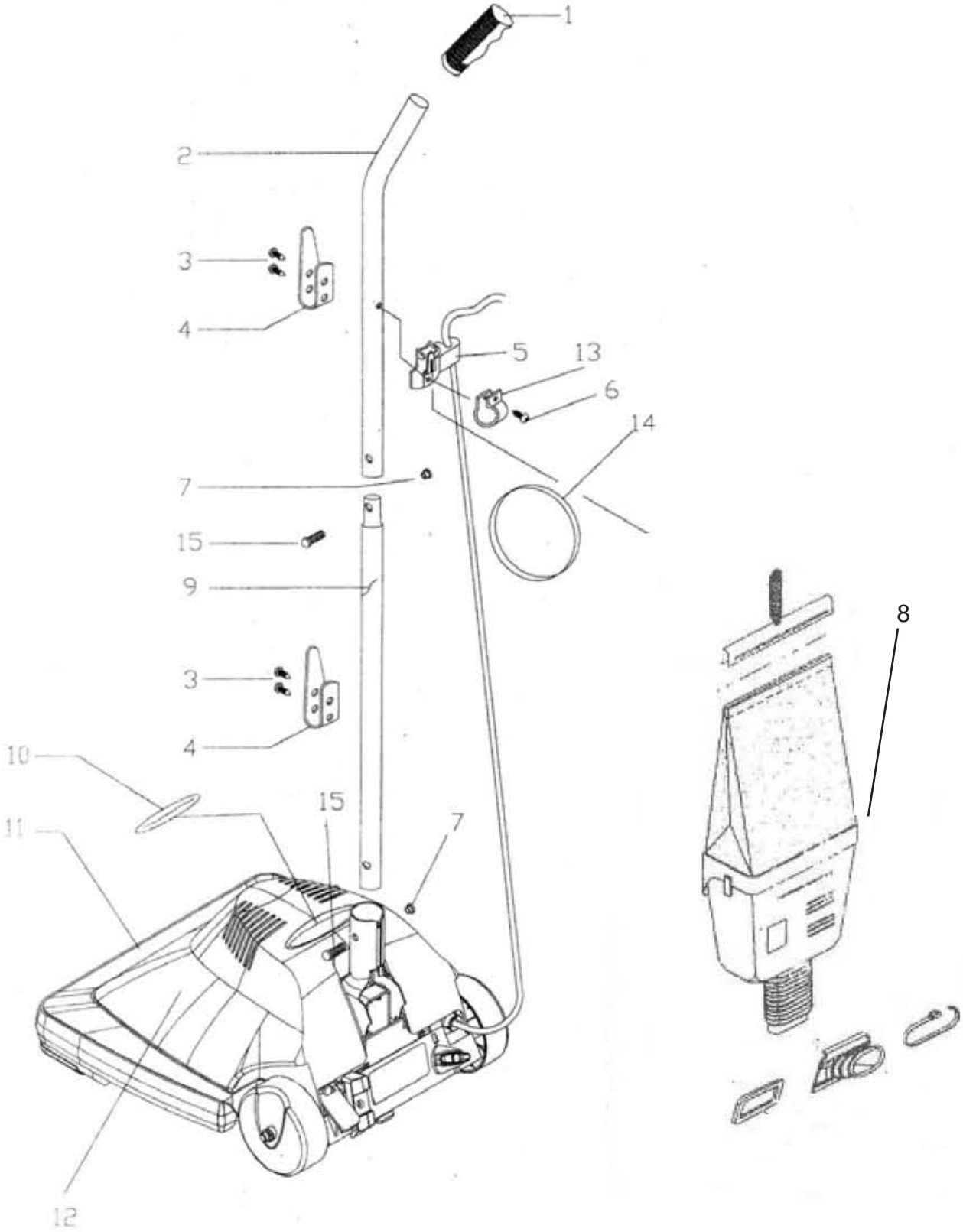

PERFORMANCE 127DC EXTERNAL PARTS LIST

ITEM #	PART #	DESCRIPTION	QTY
1	663901	GRIP-HANDLE	1
2	669002	HANDLE-UPPER BLACK	1
3	962242	SCREW 10 X 3/8	4
4	664502	CORD HOOK-BLACK	2
5	667204	RETAINER-CORD	1
6	962251	SCREW 8 X 1/2 CAB	1
7	W526D	NUT-UPRIGHT HANDLE 10-32 NYLON	2
8	660630	DIRT CUP BAG ASSM	1
9	669001	HANDLE-LOWER BLACK	1
10	665101	LABEL-COMMERCIAL FOR HOOD	1
11	664202	CHASSIS	1
12	662301	HOOD	1
13	662103	CLIP-BELT RETAINING	1
14	903040	BELT-POLY .210 X 13 7/16-83A	1
15	962258	SPECIAL HANDLE SCREW (2 PIECES)	2

PERFORMANCE 127G & 127DC INTERNAL PARTS

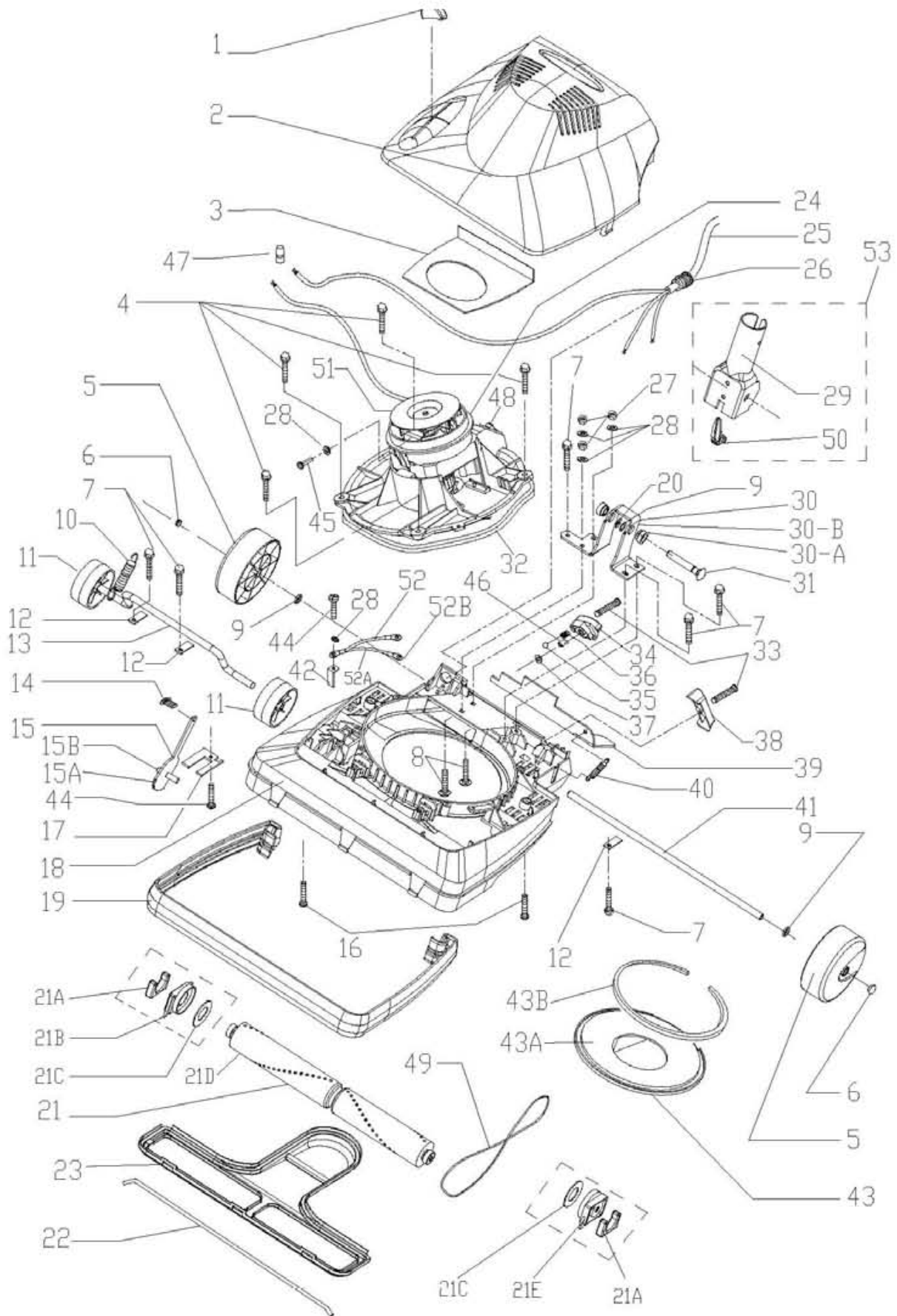

PERFORMANCE 127G & 127DC INTERNAL PARTS LIST

ITEM #	PART #	DESCRIPTION	QTY
1	665002	KNOB-HEIGHT ADJUSTMENT	1
2	662301	HOOD-PACIFIC YELLOW 127	1
3	663401	BAFFLE-MOTOR	1
4	962254	SCREW B 10-16 X 3/4	4
5	669701	WHEEL-REAR	2
6	924084	NUT-BLIND	2
7	962256	SCREW-HEX 10-16 X 5/8	6
8	962243	SCREW 10 X 5/8	2
9	980714	WASHER-FLAT 5/16 X 1/2	3
10	668301	SPRING-FRONT AXLE	1
11	667501	WHEEL-FRONT	2
12	667201	PLATE-AXLE RETAINING	3
13	660501	AXLE-FRONT	1
14	962257	SCREW-SELF TAPPING BT 6	1
15	661401	CAM ASSM	1
15-A	661402	CAM-HANDLE	1
15-B	667701	SHAFT-CAM	1
16	962248	SCREW 6 X 5/8 BC PH	2
17	661404	PLATE-CAM	1
18	664202	CHASSIS	1
19	661201	BUMPER-BLACK	1
20	980708	WASHER-C PO-25	1
21	660901	BRUSH ROLL ASSM-12"	1
21-A	663402	GASKET-END CAP	1
21-B	902039	SUPPORT-LEFT BEARING	1
21-C	669801	WASHER-FELT	2
21-D	n/a	BRUSH ROLL W/O ENDCAPS	1
21-E	902040	BALL BEARING-RIGHT 11/16	1
22	667202	BAR-BOTTOM PLATE RETAINER	1
23	667901	BOTTOM PLATE	1
24	662701	AIR DUCT	1
25	668001	CORD ASSM-LINE	1
26	663801	GROMMET H1232	1
27	W106D	NUT-HEX No.10-24	3

ITEM #	PART #	DESCRIPTION	QTY
28	980718	WASHER-STAR 10 X .204	5
29	664901	YOKE	1
30	666601	YOKE SUPPORT ASSM	1
30-A	668201	SPACER-YOKE	2
30-B	666602	SUPPORT-YOKE	1
31	667702	SHAFT-YOKE	1
32	663403	GASKET-MOTOR BASE	1
33	962252	SCREW 8 X 3/4 CAB	2
34	665003	KNOB-BAG	1
35	667705	SHAFT-BALL ARM	1
36	668302	SPRING-KNOB	1
37	980710	WASHER-FLAT (02-0101)	1
38	667203	RETAINER-UPRIGHT BAG	1
39	667004	PEDAL	1
40	668304	SPRING-HANDLE CAM	1
41	667703	AXLE-REAR WHEEL	1
42	980715	WASHER-GROUND	1
43	662303	FAN COVER W/ GASKET ASSM (NOT SOLD SEPARATELY)	2
43-A	n/a	COVER-FAN (NOT SOLD SEPARATELY)	1
43-B	n/a	GASKET-FAN COVER	1
44	962246	SCREW 6 X 3/8 "A" PH CAB	2
45	962255	SCREW T 8-32 X 1/4	1
46	664701	SPACER-BAG KNOB	1
47	911537	CONNECTOR	1
48	911533	SWITCH-UPRIGHT	1
49	903040	BELT-POLY .210 X 13 7/16-83A	1
50	911534	ACTUATOR-SWITCH	1
51	665201	MOTOR ASSM	1
52	911535	LEAD-GROUND	1
52-A	n/a	CORD-GREEN GROUNDED	2
52-B	n/a	TERMINAL-GROUNDED CONNECTION	3
53	911536	ACTUATOR SWITCH ASSM	1
	665004	LEXAN FAN KIT (NOT SHOWN)	1
	W527D	NUT-PULLEY (NOT SHOWN)	1

PERFORMANCE 128G & 128DC EXTERNAL PARTS

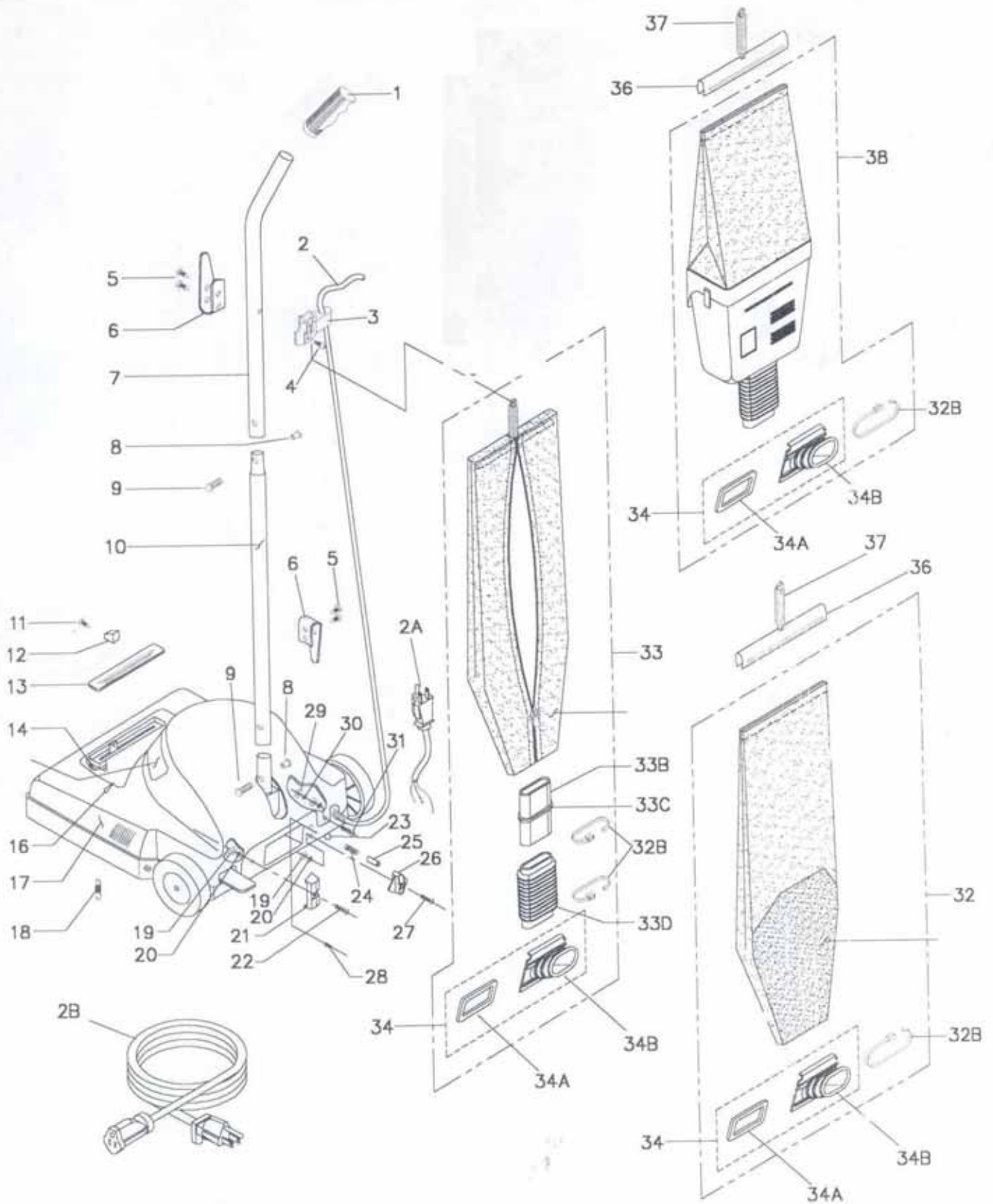

PERFORMANCE 128G & 128DC EXTERNAL PARTS LIST

ITEM #	PART #	DESCRIPTION	QTY
1	663901	GRIP-HANDLE	1
2A	668002	CORD ASSM-3"	1
2B	908113	CORD-50' EXTENSION	1
3	667204	RETAINER-CORD	1
4	962251	SCREW 8 X 1/2 CAB	1
5	962242	SCREW 10 X 3/8	4
6	664501	CORD HOOK	2
7	669004	HANDLE-UPPER	1
8	W526D	NUT-UPRIGHT HANDLE 10-32 NYLON	2
9	962259	SPECIAL HANDLE SCREW (2 PIECES)	2
10	669003	HANDLE-LOWER	1
11	962246	SCREW 6 X 3/8 "A" PH CAB	1
12	665005	KNOB-HEIGHT ADJUSTMENT	1
13		N/A	
14	667601	FELT	1
15		N/A	
16	665103	LABEL-HEIGHT ADJUSTMENT	1
17	662302	HOOD	1
18	668311	SPRING-HOOD	2
19	W525D	NUT 10-32	2
20	980718	WASHER-STAR 10 X .204	2
21	667203	RETAINER-UPRIGHT BAG	1
22	962244	SCREW 10-30 X 5/8	1
23	667705	SHAFT-BALL ARM	1
24	668302	SPRING-KNOB	1
25	664701	SPACER-BAG KNOB	1
26	665003	KNOB-BAG	1
27	962003	SCREW 10-32 x 3/4	1
28	962247	SCREW 6 X 5/16	1
29	W143D	NUT HEX 8-32	2
30	980718	WASHER-STAR 10 X .204	2
31	962063	SCREW 8-32 X 3/8	1
32	660615	CLOTH SHAKE OUT BAG ASSM (OPTIONAL)	1
32A		N/A	
32B	668501	STRAP-PLASTIC	2
33	660625	ZIPPER BAG ASSM	1
33A		N/A	
33B	662402	CONNECTOR-PAPER BAG	1
33C	668306	SPRING	1
33D	664101	HOSE-ZIPPER BAG	1
34	663404	BAG COUPLING GASKET ASSM	1
34A	663406	GASKET-BAG COUPLING	1
34B	662403	COUPLING-BAG	1
36	662102	CLIP-BAG	1
37	668305	SPRING	1
38	660630	DIRT CUP BAG ASSM	1

EXTRAS	
PART #	DESCRIPTION
660601	STANDARD PAPER BAG PACKAGE (3 BAGS)
660605	HEPA PAPER BAG PACKAGE (3 BAGS)
665102	LABEL-CRI CERTIFICATION

PERFORMANCE 128G & 128DC INTERNAL PARTS

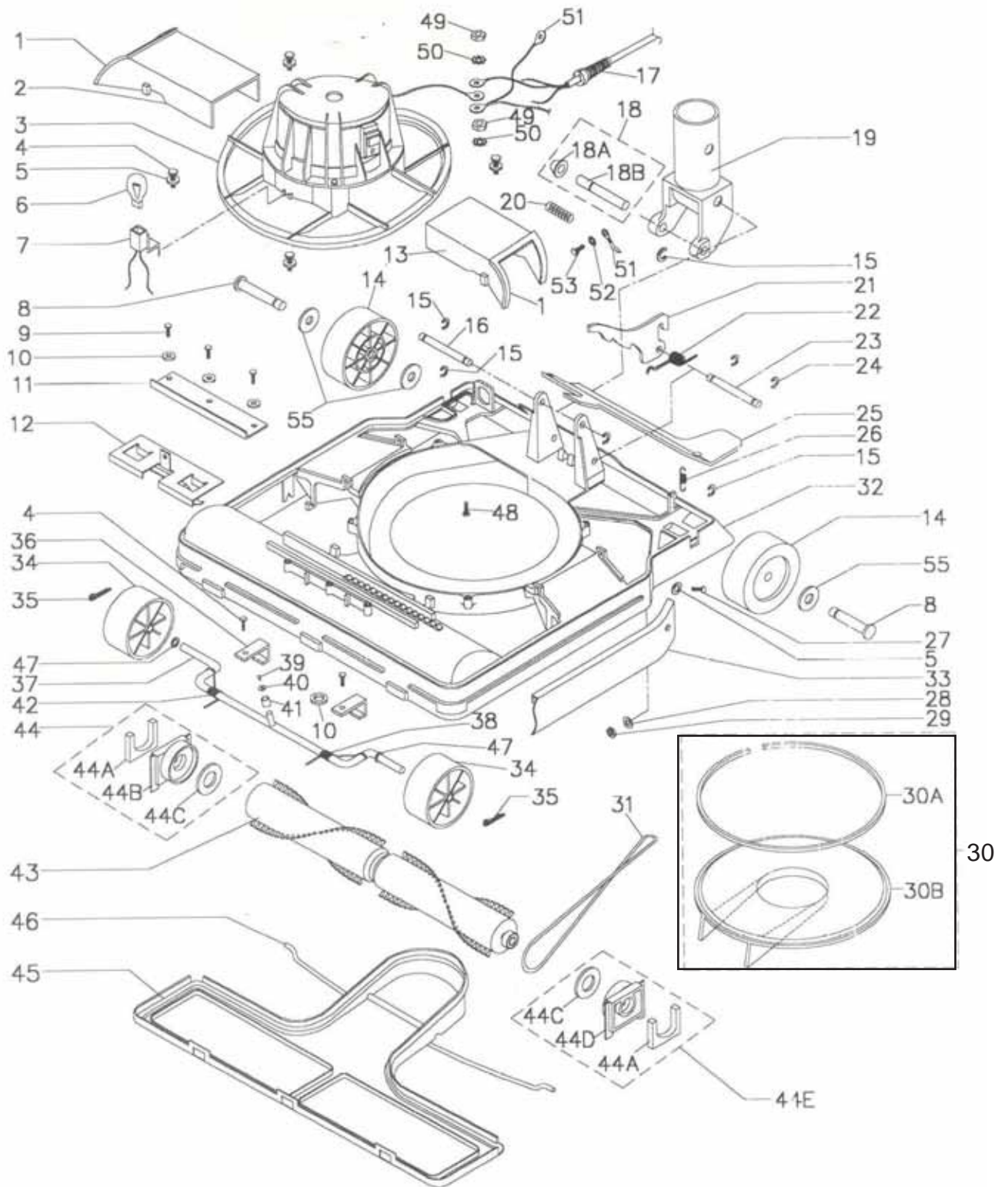

PERFORMANCE 128G & 128DC INTERNAL PARTS LIST

ITEM #	PART #	DESCRIPTION	QTY
1	663405	GASKET-AIR DUCT	1
2	662703	AIR DUCT-RIGHT	1
3	665202	MOTOR ASSM	1
4	W515D	SCREW 8-32 X 1/2	6
5	980712	WASHER-FLAT	6
6		N/A	
7		N/A	
8	667704	AXLE-REAR WHEEL	2
9	962250	SCREW 6-32 x 3/8	3
10	980710	WASHER-FLAT (02-0101)	5
11	661406	PLATE-CAM GUIDE	1
12	661405	CAM SPRING ASSM	1
13	662702	AIR DUCT-LEFT	1
14	669702	WHEEL-REAR	2
15	980708	WASHER-C PO-25	5
16	667707	SHAFT-SOCKET	1
17	663802	GROMMET	1
18	911540	SWITCH ACTUATOR ASSM	1
18A	911539	ACTUATOR-SWITCH	1
18B	667708	SHAFT-SWITCH	1
19	666801	SOCKET-TUBE	1
20	668307	SPRING	1
21	661403	CAM-HANDLE	1
22	668308	SPRING-CAM	1
23	667706	SHAFT-CAM	1
24	980707	WASHER-C	2
25	667005	PEDAL	1
26	668303	SPRING	1
27	962245	SCREW 1-32 X 1/2	2
28	980718	WASHER-STAR 10 X .204	2

ITEM #	PART #	DESCRIPTION	QTY
29	W525D	NUT 10-32	2
30	662304	COVER-FAN (NOT SOLD SEPARATELY)	1
30A	N/A	GASKET-FAN COVER	
30B	N/A	COVER-FAN	
31	903040	BELT-POLY .210 X 13 7/16-83A	1
32	664203	CHASSIS	1
33	661202	BUMPER-BLACK	1
34	667502	WHEEL-FRONT	2
35	662101	CLIP	2
36	667205	RETAINER-FRONT AXLE	2
37	660502	FRONT AXLE ASSM	1
38	668309	SPRING-FRONT AXLE	1
39	930015	RIVET-TYPE B	1
40	980709	WASHER-FLAT	1
41	661101	BUSHING	1
42	668310	SPRING-FRONT AXLE	1
43	660901	BRUSH ROLL ASSM-12"	1
45	667902	BOTTOM PLATE	1
46	667202	BAR-BOTTOM PLATE RETAINER	1
47	980711	WASHER-FLAT	2
48	962253	SCREW 8-32	1
49	W143D	NUT HEX 8-32	2
50	980717	WASHER-STAR	2
51	911538	LEAD-GROUND	1
52	980716	WASHER-STAR	1
53	962249	SCREW 6-32	1
55	980713	WASHER-FLAT 5/16 X 1/2	4
	665004	LEXAN FAN KIT (NOT SHOWN ON DIAGRAM)	
	W528D	NUT-PULLEY (NOT SHOWN ON DIAGRAM)	

WARRANTY POLICY LIMITED WARRANTY

The **Pacific** Performance Series Vacuums have been manufactured, tested and inspected in accordance with specific engineering requirements and is **WARRANTED** to be free from defects in workmanship and materials as follows:

Five (5) years parts, one (1) year labor – Chassis (128G & 128DC)

Two (2) years parts, one (1) year labor - Chassis (127G & 127DC), Fan (All), Yoke (All), Switch (All)

One (1) year parts & labor – All other components unless excluded below.

This warranty extends to the original user/purchaser and only when used, operated and maintained in accordance with **Pacific** Operating and Maintenance instructions.

This warranty does not apply to the following wear parts and accessories of the machine including:

<u>Part Number</u>	<u>Part Name</u>
660605	HEPA Paper Bags
660903	Brush Roll
660901	Brush Roll Assm.
668001	Cord Assembly
908113	Cord Assembly
903040	Belt

Nor does it apply to damage or failure caused by improper use, abuse or neglect. Warranty credit or replacement of return parts including motors, pumps, etc., is subject to incoming inspection of those items.

To secure repair under this warranty, the following procedure should be taken:

- The inoperative machine or warranted parts must be delivered to the authorized service center with shipping and delivery charges prepaid. If unable to locate a service center, you may contact **Pacific** at the address listed herein for the location of the nearest repair center or agent or for other instructions pertaining to your warranty difficulty.
- Upon compliance with the above warranty procedure, all warranted repairs would be completed at no additional charge or cost to the user.
- Only **Pacific** or its authorized dealers and agents may make no charge warranty repairs on this product. All others do so at their own risk.

This warranty limits **Pacific** liability to the repair of the product and/or warranted parts replacement and does not include incidental or consequential damages arising from the use of a **Pacific** machine whether defective or not.

This warranty is in lieu of all other expressed or implied warranties and is extended to the original purchaser/user.



PACIFIC

2259 South Sheridan Road

Muskegon, MI 49442

Phone: 231-773-1330 Fax: 231-773-1642

www.pacificfloorcare.com info@pacificfloorcare.com