



**PACIFIC**<sup>™</sup>  
F L O O R C A R E

**PURPOSE BUILT.**<sup>™</sup>

# **PARTS & OPERATING MANUAL**

## **SCE-8**

# **SELF CONTAINED EXTRACTOR**

**PLEASE READ THIS BOOK**

---

This operator's book has important information for the use and safe operation of this machine. Read this book carefully before using the machine. Keep this book and tell all operators to read the book. If you do not follow the instructions, you can cause an injury or damage equipment, furniture or buildings.

For new books, please download your copy from our website [www.pacificfloorcare.com](http://www.pacificfloorcare.com) or write to:

***Pacific Floorcare***  
*2259 S. Sheridan Drive*  
*Muskegon, MI 49442-6252*

Carefully inspect all components to ensure that there is no concealed freight damage. If such damage is discovered, file a "CONCEALED DAMAGE REPORT" immediately with the delivering carrier.

The contents of this manual are based on the latest product information available at the time of publication. Pacific reserves the right to make changes or improvements without notice.

**Thank you for purchasing a Pacific Floorcare product. Warranty registration will allow us to better serve you over the lifetime of the product. For quick and easy registration, go to:**  
**[www.pacificfloorcare.com/Register Product](http://www.pacificfloorcare.com/Register Product).**

# IMPORTANT SAFETY INSTRUCTIONS

## Grounding Instructions

This machine must be grounded. If it should malfunction or break down, grounding provides a path of least resistance for electric current to reduce the risk of electric shock. This machine is equipped with a cord having an equipment-grounding conductor and grounding plug. The plug must be inserted into an appropriate outlet that is properly installed and grounded in accordance with all local codes and ordinances.

**WARNING** - Improper connection of the equipment-grounding conductor can result in a risk of electric shock.

Check with a qualified electrician or service person if you are in doubt as to whether the outlet is properly grounded. Do not modify the plug provided with the machine. If it will not fit the outlet, have a proper outlet installed by a qualified electrician.

This machine is for use on a nominal 120-volt circuit, and has a grounded plug that looks like the plug illustrated in figure A. A temporary adapter that looks like the adapter illustrated in figures B and C may be used to connect this plug to a 2-pole receptacle as shown in figure B if a properly grounded outlet is not available. The temporary adapter should be used only until a properly grounded outlet (figure A) can be installed by a qualified electrician. The green colored rigid ear, lug, or the like extending from the adapter must be connected to a permanent ground such as a properly grounded outlet box cover. Whenever the adapter is used, it must be held in place by a metal screw.

NOTE: In Canada, the use of a temporary adapter is not permitted by the Canadian Electrical Code

## EXTENSION CORDS

Use only three-wire 12/3 or larger gauge approved extension cords that have three-prong grounding type plugs and three-pole receptacles that accept the appliance's plug. Replace or repair any damaged cords or plugs.

When servicing, refer to authorized person only. Use only identical replacement parts.

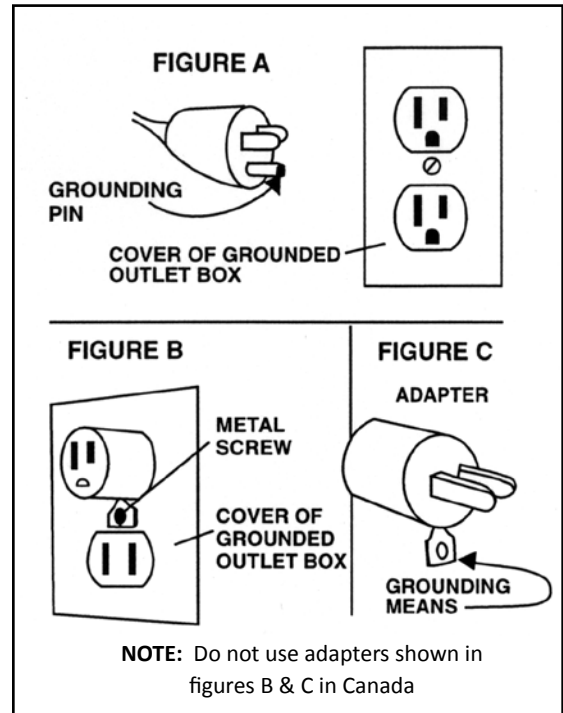

# IMPORTANT SAFETY INSTRUCTIONS

---

To ensure the safe operation of this machine, you must read and understand all warnings and instructions in this book. If you do not understand, ask your supervisor.

## READ ALL INSTRUCTIONS BEFORE USING THIS MACHINE

### **WARNING: To reduce the risk of fire, electric shock, or injury:**

1. You must be trained to operate this machine. This machine is to be operated for its intended use only.
2. Do not operate this machine unless it is completely assembled.
3. Always use a three-wire electrical system connected to the electrical ground. For maximum protection against electrical shock, use a circuit that is protected by a ground fault circuit interrupter. Consult your electrical contractor.
4. To prevent electric shock, always remove the electrical plug from the electrical outlet before doing any repairs or maintenance and when leaving the machine unattended.
5. Machines can cause an explosion when near flammable materials and vapors. Do not use this machine with or near fuels, grain dust, solvents, thinners, or other flammable materials. Do not use flammables to clean this machine.
6. A qualified or authorized person must do maintenance and repairs.
7. To prevent damage to the power cord, do not move this machine over the power cord. Always lift the power cord over the machine. Do not pull or carry cord, use cord as a handle, close a door on cord, or pull cord around sharp edges or corners. Keep cord away from heated surfaces.
8. Do not use with damaged cord or plug. If the machine is not working as it should, has been dropped, damaged, left outdoors, or dropped into water, return it to a service center.
9. Do not use this unit for dry pick-up of dust or debris.
10. To prevent injury, always remove the electrical plug from the electrical outlet before leaving the machine.
11. Do not immerse. To reduce the risk of electrical shock, use only on carpet moistened by the cleaning process. Protect the machine from rain. Keep the machine in a dry building. Always clean the machine with a clean dry cloth.
12. Make sure all switches are turned off before plugging or unplugging it power cord into/from a wall receptacle.
13. Do not use water that is hotter than 60°C (140°F).
14. To prevent damage to the solution system components do not store in freezing temperatures without proper maintenance.
15. Do not allow to be used as a toy. Close attention is necessary when used near children.
16. Do not unplug by pulling on cord. To unplug, grasp the plug, not the cord.
17. Do not handle the plug or machine with wet hands.
18. Do not put any object into openings. Do not use with any opening blocked. Keep free of dust, lint, hair and anything that may reduce the airflow.
19. Keep hair, loose clothing, fingers and all parts of body away from openings and moving parts.
20. Do not pick up anything that is burning or smoking, such as cigarettes, matches or hot ashes.
21. Use extra care when cleaning on stairs.

# OPERATING PROCEDURES

---

**WARNING! For the safe operation of this machine follow the instructions given in this booklet and the training given by your supervisor. Failure to do so can result in personal injury and/or damage to machine and property!**

**DO NOT OPERATE MACHINE IN AN EXPLOSIVE ENVIRONMENT!**

**WARNING! NEVER USE THIS MACHINE TO PICK UP VOLATILE OR EXPLOSIVE MATERIAL!**

The model shown in this manual is intended for commercial use.

## PREPARATION

1. Check power cord, plug and strain relief for worn or damaged insulation. Repair or replace if necessary.
2. Confirm the drain valve is closed (T-handle pushed down). If the valve is left open, the vacuum performance is dramatically reduced and any recovered solution will drain out.
3. The lever for the spool valve is located on the lower back panel of the machine near the left wheel. During normal operation as a self contained extractor this lever is turned toward **"CARPET SPRAY"** (vertical position). It should be turned to the **"ACCESSORY TOOLS"** position (horizontal) when a wand or other tool is being used.
4. Inspect the vacuum head and brush by tilting the machine backwards, allowing it to balance on the wheels and drain spout.
  - a) Vacuum head: Check for any damage. Burrs on the contact surface may snag carpet fibers. Gouges, scratches and chipped areas can reduce vacuum performance.
  - b) Brush: Inspect for damaged or missing bristles, replace if necessary.Return the machine to the upright position.
5. Check the inlet strainer for damage or debris. It is located at the bottom of the fresh water tank. Holes in the screen can allow contaminants to enter the pump resulting in costly repairs. A clogged screen will reduce pump performance and may cause permanent damage.
6. Remove the clear dome plate on top of the recovery tank.
  - a) Inspect for damage to the dome plate and gasket. Dirt or debris on the gasket or sealing surface of the tank can cause a vacuum leak and reduce vacuum performance.
  - b) The intake foam filter and screen at the vacuum hose connection should be clean of debris and checked periodically for any damage, replace if necessary.
  - c) Ensure that the intake filter is in its proper position to prevent recovered water from entering the vacuum motor.Return the cover to its original position on the recovery tank and connect the hoses. The suction hose that runs from the vacuum shoe to the dome connects to the right side and comes out of the rear of the machine on the right, lower side. The hose that runs from the vacuum motor to the dome that creates the suction connects to the left side of the dome.

## OPERATION

The following procedures are intended to describe and detail proper operation of your machine. Failure to follow these recommended procedures can reduce the machine's performance and may result in damage to the machine.

1. Vacuum the area to be cleaned. Your machine will do a more thorough job if the loose dirt and debris are removed before the extraction process begins.
2. Add NON-FOAMING cleaning concentrate to the fresh water/solution tank (lower tank located at the front of the machine). Follow mixing instructions for 8 gallons of water. Then fill the tank with warm to hot water. Do not use water hotter than 60°C (140°F). DO NOT OVERFILL.
3. Connect the power cord plug to a 115 volt grounded wall socket. See Grounding Instructions on page 2. Use of an extension cord is not recommended. However, if one is necessary, use only a 14-gauge or larger cord. Smaller or inferior cords are dangerous and may cause damage to your machine.
4. Turn the spool valve knob (located at the back, left of the machine) to the:
  - a) "Carpet Spray" (vertical) position for routine carpet extraction as a self contained unit, or;
  - b) Turn it in the "Accessory Tools" (horizontal) position when using a wand or tool.
5. The switch panel is located on top of the handle and contains the following:
  - a) Pump switch: Make sure in the intermittent (off) position for standard carpet extraction. The switch is only turned to the continuous (On) position for either prespraying (for which you will tilt the machine backwards slightly and run the machine back and forth over the area to be treated. All other switches should be in the Off position for prespraying) or when using an hand tool or wand after the pump direction valve has been set to "Accessory Tools" setting and the solution hose for the tool has been connected to the quick disconnect at the rear of the machine.
  - b) Turn the vacuum switch on to start the vacuum motor.
  - c) Turn the brush motor switch on to start the brush motor.

# OPERATING PROCEDURES

---

## OPERATION (continued)

7. Pull backward during operation. DO NOT ATTEMPT TO OPERATE IN A FORWARD DIRECTION. Position yourself behind the machine, grasp the handle and press the black momentary switch button near your thumbs when your hands are in the operating position. Pressing this black button activates the pump which will begin to spray out of the three jets located at the bottom of the machine near the vacuum shoe. Once you let up off this button, the pump will stop spraying. While the button is pressed in, walk slowly backward to perform the cleaning process.
8. Release the momentary switch button approximately 6 inches before completing each pass. The spray jets are located behind the vacuum head making it necessary to pull the machine a few inches further to pick up the last amount of solution dispensed onto the carpet.
9. Tilt the machine back on the rear wheels and walk forward to position the machine along side the previous pass (slightly overlapping).
10. As dirty solution is recovered, some foaming may be noted. Excessive foaming can be counteracted with liquid defoamer applied according to the chemical manufacturers directions to the inside of the recovery tank. DO NOT ALLOW FOAM TO RISE INTO OR NEAR THE DOME. THIS MAY CAUSE DAMAGE TO YOUR VACUUM MOTOR. Use defoamer or empty and flush the recovery tank.
11. To drain the recovery tank, place an empty bucket under the drain valve located on the rear of the machine. To open the drain valve, pull the T-handle up. Close the drain when the bucket is full or the recovery tank is empty. Dispose of the recovered water properly.
12. If streaking occurs after a period of operating time, this means the solution (fresh water) tank is near empty. Streaking is eliminated by adding more water and chemical solution to the tank.
13. To drain the solution tank, attach the small drain or "pump out" hose to the accessory quick connect on the back of the machine. Turn the spool valve lever to the "Accessory Tool" position. Place the open end of the hose into a bucket and turn on the pump switch to the "Continuous" (On) setting. When empty, turn off the pump switch and remove the hose from the quick connect. Also return the spool valve knob to the "Carpet Spray" position.
14. After each use clean the dome, intake filter and gasket. Do not reinstall the dome until the next use. This will allow the recovery tank to dry out.

## OPERATING WITH ACCESSORY TOOLS

1. Disconnect the machine suction (vacuum) hose from the right side (from operators position) of the recovery tank dome plate and connect the vacuum hose of hand tool/wand set to the that same port on the dome plate.
2. Connect the hand tool/wand set solution hose to the brass quick disconnect on the back, left of the machine.
3. Turn pump direction valve at the back, left of the machine to "Accessory Tools" setting.
4. Turn pump switch on control panel to "Continuous" (On) setting then begin to use your wand or hand tool.

## SERVICING

This self-contained extractor is designed and manufactured to provide years of trouble free service with a minimum of maintenance and service. The following recommendations are intended to assist the operator and Service Technician in performing routine maintenance.

Failure to follow these recommendations can result in damage to your machine and diminished performance.

**WARNING: Always unplug your machine before performing any service. Severe personal injury could result if the electrical power is not disconnected.**

### After each use:

1. Always follow through with the recommended prestart-up checks found in the Preparation section of this manual.
2. Store your machine in a dry, protected area. Do not expose this machine to rain, standing water or freezing temperatures.
3. We recommend a good thorough cleaning after each use. Clean the dome top, intake filter screen and recovery tank with fresh, clean water. Flush the fresh water tank and strainer periodically with clean water.
4. After continuous or repeated use, the jet tips and strainer/check valves will need cleaning. Unplug the cord and empty the recovery and solution tanks. Tilt the machine backward allowing it to balance on the wheels and drain valve. Remove the jets and clean with white vinegar and soft bristle brush. Remove the strainer/check valve and soak it in vinegar until visible deposits are dissolved, then scrub with a soft bristle brush.

Jet tips and strainer/check valves should be replaced once a year because they tend to erode under extended use. This can cause overuse of solution and possible streaking.

# SCE-8 SELF CONTAINED EXTRACTOR - FINAL ASSEMBLY

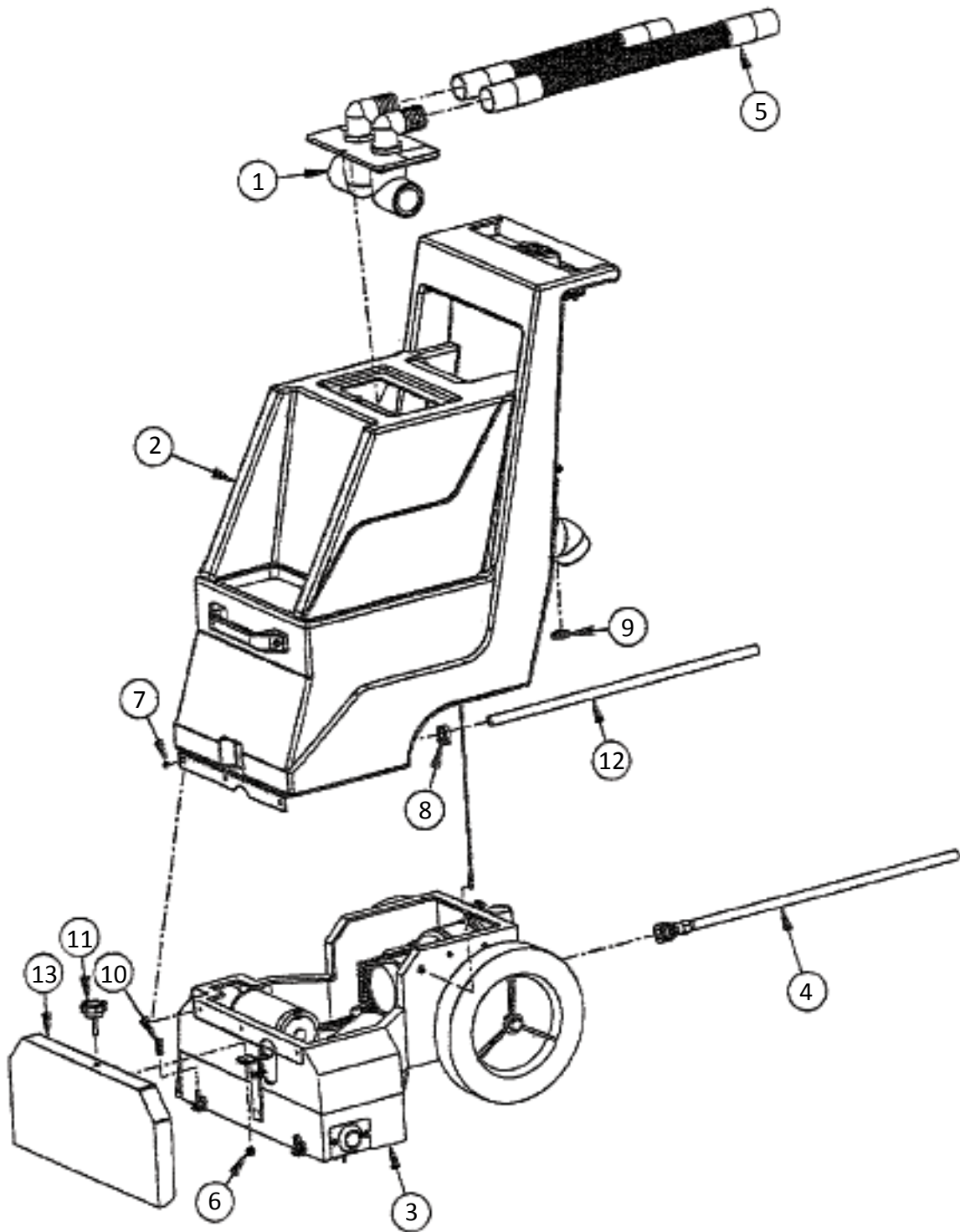

ITEM	PART NO.	DESCRIPTION	QTY.
1	252705	Dome Assembly	1
2	258684	Tank, Recovery, Blue	1
3	254215	Housing, Brush	1
4	254133	Hose, Pump Out	1
5	254128	Vacuum Hose Assm., Short	1
6	920665	Nut, Hex, 1/4, SS, Nylon	1
7	962197	Screw, 10-32 X 5/16 FH	3
8	252004	Clamp, Hose, 5/8	2
9	252005	Cable tie	1
10	258302	Spring, Vacuum Shoe	3
11	255052	Knob, Adjustable	1
12	S250P	Hose, 3/8 Push Lock	1
13	257903	Shoe, Vacuum	1

# SCE-8 SELF CONTAINED EXTRACTOR - BASE ASSEMBLY

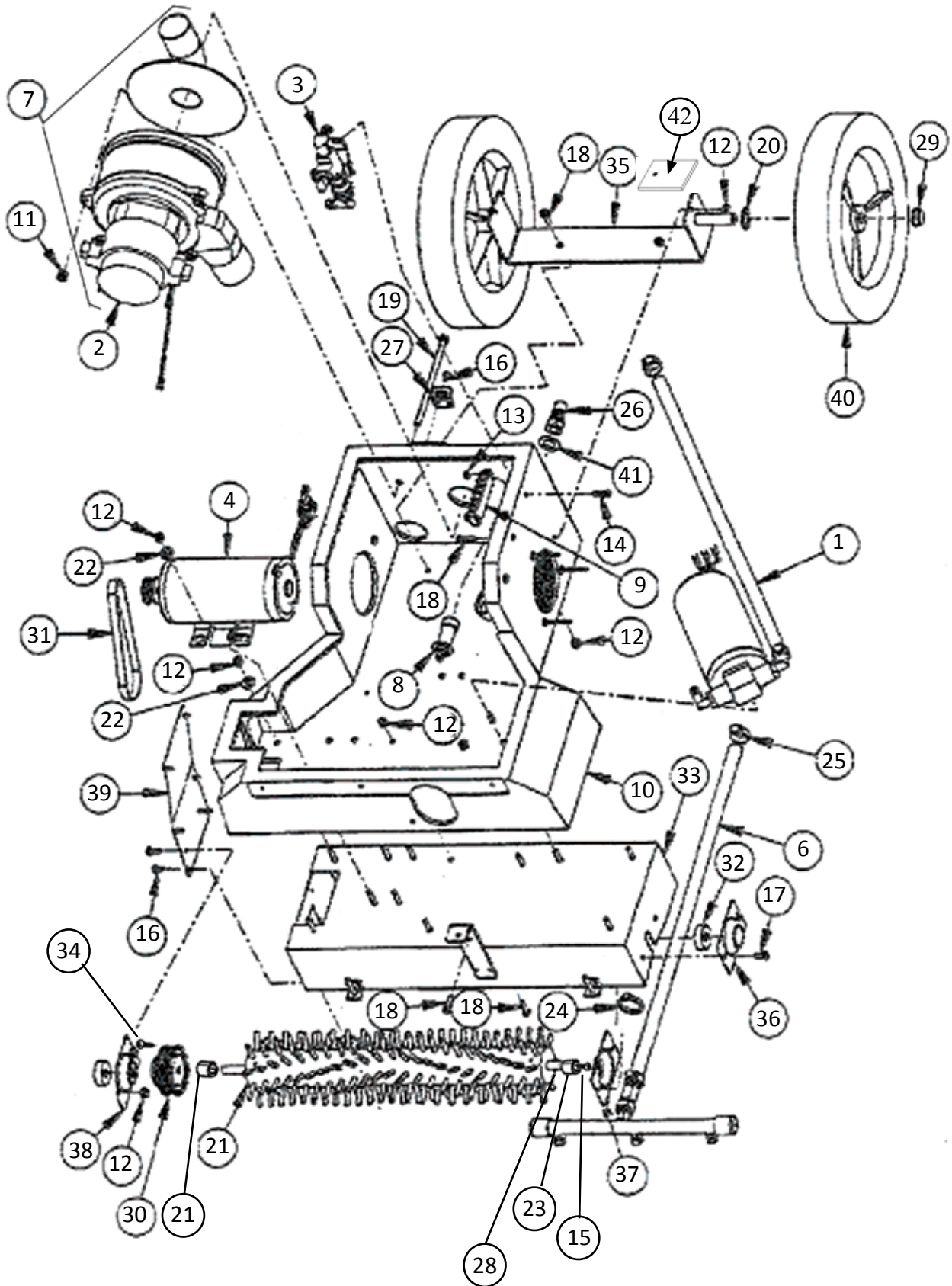



ITEM	PART NO.	DESCRIPTION	QTY.
1	257002	Pump, 60 psi, 115V	1
	257007	Pump, 100 psi, 115V	1
	217004	Pump, 60 psi, 230V	1
	257006	Pump, 100 psi, 230V	1
2	255209	Motor, Vacuum, 115V	1
	255210	Motor, Vacuum, 230V	1
3	See pg 17	Valve Assembly	
4	255250	Motor, Brush Drive, 115V	1
	255251	Motor, Brush Drive, 230V	1
	911549	Rectifier, 50A (115V Only)	1
5	250905	Brush	1
6	See pg 19	Spray Assembly	
7	255004	Kit, Vacuum & Hose Manifold	1
8	911548	Circuit Breaker, 2A	1
9	911550	Terminal Block	1
10	251302	Base	1
11	920011	Nut, 1/4-20, Elastic	3
12	920666	Nut. Hex, 10-32, SS, Nylon	18
13	W144D	Nut, 6-32, Hex w/Nylon	2
14	W132D	Screw, 6-32 X 3/4, PHP	2
15	W353D	Screw, 1/4-20 x 5/8 FH	1
16	962333	Screw, 10-32 X 5/16, PH	8
17	962363	Screw, 10-32 X 1/2	4
18	W153D2	Screw, 10-24 X 3/4, PHP	7
19	W131D	Screw, 1/4-20 X 5, HH	3
20	980078	Washer, Flat, 1/2ID X 1	2
21	3677	Bearing, Rulon Sleeve	1
22	W104D	Washer, 1/4, Flat SAE	6
23	A13084	Bearing, Rulon	1
24	911104	Tie, Cable 14.5 LG	1
25	S453P	Clamp, Hose TR 3-7/10	2
26	203302	Quick Connect-1/4 Male	1
27	258507	Strike, Latch	1
28	257700	Shaft, Brush	1
29	S482P	Cap, Snap Axle, 1/2	2
30	256900	Pulley, Brush	1
31	903045	Belt	1
32	902041	Bearing	2
33	254217	Housing, Brush	1
34	962062	Screw, 8 x 1, HILO, PHP	3
35	250803	Bracket, Axle	2
36	255005	Kit-Bearing Retainer (One Per Side)	2
37			
38	255005	Kit, Bearing Retainer	1
39	251314	Cover, Belt	1
40	259705	Wheel, 10 X 1.75	2
41	980079	Washer, 1/2ID X 1 1/4OD	1
42	258516	Shim, Tank	1

SCE-8 SELF CONTAINED EXTRACTOR - BODY ASSEMBLY

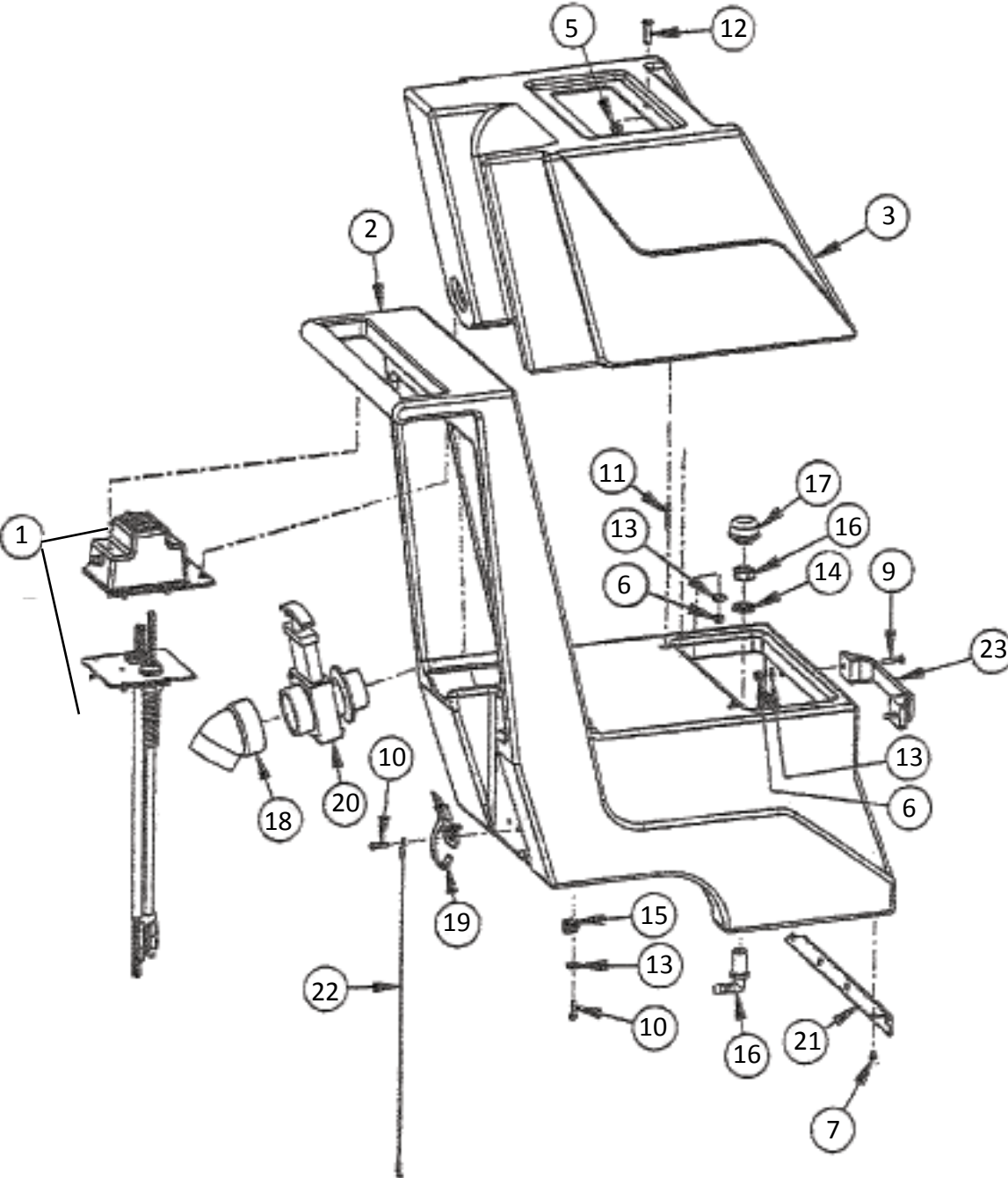

ITEM	PART NO.	DESCRIPTION	QTY.
1	See page 18	Control Box Assembly	1
2	258677	Tank, Solution	1
3	258684	Tank, Recovery	1
5	920665	Nut, Hex, 1/4, SS, Nylon	1
6	920666	Nut, Hex, 10-32, SS, Nylon	1
7	962197	Screw, 10-32 X 5/16, FH	3
9	962186	Screw, 10-32 X 1, PHP	2
10	W153D2	Screw, 10-24 X 3/4, PHP	2
11	258452	Stud, 10-32 X 1 1/4, SS	4
12	962216	Screw, 1/4-20 X 1, SS	1
13	W104D	Washer, 1/4, Flat, SAE	1
14	223344	Washer	1
15	252010	Clamp, Cable, 1/2"	1
16	211310	Body, 90 Jet w/Lock	1
17	253302	Screen, Filter	1
18	S400PB4	Elbow	1
19	252006	Clamp, Container	1
20	S400PB	Valve, Drain PVC	1
21	254554	Hinge	1
22	911552	Cable, Steel Lanyard	1
23	253901	Handle	1

# SCE-8 SELF CONTAINED EXTRACTOR - BRUSH MOTOR ASSEMBLY

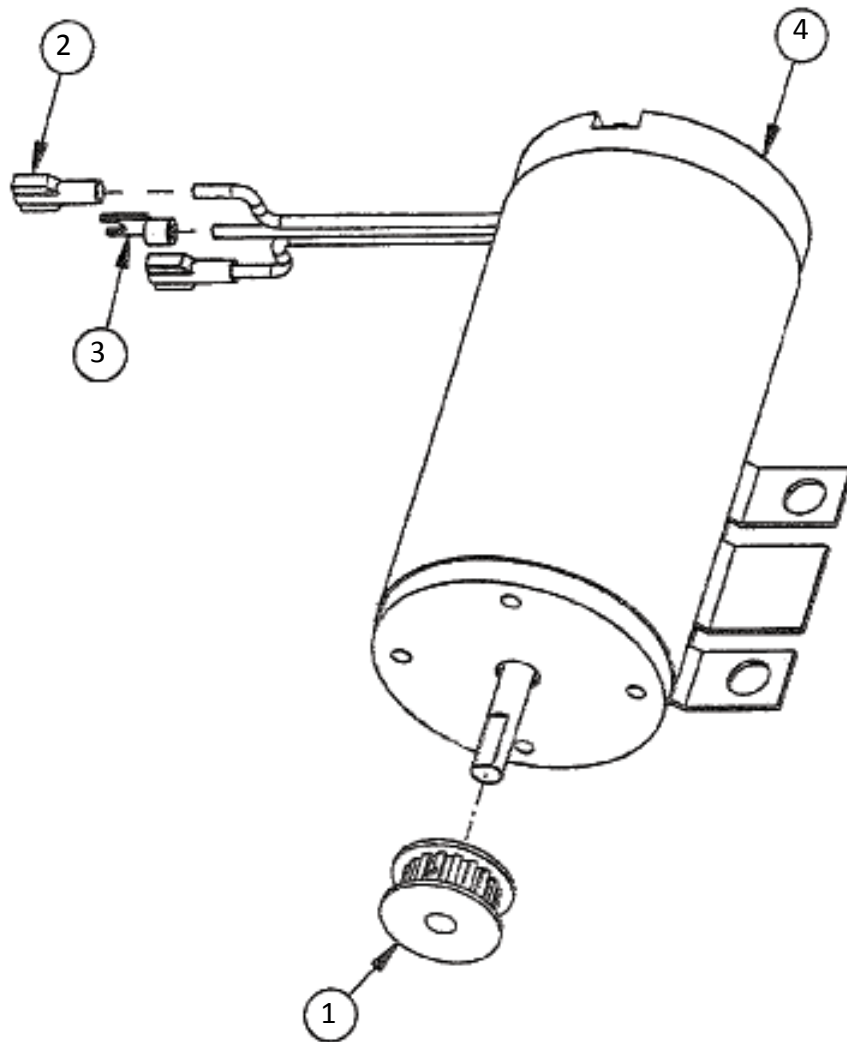

ITEM	PART NO.	DESCRIPTION	QTY.
1	256914	Pulley, 5/16, Motor	1
2	S948P	Terminal, Female	2
3	911541	Terminal, Blue, Spade	1
4	255250	Motor, Brush Drive, 115V	1
	255251	Motor, Brush Drive, 230V	1

# SCE-8 SELF CONTAINED EXTRACTOR - VACUUM MOTOR ASSEMBLY

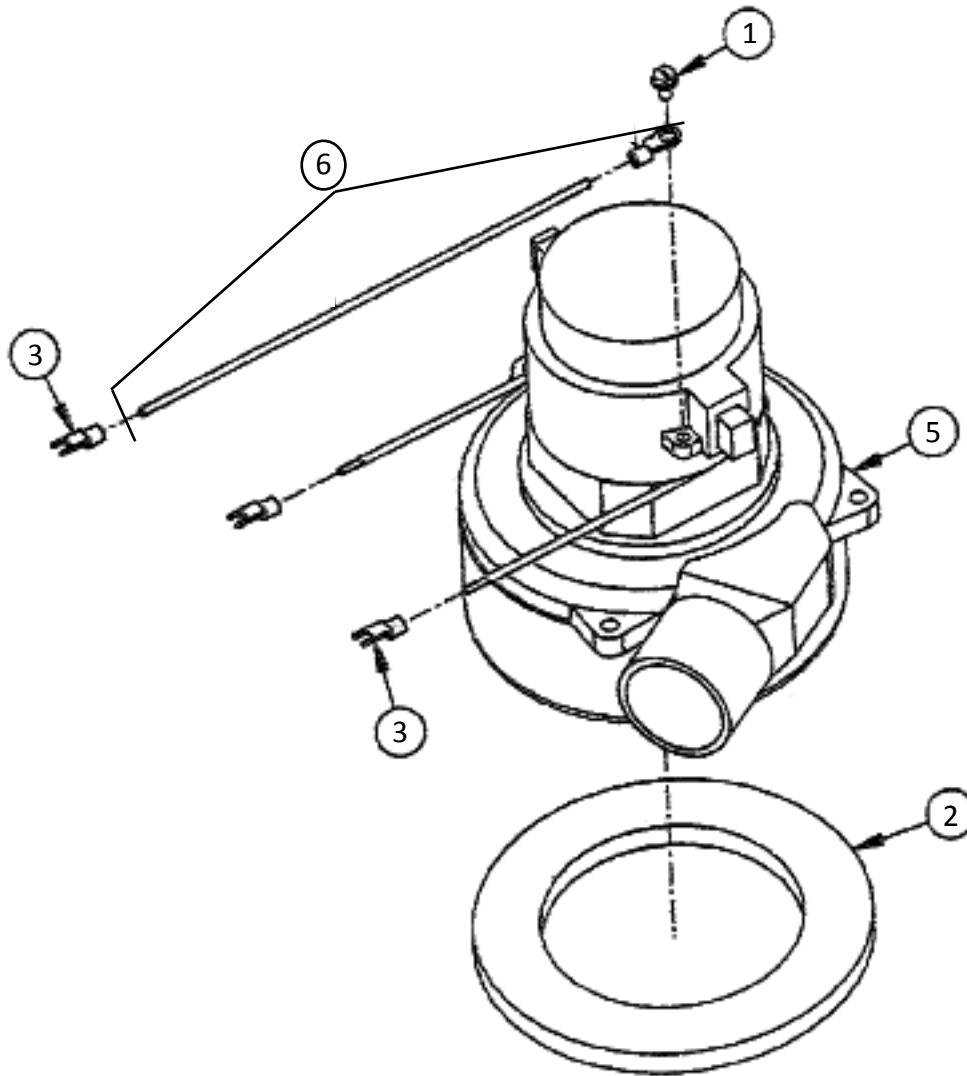

ITEM	PART NO.	DESCRIPTION	QTY.
1	962030	Screw, 10-32 X 1/2 TYPE	1
2	603473	Gasket, Top Vac	1
3	911541	Terminal, Blue, Spade	3
5	255209	Motor, Vacuum 115V	1
	255210	Motor, Vacuum 230V	1
6	911604	Lead Assm w/Ring Terminal	1

## SCE-8 SELF CONTAINED EXTRACTOR - PUMP ASSEMBLY

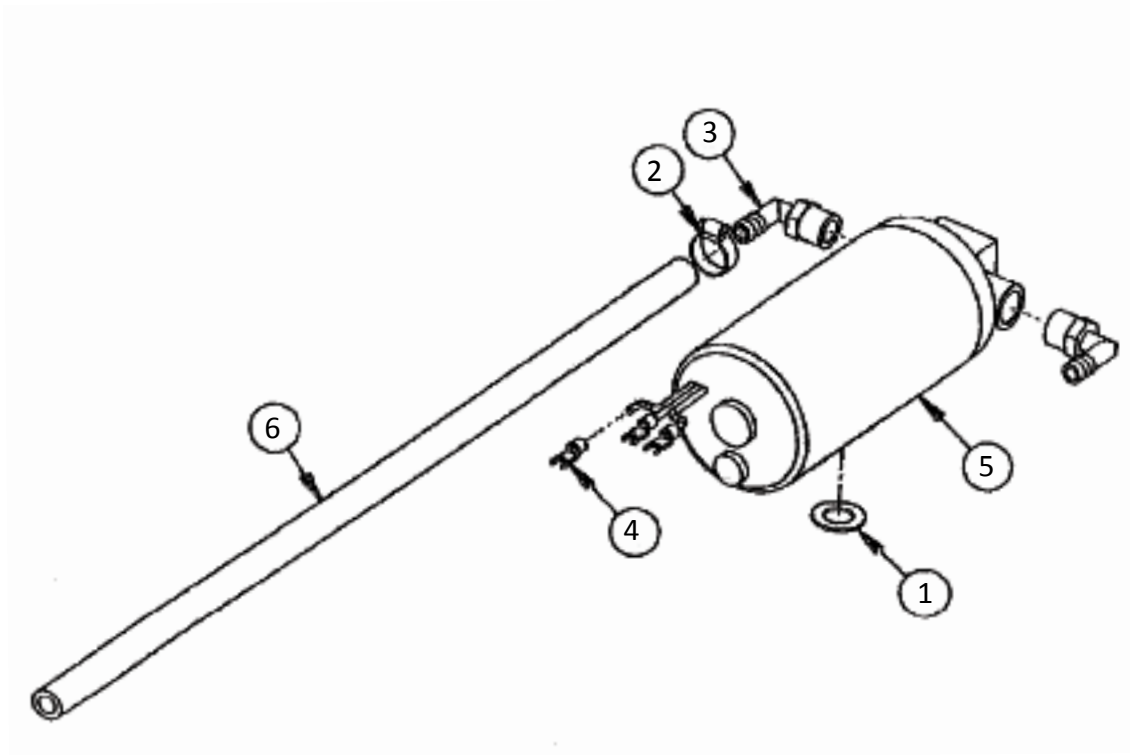

ITEM	PART NO.	DESCRIPTION	QTY.
1	980078	Washer, Flat 1/2ID X 1	2
2	202050	Clamp, Solution Hose	1
3	3765	Elbow, Male, 3/8 to 3/8	2
4	911541	Terminal, Blue, Spade	3
5	257002	Pump, 60 PSI, 115V	1
	257007	Pump, 100 PSI, 115V	1
	217004	Pump, 60 PSI, 230V	1
	257006	Pump, 100 PSI, 230V	1
6	S250P	Hose, 3/8 Push Loc	1

## SCE-8 SELF CONTAINED EXTRACTOR - VALVE ASSEMBLY

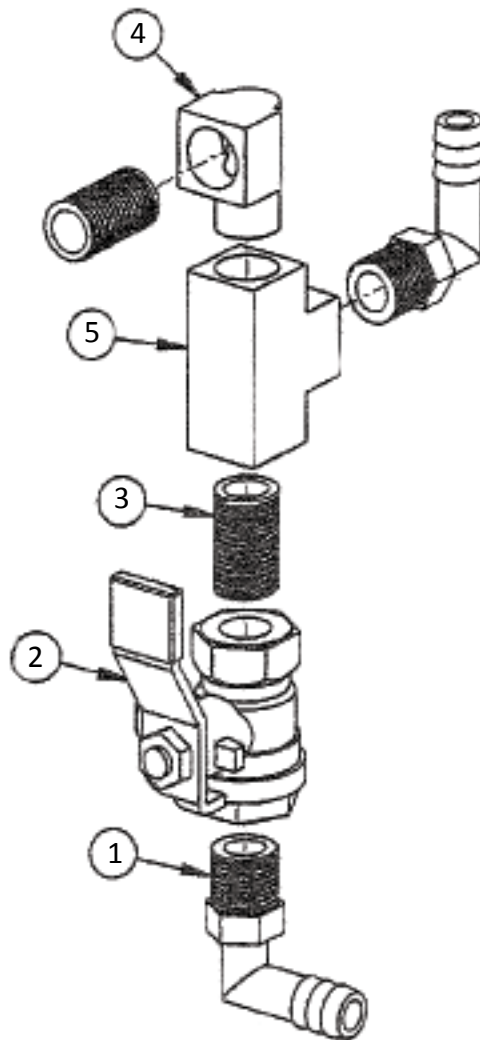

ITEM	PART NO.	DESCRIPTION	QTY.
1	3771	Elbow, Male 1/4 to 3/8	2
2	259406	Valve, Ball Brass	1
3	205752	Nipple, Close 1/4 NPT	2
4	T4027	Elbow, Brass, 90 Degree	1
5	259252	Tee, 1/4, Brass	1

## SCE-8 SELF CONTAINED EXTRACTOR - DOME ASSEMBLY

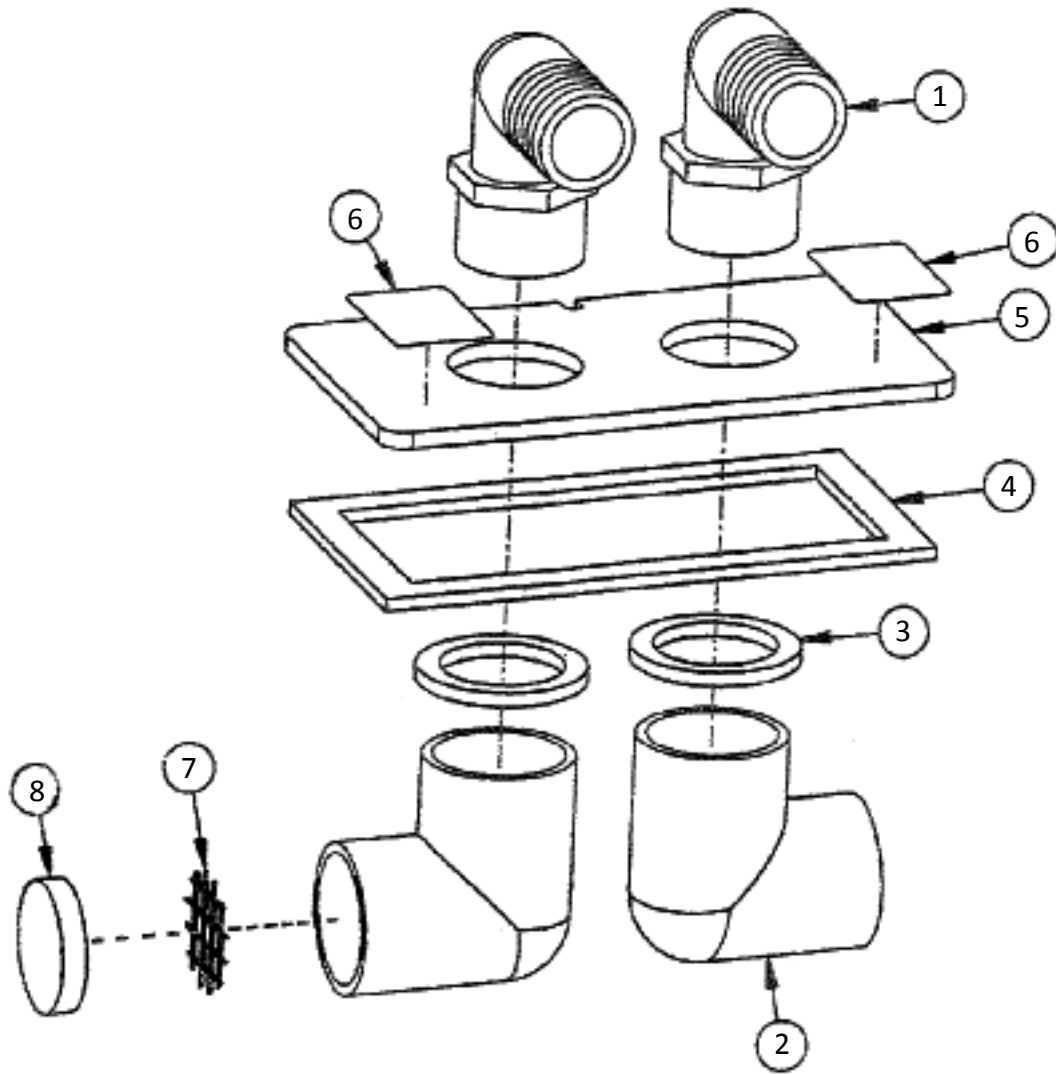

ITEM	PART NO.	DESCRIPTION	QTY.
1	252806	Elbow, 90 Degree, 1 1/2 PVC	2
2	252807	Elbow, 1 1/2, FIPTX1*	2
3	253435	Gasket, Rubber	2
4	253404	Gasket, Sponge	1
5	256604	Plate, Dome	1
6	252706	Decal, Note Clean Filter	1
	255112	Decal, Note Non Foaming	1
7	3732	Screen, Filter	1
8	253310	Filter, Foam	1
	252705	Dome Assembly	1



## SCE-8 SELF CONTAINED EXTRACTOR - SPRAY ASSEMBLY

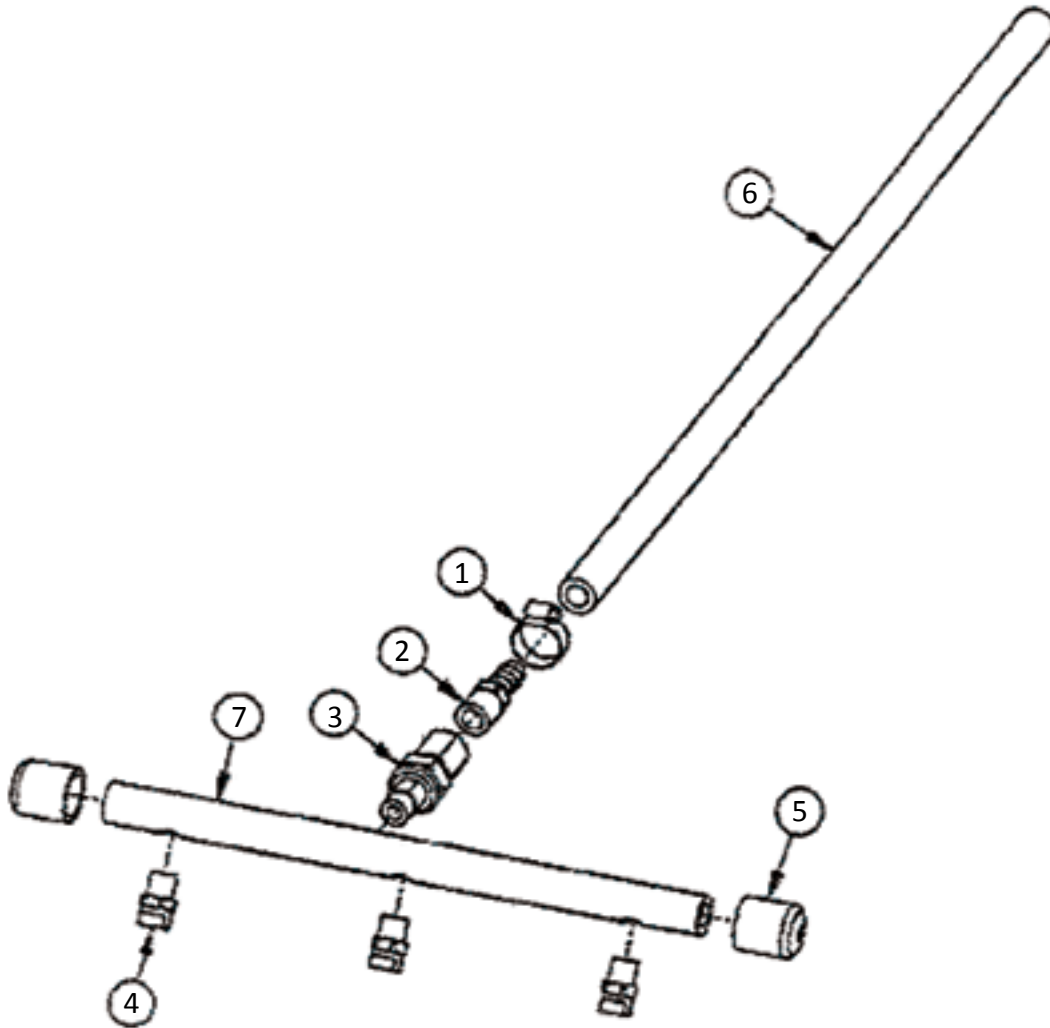

ITEM	PART NO.	DESCRIPTION	QTY.
1	S453P	Clamp, Hose	1
2	203359	Fitting, Hose Barb	1
3	S280P	Strainer w/Check Valve	1
4	254903	Jet, Spray	3
5	251503	Cap, 3/8" PVC	2
6	S250P	Hose, 3/8"	1
7	251360	Bar, Spray	1
	251363	Spray Bar Assembly	1

## SCE-8 SELF CONTAINED EXTRACTOR - CONTROL BOX ASSEMBLY

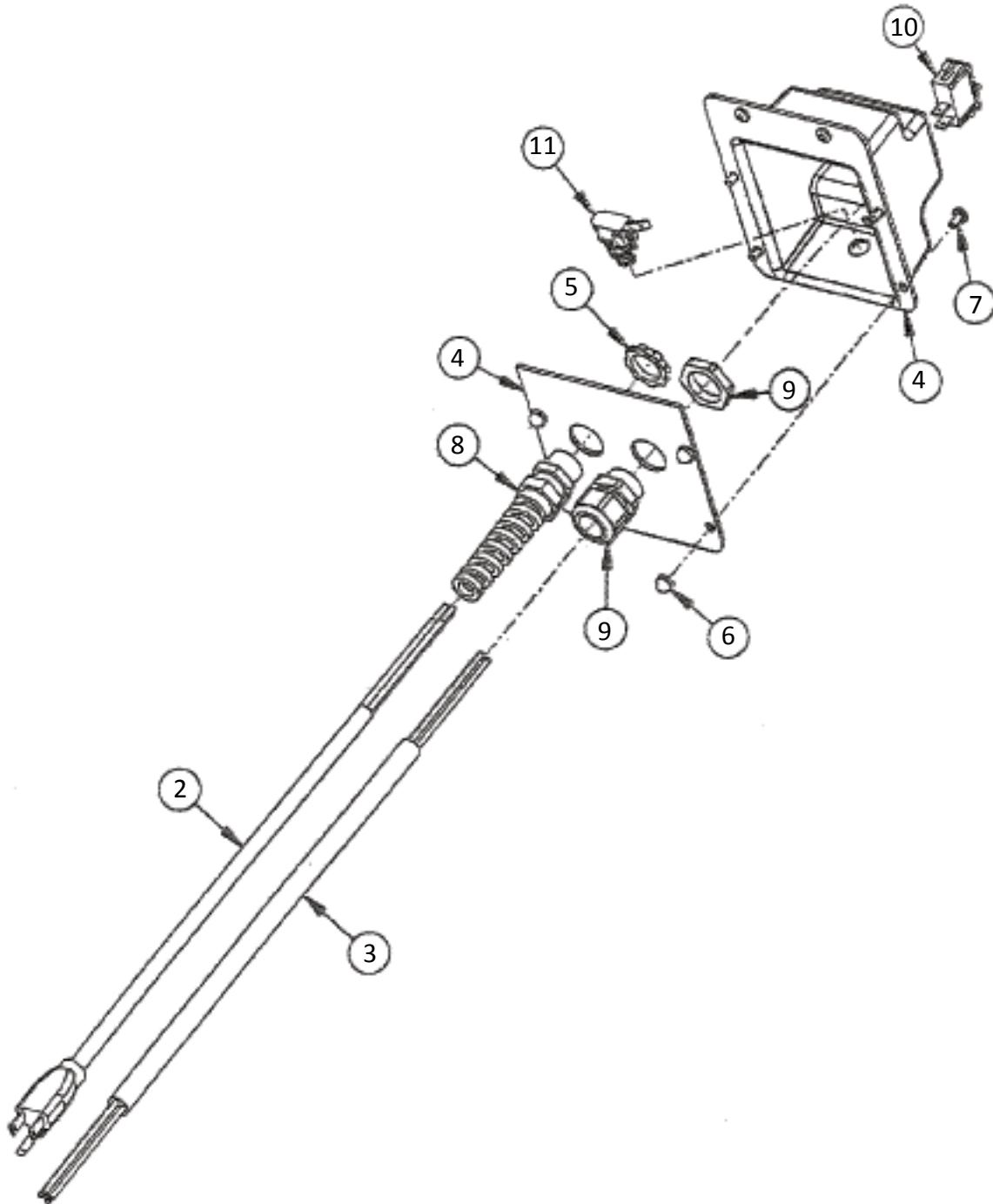

ITEM	PART NO.	DESCRIPTION	QTY
2	908104	Cord, 14-3 SJTW X 50FT	1
3	908115	Cord, Control 16/5-5	1
4	251343	Box - Control	1
	252343	Cover - Control Box (base plate)	1
5	920619	Nut, 1/2 Lock, Metal	1
6	920669	Nut, Acorn 10-32	4
7	962333	Screw, 10-32 X 5/16 PH	4
8	A13020	Relief, Strain	1
9	258511	Relief, Strain	1

ITEM	PART NO.	DESCRIPTION	QTY
10	911089	Switch, Rocker	3
11	911554	Switch, Momentary	1
12	251312	Control Box Assembly	1
	5948P	Terminal, Female	3
	911546	Terminal, Blue 16-14	2
	911541	Terminal, Blue Spade	4
	5578P	Terminal, Insulated Yellow	4
	911562	Terminal, Wire Yellow	2
	911544	Wire, 14G Black	1

# SCE-8 SELF CONTAINED EXTRACTOR - WIRING DIAGRAM

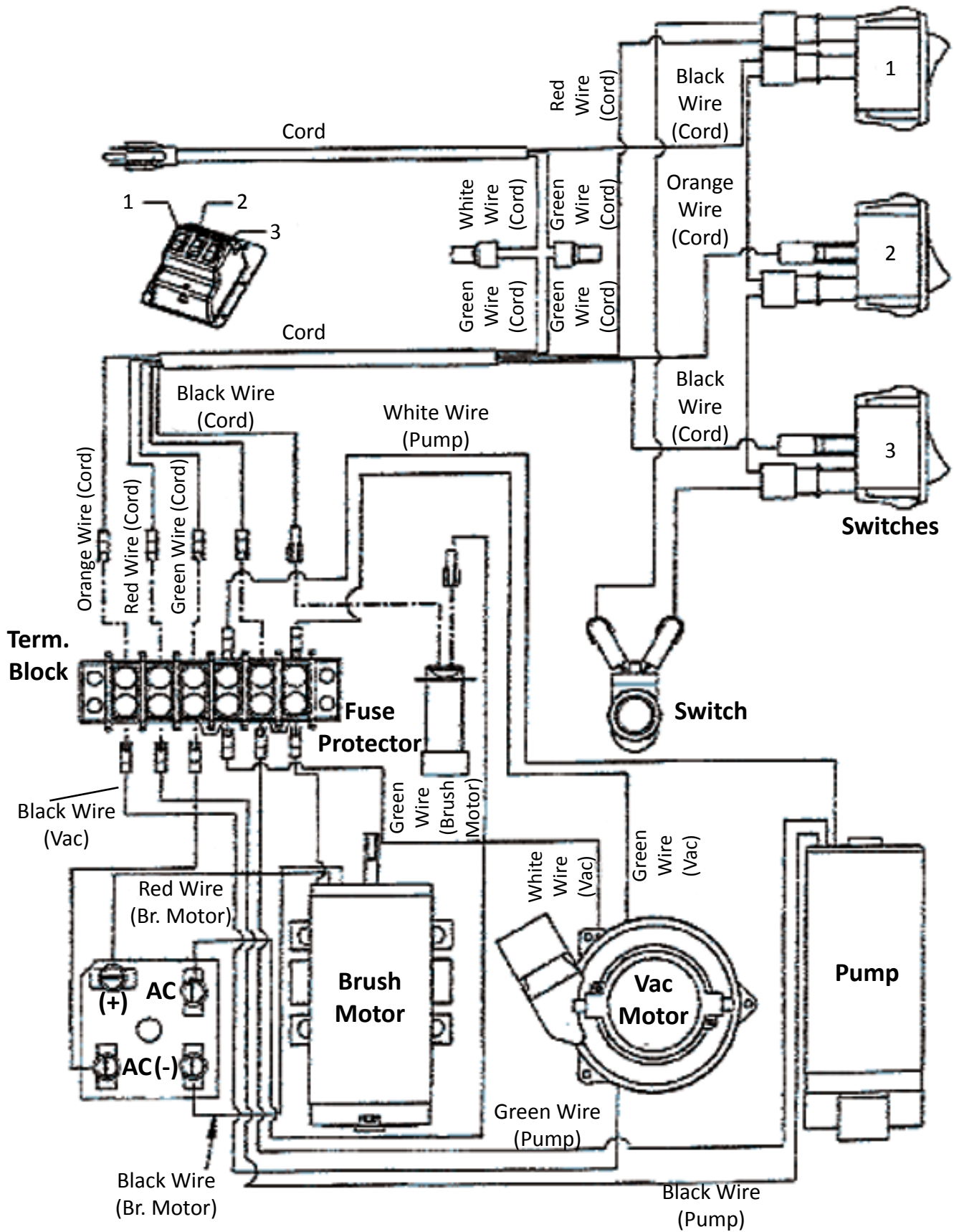

**WARRANTY POLICY**  
**EXTRACTOR, SELF CONTAINED, SCE-8**

The **Pacific Floorcare SCE-8** self contained extractors have been manufactured, tested and inspected in accordance with specific engineering requirements and are **WARRANTED** to be free from defects in workmanship and materials as follows:

Five (5) years parts, One (1) year labor - Polyethylene components

One (1) year parts and labor – All other components unless excluded below.

This warranty extends to the original user/purchaser and only when used, operated and maintained in accordance with **Pacific** Operating and Maintenance instructions.

This warranty does not apply to the following wear parts and accessories of the machine including:

<u>Part Number</u>	<u>Part Name</u>
908104	Cord Assembly
259705	Wheel
254903	Jet Tip
903045	Belt
250905	Brush
200951	Carbon Brush, 115V Motor
253302	Intake Filter
S280P	Strainer/Check Valve
254133	Drain Hose

Nor does it apply to damage or failure caused by improper use, abuse or neglect. Warranty credit or replacement of return parts including motors, etc., is subject to incoming inspection of those items.

To secure repair under this warranty, the following procedure should be taken:

- The inoperative machine or warranted parts must be delivered to the authorized dealer with shipping and delivery charges prepaid. If unable to locate the Dealer, you may contact **Pacific** at the address listed herein for the location of the nearest **Pacific** repair center or agent or for other instructions pertaining to your warranty difficulty.
- Upon compliance with the above warranty procedure, all warranted repairs would be completed at no additional charge or cost to the user.
- Only **Pacific** or its authorized dealers and agents may make no charge warranty repairs on this product. All others do so at their own risk.

This warranty limits **Pacific** liability to the repair of the product and/or warranted parts replacement and does not include incidental or consequential damages arising from the use of a **Pacific** machine whether defective or not.

This warranty is in lieu of all other expressed or implied warranties and is extended to the original purchaser/user.



**PACIFIC**<sup>™</sup>  
F L O O R C A R E

**PURPOSE BUILT.**<sup>™</sup>

2259 S. SHERIDAN DRIVE  
MUSKEGON, MICHIGAN 49442-6252  
800-968-1332  
FAX 800-863-9536