



**PACIFIC**<sup>™</sup>  
F L O O R C A R E

**PURPOSE BUILT.**<sup>™</sup>

# **PARTS & OPERATING MANUAL**

## **SPE-2.5 SPOTTER EXTRACTOR NON-HEATED**

**PLEASE READ THIS BOOK**

---

This operator's book has important information for the use and safe operation of this machine. Read this book carefully before starting the machine. Keep this book and tell all operators to read the book. If you do not follow the instructions, you can cause an injury or damage equipment, furniture or buildings.

For new books, please download your copy from our website [www.pacificfloorcare.com](http://www.pacificfloorcare.com) or write to:

***Pacific Floorcare***  
*2259 S. Sheridan Drive*  
*Muskegon, MI 49442-6252*

Carefully inspect all components to ensure that there is no concealed freight damage. If such damage is discovered, file a "CONCEALED DAMAGE REPORT" immediately with the delivering carrier.

The contents of this manual are based on the latest product information available at the time of publication. Pacific reserves the right to make changes or improvements without notice.

**Thank you for purchasing a Pacific Floorcare product. Warranty registration will allow us to better serve you over the lifetime of the product. For quick and easy registration, go to:  
[www.pacificfloorcare.com/Register Product](http://www.pacificfloorcare.com/Register Product).**

# IMPORTANT SAFETY INSTRUCTIONS

## READ AND UNDERSTAND ALL WARNINGS AND INSTRUCTIONS BEFORE USING THIS MACHINE!

### WARNING! To reduce the risk of fire, electric shock, or injury:

1. Unplug from outlet when not in use and before servicing.
2. Do not use outdoors. Protect the machine from rain.
3. Do not allow to be used as a toy. Close attention is necessary when used by or near children.
4. Use only as described in this manual.
5. Never use this machine to pick up volatile or explosive materials!
6. Do not use this machine for pick up of dust or dry debris.
7. Do not use with damaged cord or plug. If appliance should not work as it should, has been dropped or damaged, left outdoors, or dropped into water, return it to service center.
8. Do not pull or carry by cord, use cord as handle, close a door on cord or pull cord around sharp edges or corners. Do not run appliance over cord. Keep cord away from heated surfaces.
9. Do not unplug by pulling on cord. To unplug, grasp the plug, not the cord
10. Do not handle plug or appliance with wet hands. Do not immerse. Keep the machine in a dry building.
11. Do not put any objects into opening. Do not use with any opening blocked: keep free of dust, lint, hair and anything that may reduce airflow.
12. Keep hair, loose clothing, fingers and all parts of the body away from openings and moving parts.
13. Turn off all controls before unplugging.
14. Do not use in areas where flammable or combustible liquids such as gasoline may be present.
15. Connect to a properly grounded outlet only.
16. Do not use water that is hotter than 82°C (180°F).
17. To prevent damage to the solution system, do not store in freezing temperatures without proper maintenance.

## Grounding Instructions

This machine must be grounded. If it should malfunction or break down, grounding provides a path of least resistance for electric current to reduce the risk of electric shock. This machine is equipped with a cord having an equipment-grounding conductor and grounding plug. The plug must be inserted into an appropriate outlet that is properly installed and grounded in accordance with all local codes and ordinances.

**WARNING** - Improper connection of the equipment-grounding conductor can result in a risk of electric shock. Check with a qualified electrician or service person if you are in doubt as to whether the outlet is properly grounded. Do not modify the plug provided with the machine. If it will not fit the outlet, have a proper outlet installed by a qualified electrician.

This machine is for use on a nominal 120-volt circuit, and has a grounded plug that looks like the plug illustrated in figure A. A temporary adapter that looks like the adapter illustrated in figures B and C may be used to connect this plug to a 2-pole receptacle as shown in figure B if a properly grounded outlet is not available. The temporary adapter should be used only until a properly grounded outlet (figure A) can be installed by a qualified electrician. The green colored rigid ear, lug, or the like extending from the adapter must be connected to a permanent ground such as a properly grounded outlet box cover. Whenever the adapter is used, it must be held in place by a metal screw.

*NOTE: In Canada, the use of a temporary adapter is not permitted by the Canadian Electrical Code*

### EXTENSION CORDS

Use only three-wire 14/3 or larger gauge approved extension cords that have three-prong grounding type plugs and three-pole receptacles that accept the appliance's plug. Replace or repair any damaged cords or plugs.

When servicing, refer to authorized person only. Use only identical replacement parts.

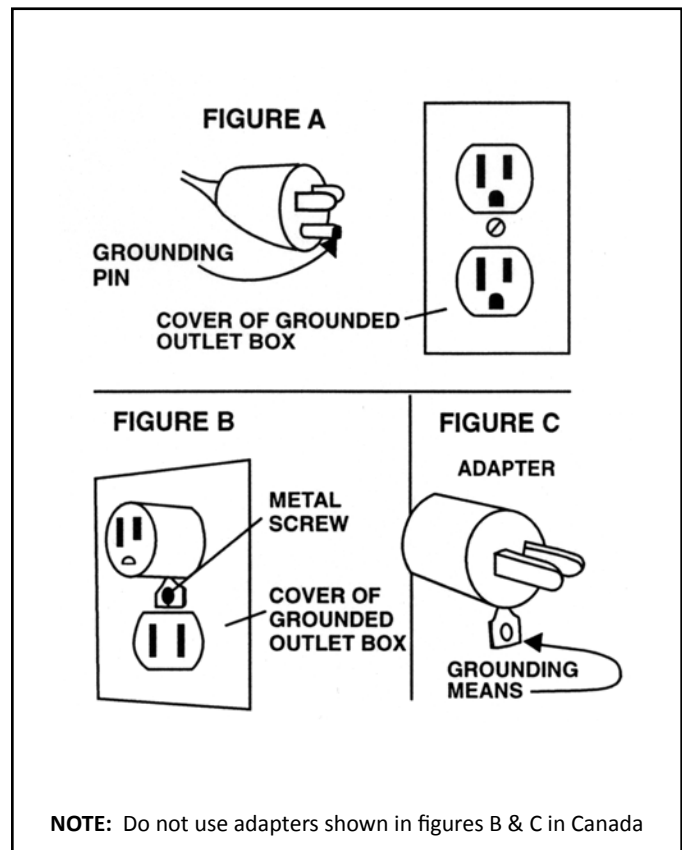

# OPERATING INSTRUCTIONS

---

**WARNING!** For the safe operation of this machine follow the instructions given in this booklet and the training given by your supervisor. Failure to do so can result in personal injury and/or damage to machine and property!

**DO NOT OPERATE MACHINE IN AN EXPLOSIVE ENVIRONMENT!**

**NEVER USE THIS MACHINE TO PICK UP VOLATILE OR EXPLOSIVE MATERIALS!**

The model shown in this manual is intended for commercial use.

## ASSEMBLY & OPERATION

1. This machine separates into two parts. The top half is the recovery tank and the lower portion is the solution tank.
2. To fill the solution tank with water you must first remove the recovery tank: release the two clamps located at the front and rear of the machine, then grasp the recovery tank handle and pull up.
3. Pour up to 2 gallons of hot water into the solution tank. **Water temperature must not exceed 140°F(60°C).** Add a non-foaming cleaning concentrate for use in extractors at the proportions noted on the container.
4. To reattach the tanks, place the recovery tank on top of the solution tank and fasten the two latches.
5. Attach the solution hose female quick connect fitting to the brass male fitting located on the side of the extractor on the base.
6. Attach the vacuum hose to the vacuum inlet port on the recovery tank.
7. Plug the power cord into a grounded wall socket.
8. Turn ON/OFF switch located at the back of the machine to the "I" position. This turns on the vacuum and the pump. Position "II" turns on only the vacuum.
9. Place hand tool on the spot and squeeze the trigger while pulling back on the hand tool.
10. The machine is equipped with a float shut-off to signal that the recovery tank needs emptying. Shut off the machine and empty the recovery tank by repeating 2-4. Rinse recovery tank out with clean water.

## DAILY OR REGULAR MAINTENANCE

1. Rinse solution and recovery tanks out after every use.
2. Twice a month, flush machine with a solution of white vinegar (one quart vinegar to two gallons of water) or anti-browning solution mixed as directed. This will prevent build up of alkaline residue in the machine.
3. If spray jet becomes clogged, remove spray tip, wash thoroughly and blow dry.

## PERIODIC MAINTENANCE

1. Periodically inspect all hoses, electrical cable and connections on the machine. Frayed or cracked hoses should be replaced to eliminate vacuum or water pressure loss. Check power cable for damage. Repair or replace damaged cord to prevent fire or electric shock.

## PROTECT FROM FREEZING

Do not allow machine to freeze with water in the solution or recovery system. To avoid damage, run pump dry before exposing to freezing temperatures.

If machine is stored for a long period of time in freezing temperatures, completely drain machine of all solution or recovered water. Pour undiluted antifreeze into the solution tank and squeeze hand tool lever until antifreeze solution is present in the solution system.

# SPE-2.5 SPOTTER EXTRACTOR, NON-HEATED, FINAL ASSEMBLY

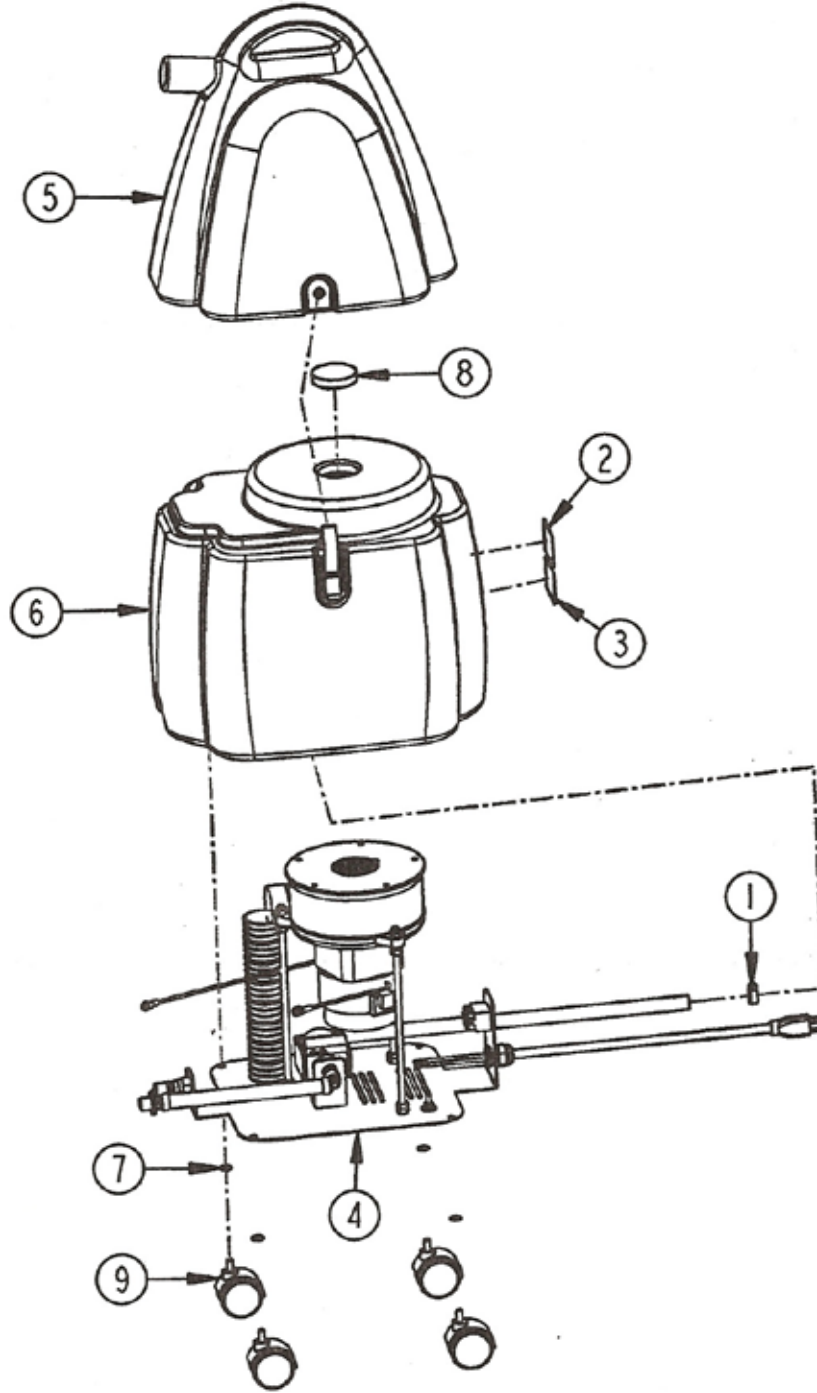

ITEM	PART NO.	DESCRIPTION	QTY.
1	202050	Clamp-1/2" Solution	4
2	252706	Decal-Clean Filter After Every Use	1
3	255112	Decal-Warning Non-Foaming	1
4	251313	Base Assembly-Complete	1
5	258682	Recovery Tank Assm-Complete	1
6	258628	Solution Tank Assm-Complete	1
7	980002	Washer-1/4 Split Lock	4
8	253310	Filter-Foam	1
9	259702	Caster-3" Diam. X .437 Stem	4

# SPE-2.5 SPOTTER EXTRACTOR, NON-HEATED, RECOVERY TANK ASSEMBLY

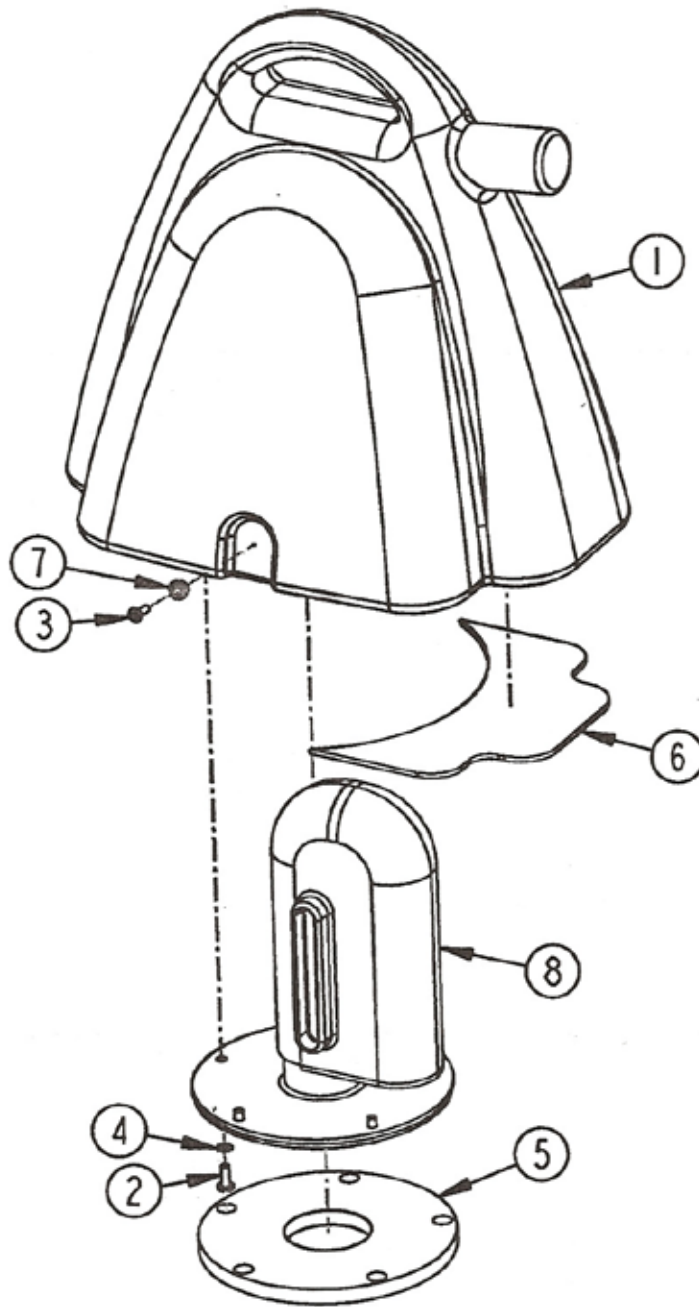

ITEM	PART NO.	DESCRIPTION	QTY.
1	258680	Recovery Tank, Blue	1
2	962002	Screw-10-32x1/2 Oval	5
3	962344	Screw-8-32x1/2 FHP Zinc	2
4	W401D	Washer-#10 Flat SAE Zinc	13
5	253442	Gasket-Vac Motor	2
6	253441	Gasket-.125 Ensolite	1
7	255120	Latch w/Keeper	2
8	253301	Ball and Float Assm-Complete	1
	258682	Recovery Tank Assm-Complete	

# SPE-2.5 SPOTTER EXTRACTOR, NON-HEATED, SOLUTION TANK ASSEMBLY

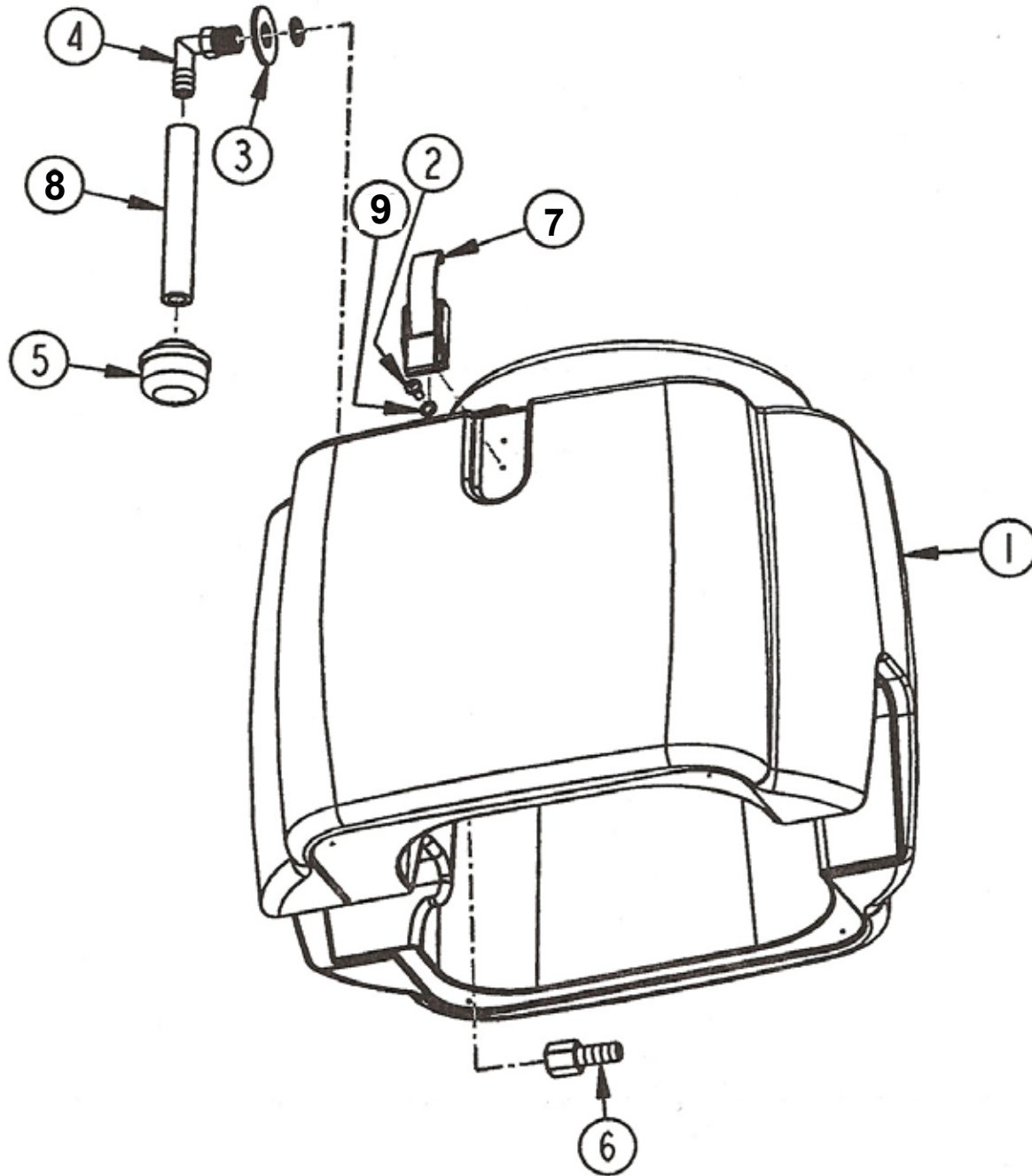

ITEM	PART NO.	DESCRIPTION	QTY.
1	258619	Solution Tank, Black	1
2	962063	Screw-8-32x3/8 PHP	4
3	980079	Washer-SS 1/2ID x 1-1/4OD	3
4	211310	Body-90 Jet w/Lock Nut	1
5	S626P	Strainer-3/8NPT SLS	1
6	253345	Fitting-Barb 3/8 x 1/4	1
7	255120	Latch w/Keeper	2
8	254134	Hose-Solution 3/8 x 3-1/4	1
9	980015	Washer-#10 Ext Tooth Shpr.	4
	258628	Solution Tank Assm-Complete	

# SPE-2.5 SPOTTER EXTRACTOR, NON-HEATED, FLOAT ASSEMBLY

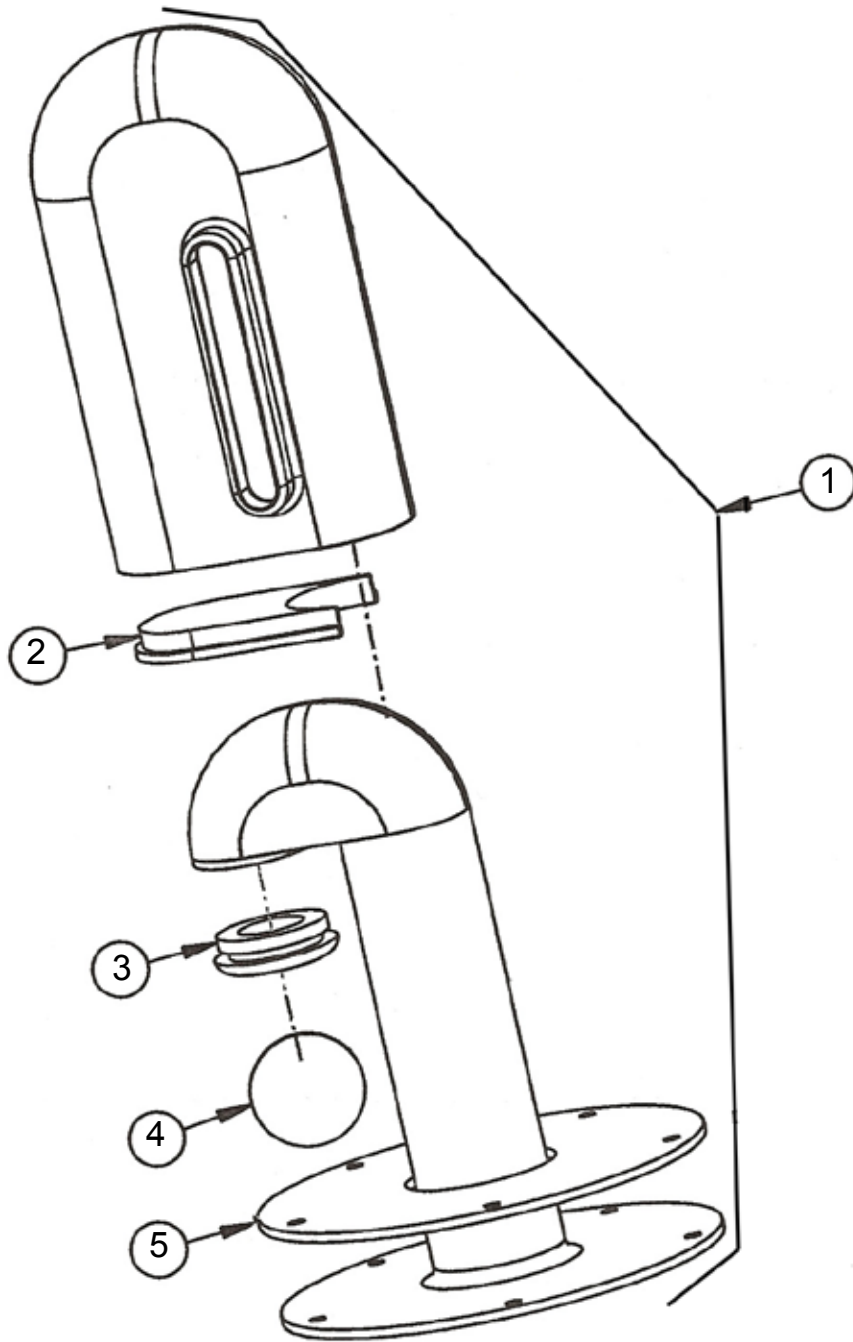

ITEM	PART NO.	DESCRIPTION	QTY.
1	253301	Ball and Float Assm-Complete	1
2	252406	Cap-Ball Float Cup	1
3	253801	Grommet-Float Shut Off	1
4	251308	Ball-Float Shut Off	1
5	253439	Gasket-.125 Ensolite	1

## SPE-2.5 SPOTTER EXTRACTOR, NON-HEATED, VACUUM ASSEMBLY

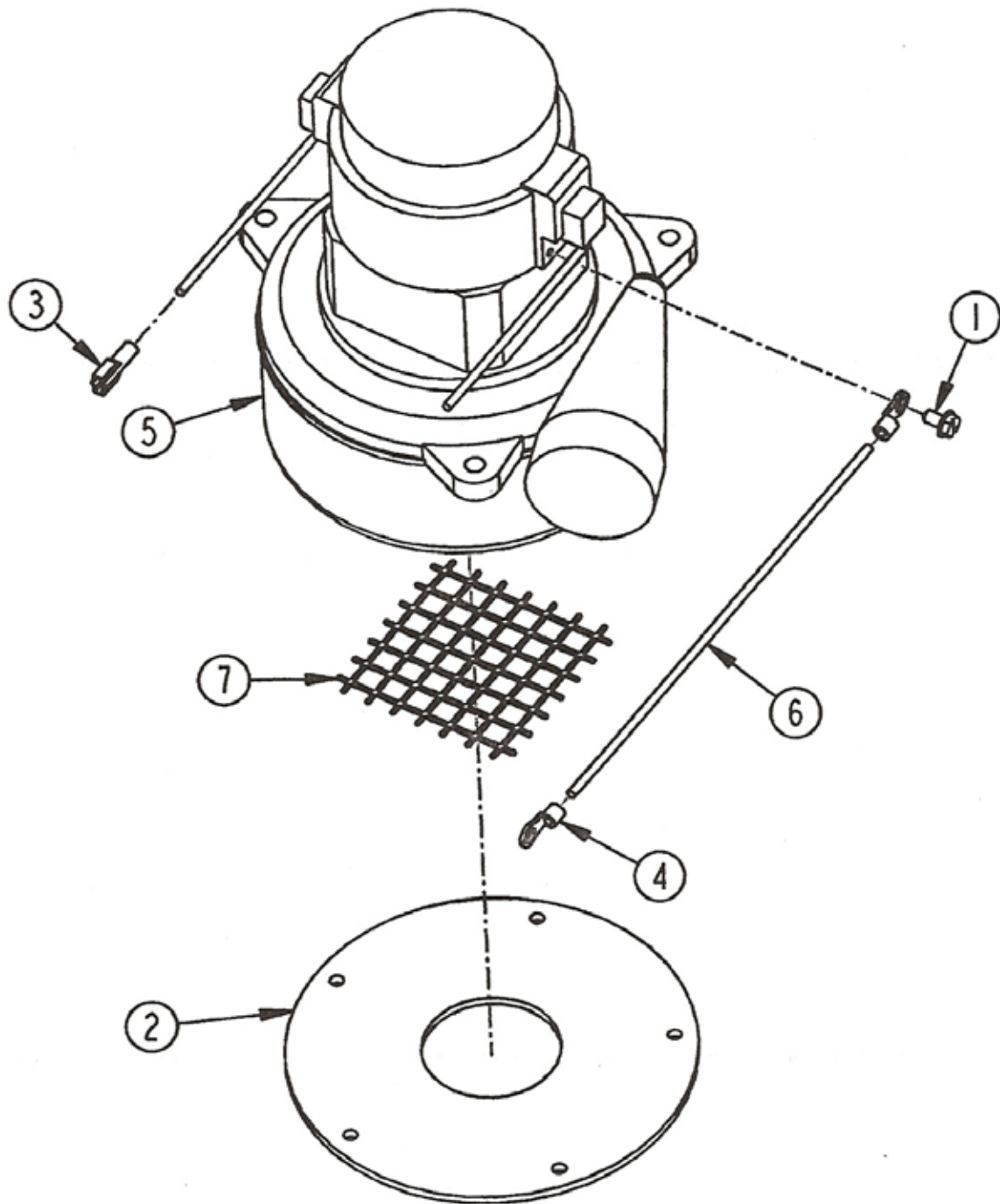

ITEM	PART NO.	DESCRIPTION	QTY.
1	962228	Screw-10 x 1/2 SMS	1
2	253442	Gasket-Vac Motor	2
3	S948P	Terminal-Female	1
4	911553	Terminal-Ring, Blue	2
5	255207	Motor-Vac-115V	1
	3738	Motor-Vac-220V	1
6	911544	Wire-14 Gauge	1
7	253302	Filter Screen	1



# SPE-2.5 SPOTTER EXTRACTOR, NON-HEATED, HAND TOOL ASSEMBLY

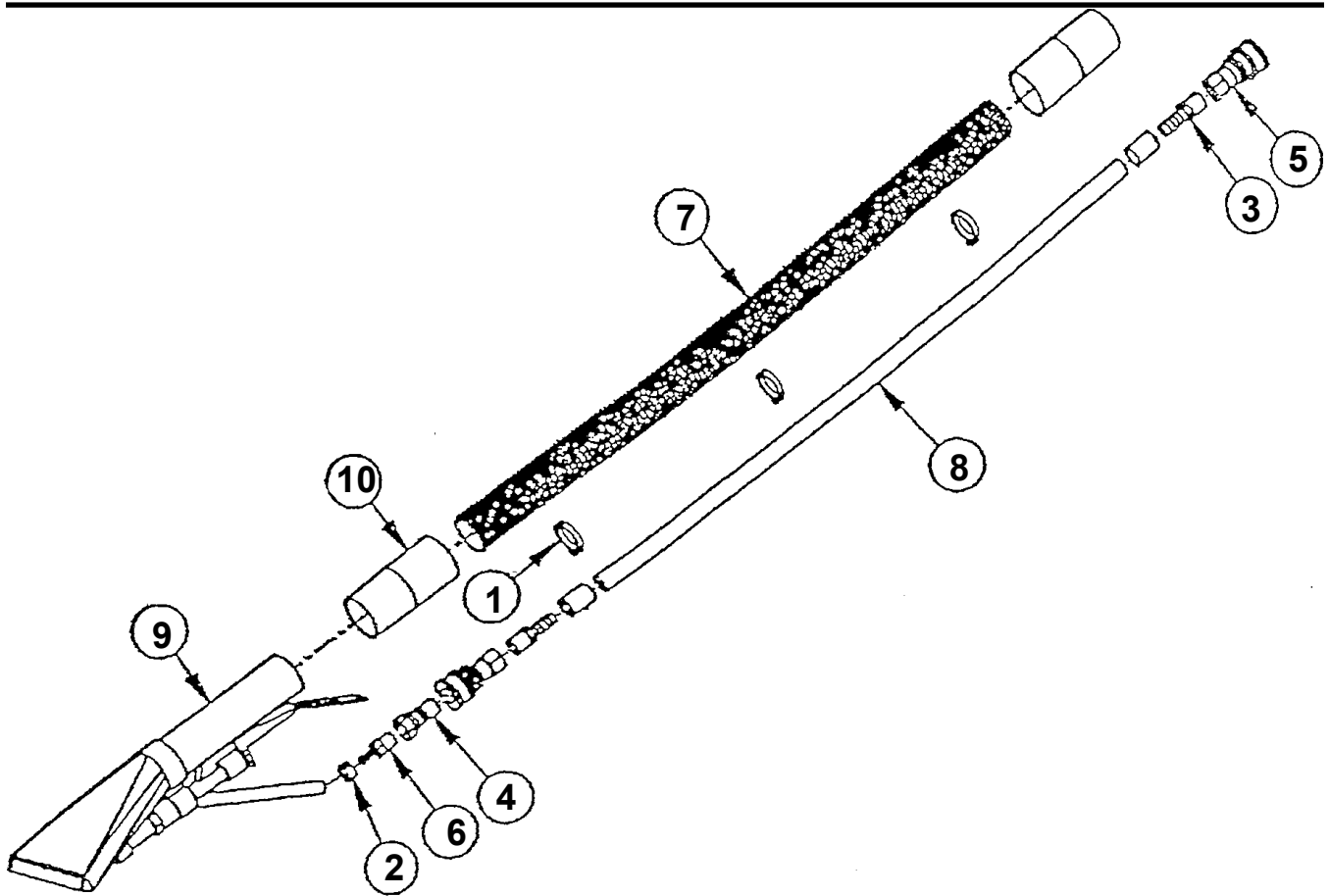

ITEM	PART NO.	DESCRIPTION	QTY.
1	911104	Tie-Cable	3
2	252008	Clamp-Oetiker 2-Ear 3/8	1
3	203359	Fitting-Hose Barb 3/8	2
4	203302	Quick Connect-Male	1
5	203308	Quick Connect-Female	2
6	253344	Fitting-Barb 3/16 x 1/4	1
7	254122	Hose-Vac 8'	1
8	254123	Hose-Solution 8'	1
9	258802	Hand Tool-4" Clear	1
10	S267P6	Cuff-Vac Hose	2
	258803	Hand Tool, 8' Vac & Sol Hose Asm	
Not Shown:			
	224901	Jet-Spray	1

**SPE-2.5 SPOTTER EXTRACTOR, NON-HEATED, BASE PLATE ASSEMBLY**

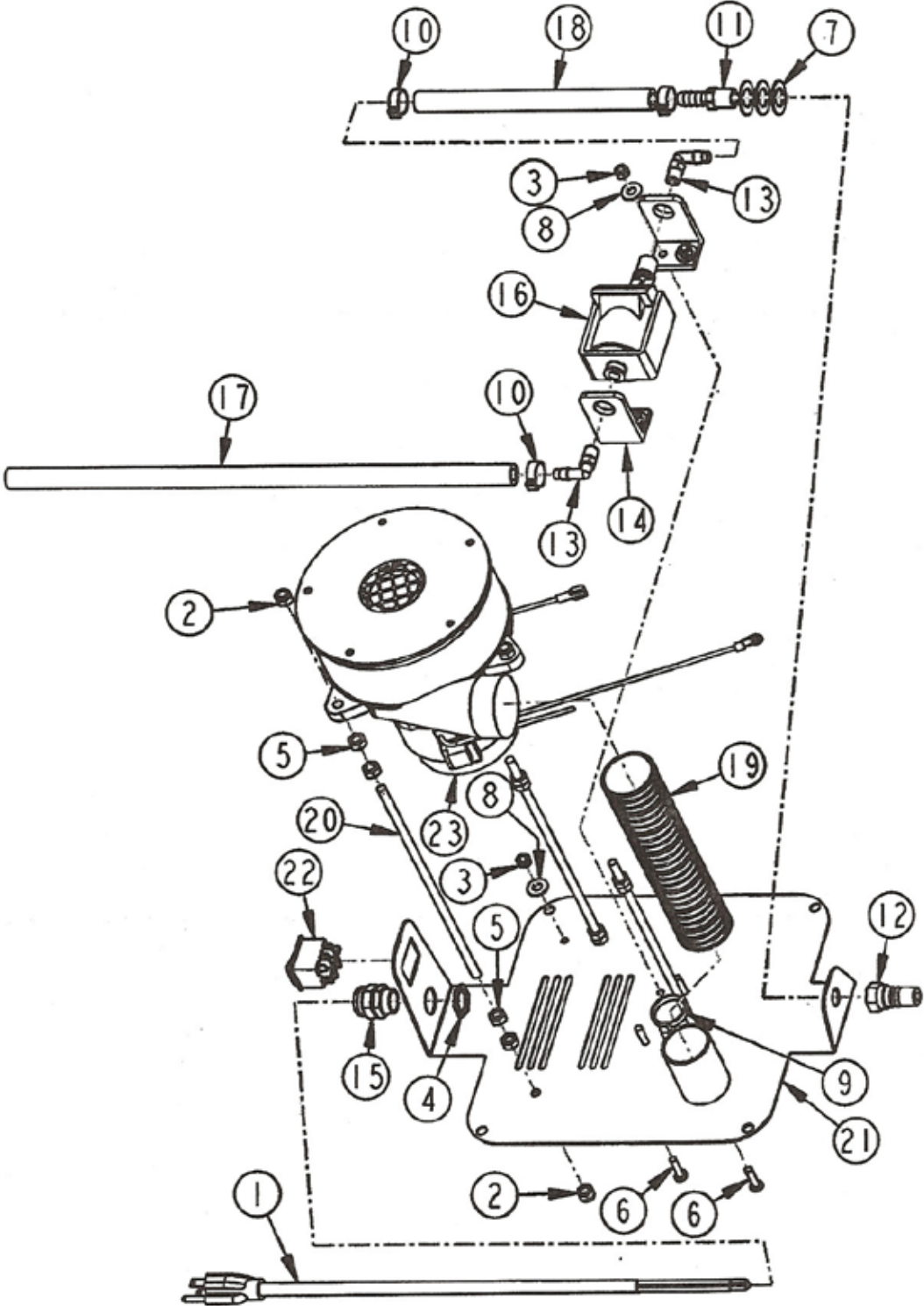

ITEM	PART NO.	DESCRIPTION	QTY.
1	908116	Cord-25' 18/3	1
2	962030	Screw-10-32 x 1/2 Type F PHP	6
3	920666	Nut-Hex 10-32 SS Nylock	5
4	980078	Washer-Flat 1/2OD x 1OD	1
5	920004	Nut-1/4-20 Hex	12
6	962003	Screw-10-32 x 3/4 PHP	5
7	(2) 980079	Washer-SS & (1) 980722 Washer-Flat	<-See
8	W401D	Washer-#10 Flat SAE Zinc	13
9	911104	Tie-Cable 14.5 LG	1
10	S453P	Clamp-Hose	1
11	203359	Fitting-Hose Barb	1
12	203302	Quick Connect-1/4 Male	1
13	252813	Elbow-Male 1/8 to 3/8 Barb	2
14	250808	Bracket-L Pump	1
15	258506	Strain Relief	1
16	257003	Pump-115V	1
	217004	Pump-220V	1
17	254124	Hose-3/8 x 13"	1
18	254125	Hose-3/8 x 7.5"	1
19	259001	Tube-Clear 1-1/2" w/ Wire	1
20	257404	Rod-Threaded 1/4-20 x 3'	3
21	256602	Plate-Base	1
22	911597	Switch-Rocker	1
23	255207	Motor-Vac-115V	1
	3738	Motor-Vac-220V	1

# SPE-2.5 SPOTTER EXTRACTOR, NON-HEATED, WIRING DIAGRAM

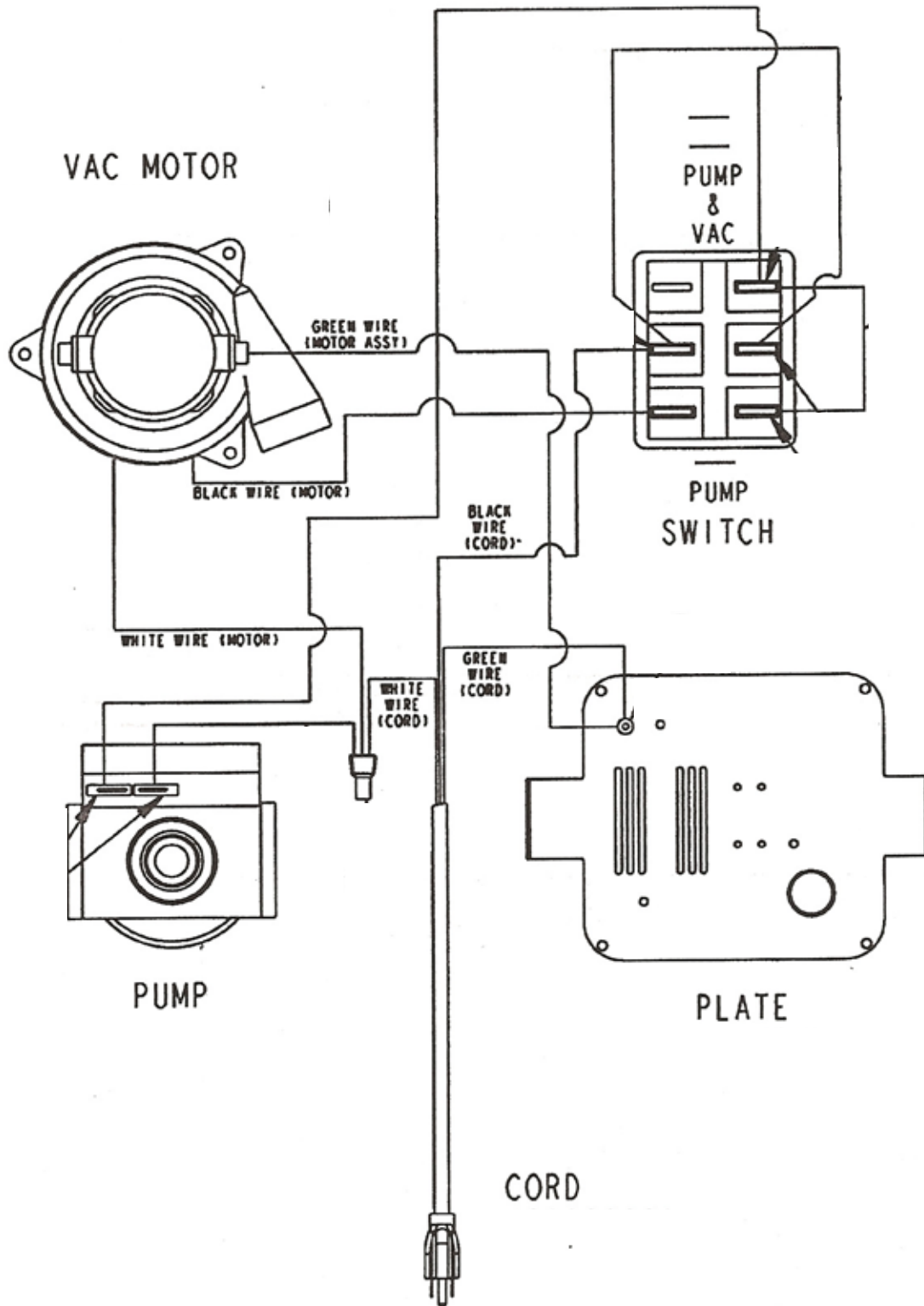

**WARRANTY POLICY**  
**SPOTTER EXTRACTOR, MODEL SPE-2.5, NON-HEATED**

The **Pacific Floorcare SPE-2.5** Spotter Extractor has been manufactured, tested and inspected in accordance with specific engineering requirements and is **WARRANTED** to be free from defects in workmanship and materials as follows:

One (1) year parts and labor – All other components unless excluded below.

This warranty extends to the original user/purchaser and only when used, operated and maintained in accordance with **Pacific** Operating and Maintenance instructions.

This warranty does not apply to the following wear parts and accessories of the machine including:

<u>Part Number</u>	<u>Part Name</u>
908116	Cord Assembly Carbon Brushes, 115V
254122	Vacuum Hose
254123	Solution Hose

Nor does it apply to damage or failure caused by improper use, abuse or neglect. Warranty credit or replacement of return parts including motors, etc., is subject to incoming inspection of those items.

To secure repair under this warranty, the following procedure should be taken:

- The inoperative machine or warranted parts must be delivered to the authorized dealer with shipping and delivery charges prepaid. If unable to locate the Dealer, you may contact **Pacific** at the address listed herein for the location of the nearest **Pacific** repair center or agent or for other instructions pertaining to your warranty difficulty.
- Upon compliance with the above warranty procedure, all warranted repairs would be completed at no additional charge or cost to the user.
- Only **Pacific** or its authorized dealers and agents may make no charge warranty repairs on this product. All others do so at their own risk.

This warranty limits **Pacific** liability to the repair of the product and/or warranted parts replacement and does not include incidental or consequential damages arising from the use of a **Pacific** machine whether defective or not.

This warranty is in lieu of all other expressed or implied warranties and is extended to the original purchaser/user.



**PACIFIC**<sup>™</sup>  
F L O O R C A R E

**PURPOSE BUILT.**<sup>™</sup>

2259 S. SHERIDAN DRIVE  
MUSKEGON, MICHIGAN 49442-6252  
800-968-1332

FAX 800-863-9536