

# ScrubMaster 20B, 20BT and FloorMaster 18B Models 20Bc

## Parts List & Service Manual

The contents of this manual are based on the latest product information available at the time of publication. Pacific Steamex reserves the right to make changes or improvements to its machines without notice.

For new books write to:

*Pacific*

2259 S. Sheridan

Muskegon, MI 49442-6252

Carefully inspect all components to ensure that there is no concealed freight damage. If such damage is discovered, file a "CONCEALED DAMAGE REPORT" immediately with the delivering carrier.

FOR YOUR CONVENIENCE, RECORD THE FOLLOWING  
IMPORTANT INFORMATION:

MODEL \_\_\_\_\_

SERIAL NUMBER \_\_\_\_\_

PART NUMBER \_\_\_\_\_

DATE PURCHASED \_\_\_\_\_

# NUMERALS

6740619D

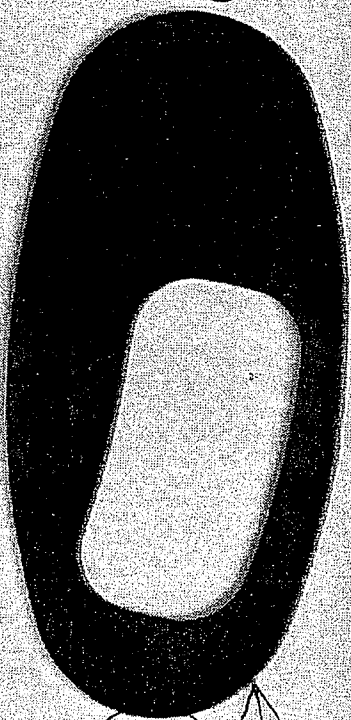

210

NUMERALS CHARACTERS - Foam

67406200

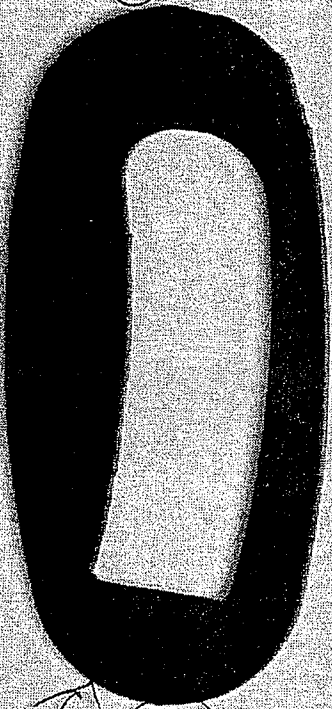

208

ORIGINAL - RUBBER

2000 3 2

## TABLE OF CONTENTS

MACHINE DRAWINGS & PARTS LISTS .....	PAGES 4 - 27
20B & FLOORMASTER 18B ELECTRICAL SCHEMATICS & PARTS LISTS .....	PAGES 28 - 31
ELECTRICAL SCHEMATICS & PARTS LISTS - 20BT & FLOORMASTER TRACTION MODELS .....	PAGES 32 - 34
ADJUSTMENTS & INSPECTIONS .....	PAGES 35 - 39
WARRANTY .....	PAGE 40

# CYLINDRICAL BRUSH ASSEMBLY FloorMaster 20 BC

885622 Manual Insert

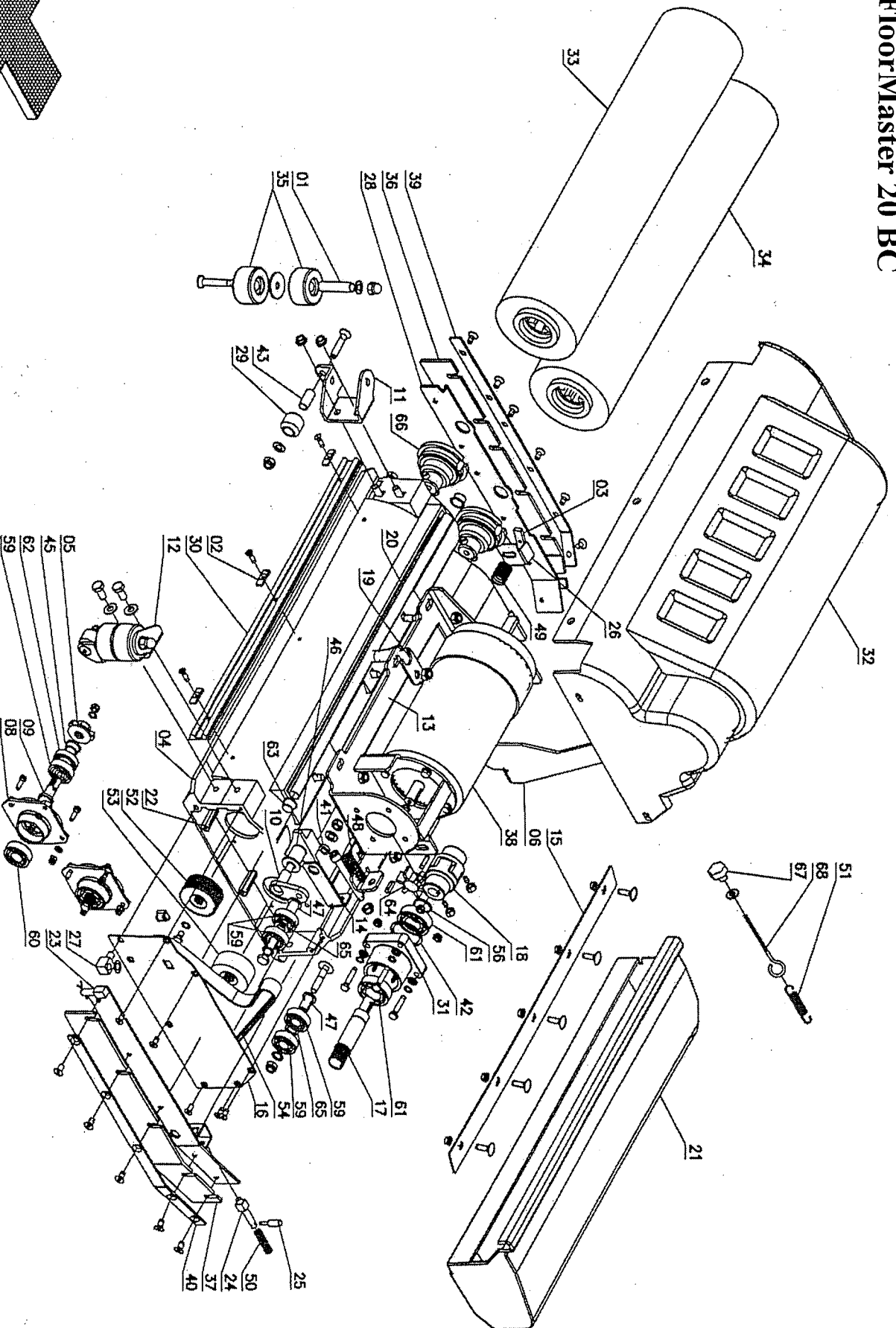

## FloorMaster 20 BC CYLINDRICAL BRUSH ASSEMBLY

Item	Part Number	Description	Qty.
1	40707140	Pipe	2
2	41646240	Plaque	3
3	42103120	Wing Nut	1
4	42307200	Tunnel	1
5	42307210	Left Hub	2
6	42303070	Support	1
8	42307240	Bearing Support	2
9	42307250	Shaft Left	2
10	42307260	Arm	1
11	42307270	Support Wheels	1
12	42307280	Support Wheels	1
13	42307290	Motor Support	1
14	42307300	Tie Rod	1
15	42307310	Blade	1
16	42307320	Cover	1
17	42307330	Shaft	1
18	42307340	Hub	2
19	42307350	Stop	1
20	42307360	Pipe	1
21	42307370	Hopper	1
22	42307380	Stud Bolt	2
23	42307390	Support	1
24	42307400	Pin	1
25	42307410	Pin	1
26	42307420	Lever	1
27	42307430	Coupling	1
28	42307440	Support	1
29	42307450	Wheel	2
30	42307470	Bumper	1
31	42317010	Support	1
32	42346130	Cover	1
33	66823170	Front Brush	1

Item	Part Number	Description	Qty.
34	66823180	Rear Brush	1
35	67020010	Wheel	4
36	67623030	Splash Guard	1
37	67623040	Splash Guard	1
38	68220420	Motor	1
39	68823010	Right Blade	1
40	68823020	Left Blade	1
41	69022040	Spacer	1
42	69022050	Spacer	1
43	69102110	Bushing	2
45	69122060	Bushing	2
46	69122070	Bushing	1
47	69122080	Bushing	2
48	69210040	Spring	1
49	69210700	Spring	1
50	69210710	Spring	1
51	69220160	Spring	1
52	69420300	Pulley	1
53	69430210	Pulley	1
54	70130008	Belt	1
56	70220012	Seeger Ring	1
59	902019	Bearing	8
60	902032	Bearing	2
61	70512002	Bearing	2
62	70717321	Oil Seal	4
63	72913006	Cover	2
64	74807004	Rubber Coupling	1
65	71112008	Washer - Brass	2
66	A2307003	Right Hub Assembly	2
67	74006004	Knob	1
68	42307150	Hook	1

CYLINDRICAL BRUSH ASSEMBLY  
18B

01A

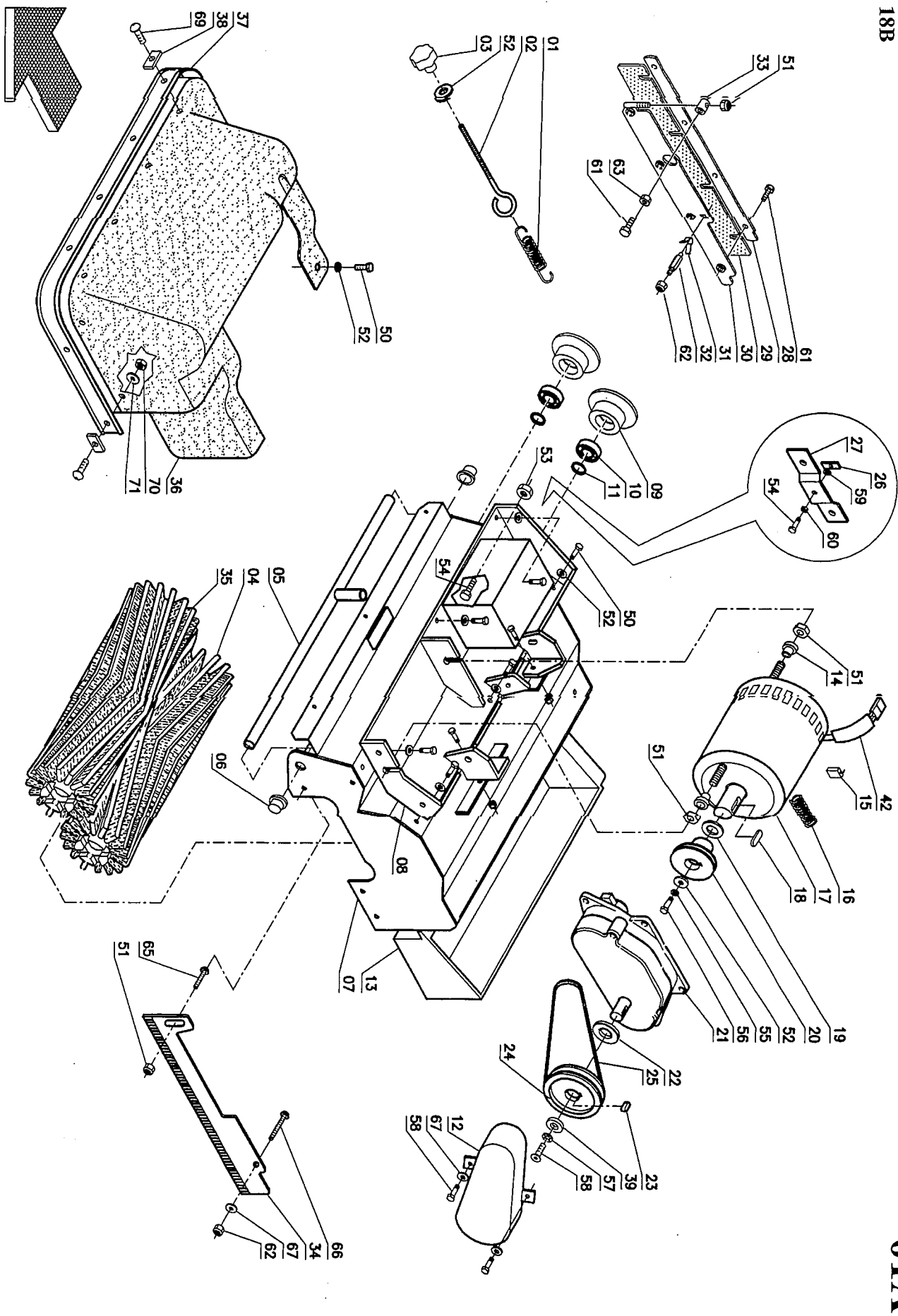

# DRAWING 01A

Item	Part Number	Description	Qty.
1	69220160	Spring	1
2	42307150	Hook	1
3	885046	Handwheel	1
4	66823060	Rear Brush	1
5	42307070	Pipe	1
6	42307080	Cover	2
7	42307130	Tunnel	1
8	42307140	Motor Support	1
9	888530	Right Support	2
10	902028	Bearing	2
11	70720281	Oil Seal	2
12	42207060	Cover	1
13	42307110	Hopper	1
14	42207080	Bushing	2
15	71706092	Carbon Brush Motor	4
16	69210490	Spring	1
17	68220380	Motor	1
18	885030	Key	1
19	69021070	Spacer	1
20	69410180	Motor Pulley	1
21	883530	Reduction Gear Assembly	1
22	888230	Spacer	1
23	885031	Key	1
24	886931	Pulley	1
25	70110014	Belt	1
26	924024	Wing Nut	1
27	885132	Bar	1
28	887231	Blade	1
29	887530	Side Rubber Right	1
30	881332	Side Bar Right	1
31	884530	Coupler	1

Item	Part Number	Description	Qty.
32	884531	Hook Head	1
33	882432	Coupling	1
34	881334	Side Bar Left	1
35	66823050	Front Brush	1
36	42346060	Base Cover	1
37	42346070	Bumper	1
38	882131	Clip Guard	6
39	980038	Washer	1
42	<i>67404160</i>	Sheath	1
50	964107	Screw	
51	924026	Lock Nut	
52	980042	Washer	
53	924035	Nut	
54	964060	Screw	
55	71106009	Lock Washer	
56	964116	Screw	
57	71010506	Lock Washer	
58	964082	Screw	
59	980069	Lock Washer	
60	924025	Nut	
61	964075	Screw	
62	924032	Lock Nut	
63	924034	Nut	
65	964061	Screw	
66	964077	Screw	
67	71105003	Washer	
69	964099	Screw	
70	924029	Lock Nut	
71	980057	Washer	

Note: New Part Numbers in Italics.

BRUSH BASE ASSEMBLY  
20B & 20BT

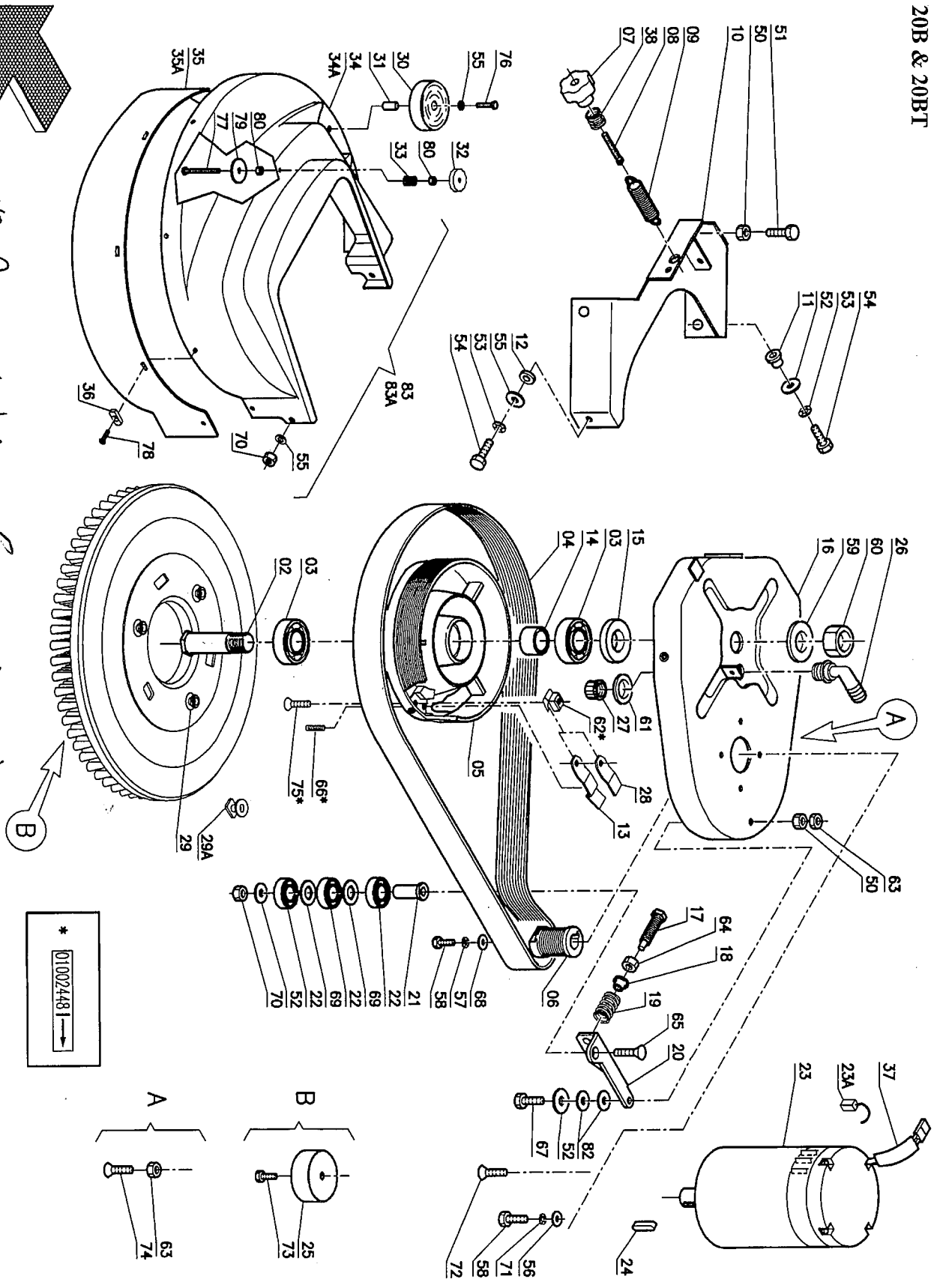

\* PAD Holder (NOT shown) (yellow or blue)  
PART # 504470

\* 010024481

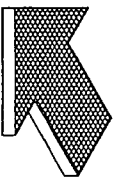



# DRAWING 01

Item	Part Number	Description	Qty.
1	880960	Brush (20B & BT)	
	885960	Pad Driver (20B & BT)	
<del>50470</del>	<del>884541</del>	Pad Holder, Top & Bottom, Yellow	1
2	887740	Shaft	1
3	902031	Bearing	2
4	903016	Belt	1
5	886940	Pulley	1
6	69420260	Motor Pulley	1
7	74006010	Knob	1
8	880540	Adjuster	1
9	888340	Spring	1
10	42301020	Support	1
11	881140	Bushing	2
12	69102050	Bushing	2
13	888341	Spring	2
14	888241	Spacer	1
15	888240	Spacer	1
16	<del>880960</del>	Brush Base <del>(8803010)</del>	1
17	880541	Adjuster	1
18	881141	Bushing	1
19	888342	Spring	1
20	42301010	Support	1
21	881142	Bushing	1
22	902032	Bearing	3
23	68220370	Motor	1
23A	880952	Carbon Brush Motor	4
24	70405041	Key	1
25	980620	Special Washer	1
26	74520028	Connector	1
27	74520029	Ring Nut	1
28	69230470	Spring	3
29	885146	Lugs, rectangular	-
	42001170	Lugs, round head with rectangular base to convert old pad driver to round lugs	
	022.111	Lugs, round	3
	70970603	Screws for Lugs	3
*30	67020030	Bumper Wheel	1
*31	69102110	Bushing	1
*32	42346050	Handwheel	1

Note: New Part Numbers in Italics.

Item	Part Number	Description	Qty.
*33	69210400	Spring	1
*34	42346120	Base Cover	1
*35	67623020	Splash Guard	1
*36	882131	Clip Guard	8
37	67404160	Sheath	1
38	69210640	Spring	1
50	924035	Nut	3
51	964085	Screw	1
52	980044	Washer	2
53	980069	Lock Washer	1
54	964086	Screw	2
*55	980039	Washer	2
56	980042	Washer	3
57	980045	Lock Washer	1
58	964116	Screw	4
59	980050	Washer	1
60	924040	Nut	1
61	71316002	Lock Washer	1
62	71050602	Nut	1
63	71010809	Nut	1
64	924039	Nut	1
65	70980815	Screw	1
66	70960601	Dowel	1
67	964091	Screw	1
68	71106006	Washer	1
69	980052	Washer Brass	2
*70	924033	Lock Nut	1
71	71106009	Lock Washer	4
72	70980602	Screw	1
73	70980614	Screw	1
74	964093	Screw	1
75	70980603	Screw	1
76	70910816	Screw	1
*77	70910631	Screw	1
*78	70944204	Screw	8
*79	71106017	Lock Nut	1
*80	71010603	Nut	2
82	980051	Cupped Washer	2
*83	44623005	Base Cover Assembly	

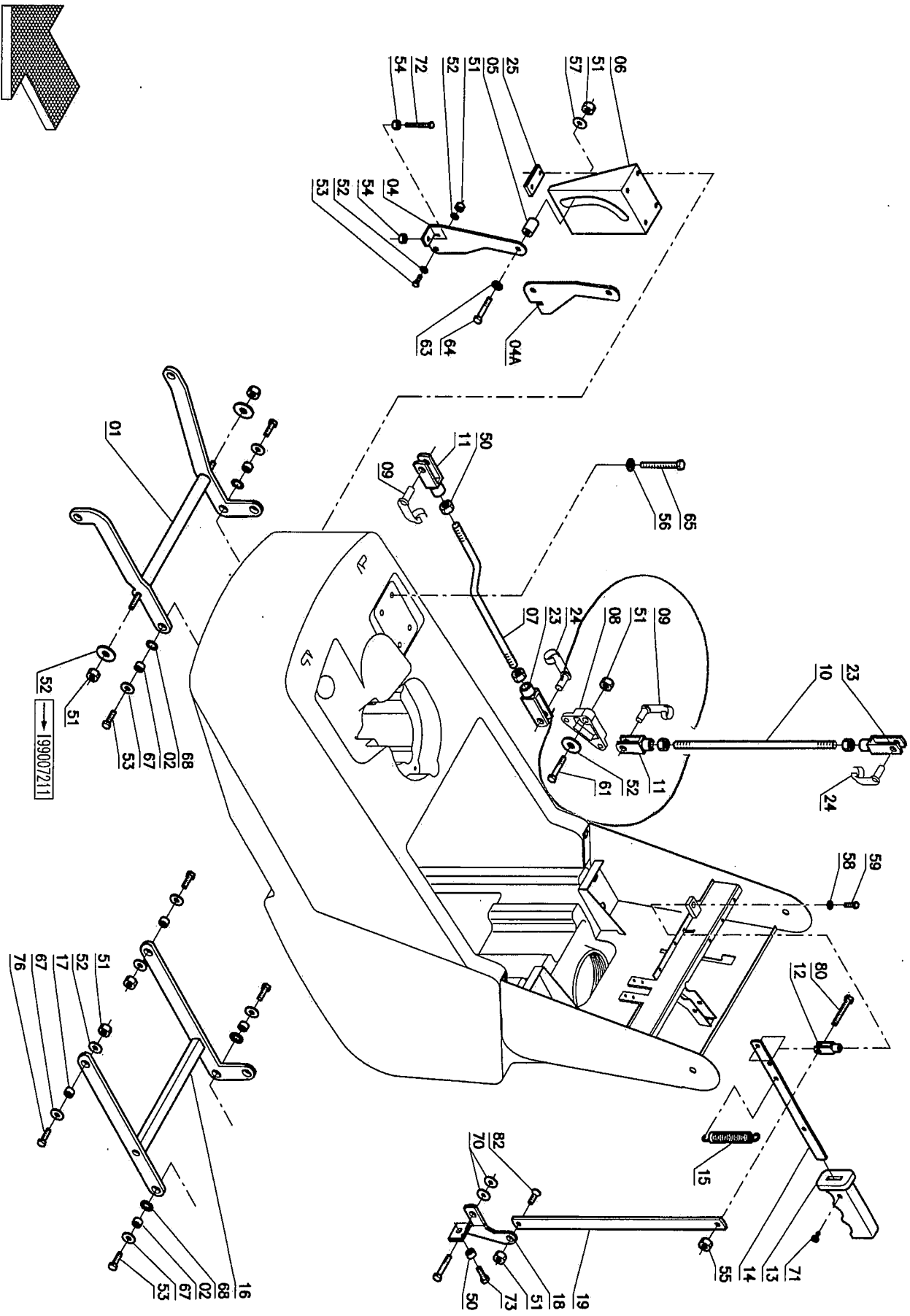

# DRAWING 02

Item	Part Number	Description	Qty.
1	42303120	Arm	1
2	69122030	Bushing	2
4	42303070	Support - 20B	1
4A	42303070	Support - 18B	1
5	42303080	Roller	1
6	42303030	Support	1
7	42303140	Tie Rod	1
8	40228020	Rocker Arm	1
9	74620001	Pin	3
10	42303130	Tie Rod	1
11	74610001	Fork	3
12	74610004	Fork	1
13	74100007	Knob	1
14	42303150	Lever	1
15	888336	Spring	1
16	42307120	Lever	1
17	69102050	Bushing	2
18	42303160	Coupling	1
19	42303170	Prop	1
23	74610005	Fork	1
24	74620006	Pin	1
25	42303180	Plate	2
50	71010809	Nut	5

Item	Part Number	Description	Qty.
51	924033	Lock Nut	5
52	980039	Washer	4
53	964090	Screw	1
54	71010601	Nut	2
55	924026	Lock Nut	1
56	980042	Washer	1
57	980070	Washer	1
58	980040	Washer	1
59	964116	Screw	1
61	70911024	Screw	1
63	980069	Lock Washer	1
64	964106	Screw	1
65	70910620	Screw	1
67	980044	Washer	4
68	980053	Lock Washer	2
70	71110005	Washer	2
71	70944801	Screw	1
72	70910626	Screw	1
73	964103	Screw	1
76	964085	Screw	2
80	70910618	Screw	1
82	70980809	Screw	1

Note: New Part Numbers in Italics.



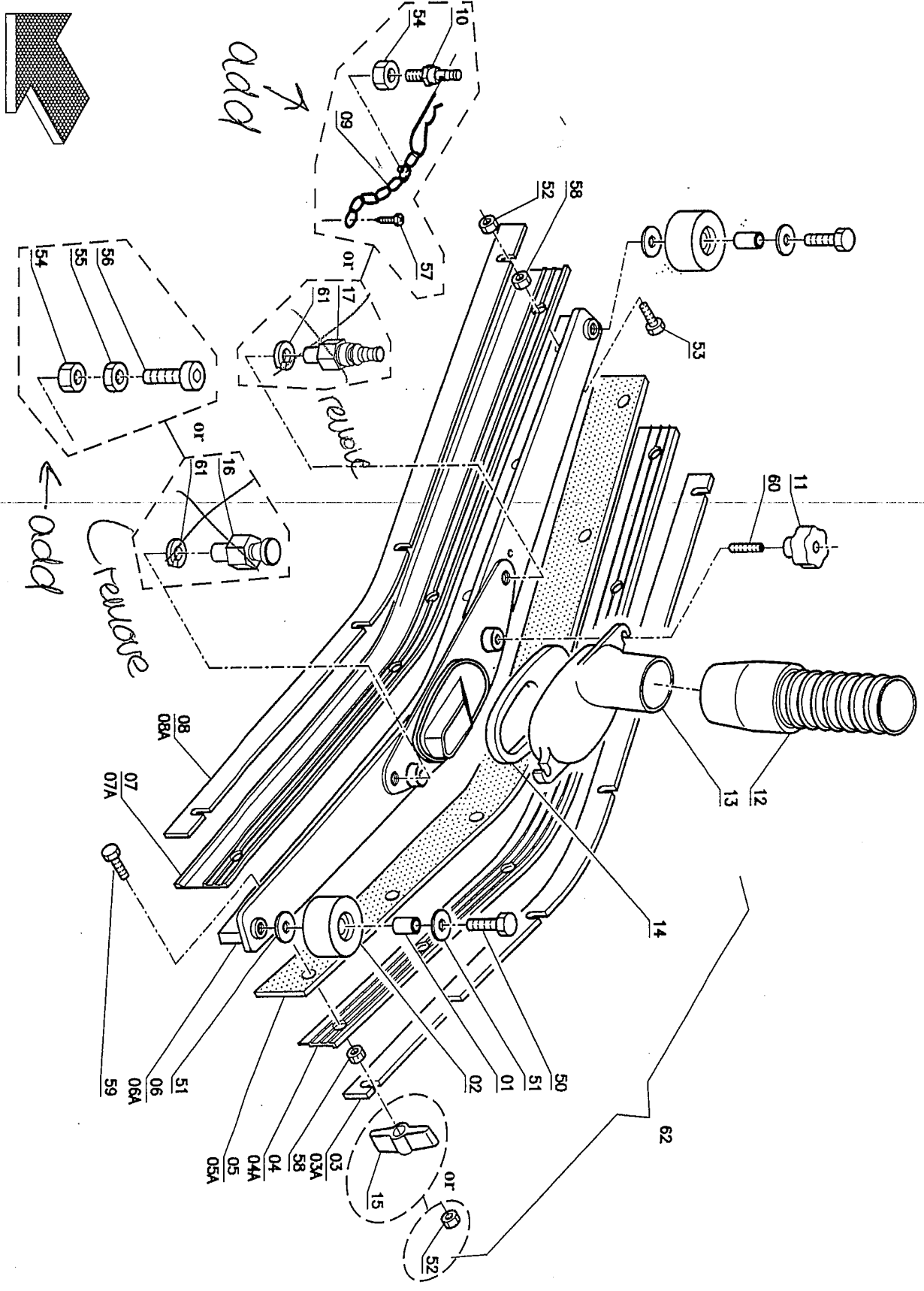

# DRAWING 03

Item	Part Number	Description	Qty.
1	881145	Bushing	2
2	889742	Bum per	2
3	68813020	Blade	1
4	880750	Rear Rubber	1
5A	880751	Central Rubber, 33 Shore, Sm tooth Floor, Red, 31"	1
5B	880752	Central Rubber, 40 Shore, Concrete Floor, Beige, 31"	1
5C	67713060	Central Rubber, Oil Resistant <i>Whit</i>	
6	69623010	Squeegee Body	1
7	880753	Front Rubber, Clear	1
8	68813010	Blade	1
9	882444	Chain with Clip	
10	42311010	Stud Bolt	2
11	74006010	Knob	
12	67512690	Vacuum Hose	1
13	880240	Opening	1
14	67406200	Gasket	1
15	74006011	Wing Nut	8
16	42311030	Stud Bolt	1
17	42311020	Stud Bolt	1
50	964085	Screw	2
51	980039	Washer	2
52	924050	Lock Nut	
53	964109	Screw	4
54	924061	Nut	
55	924053	Nut	
56	70931005	Screw <i>70911006</i>	
57	964126	Screw	
58	924054	Nut	12
59	964110	Screw	8
60	925606	Dowel	2
61	71110007	Lock Washer	2
62	A 9623001	Squeegee Assembly, includes all items above, except item 12, the vacuum hose.	
62	A 9623004	Squeegee Assembly, includes all items above, except item 12, the vacuum hose.	

Note: New Part Numbers in Italics.

Does Squeegee  
 Assembly connect to  
 machine with:  
 cater pins?  
 quick connects?

SQUEEGEE CONTROL ASSEMBLY

04

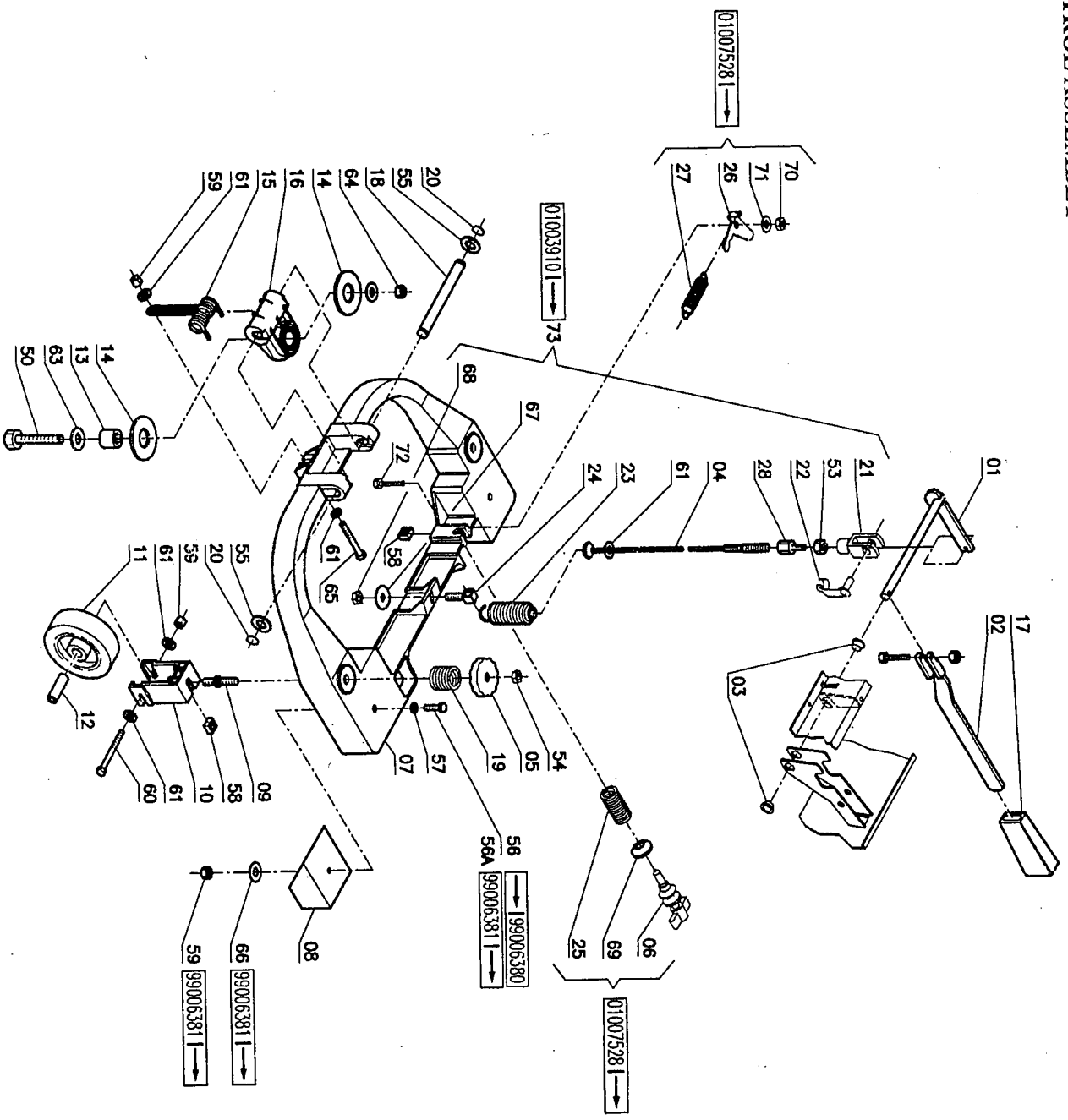

# DRAWING 04

Item	Part Number	Description	Qty.
1	42312050	Lever	1
2	42312070	Lever	1
3	69122010	Bushing	2
4	74803062	Cable	1
5	924049	Handwheel	3
6	42312120	Adjuster	2
7	42312040	Arm	1
8	42312080	Ballast	2
9	42312060	Pin	2
10	42312030	Support	2
11	67010050	Wheel	1
12	69122020	Bushing	2
13	69122040	Bushing	1
14	41312080	Special Washer	2
15	69230020	Spring	1
16	42312010	Coupling	1
17	74100005	Knob	1
18	42312020	Pin	1
19	69210330	Spring	2
20	70230006	Seeger Ring	2
21	74610007	Fork	1
22	74620008	Clip	1
23	69220190	Spring	1
24	42312100	Coupling	1
25	69210660	Spring	1

Item	Part Number	Description	Qty.
26	42312140	Coupler	1
27	69220560	Spring	1
28	42312130	Extension Tube	1
50	70911009	Screw	1
53	924060	Nut	1
54	71010809	Nut	2
55	980046	Washer	2
56	70910621	Screw	2
57	71106009	Lock Washer	2
58	71010810	Special Nut	3
59	924026	Lock Nut	5
60	70910627	Screw	2
61	980042	Washer	6
63	71110011	Lock Washer	1
64	924055	Screw	1
65	70910621	Screw	1
66	980065	Washer	2
67	71106005	Washer	1
68	924050	Lock Nut	1
69	71312002	Washer	1
70	71020801	Lock Nut	1
71	71108005	Washer	1
72	70910804	Screw	1
73	A2312001	Kit - Squeegee Cable Lift	

Note: New Part Numbers in Italics.



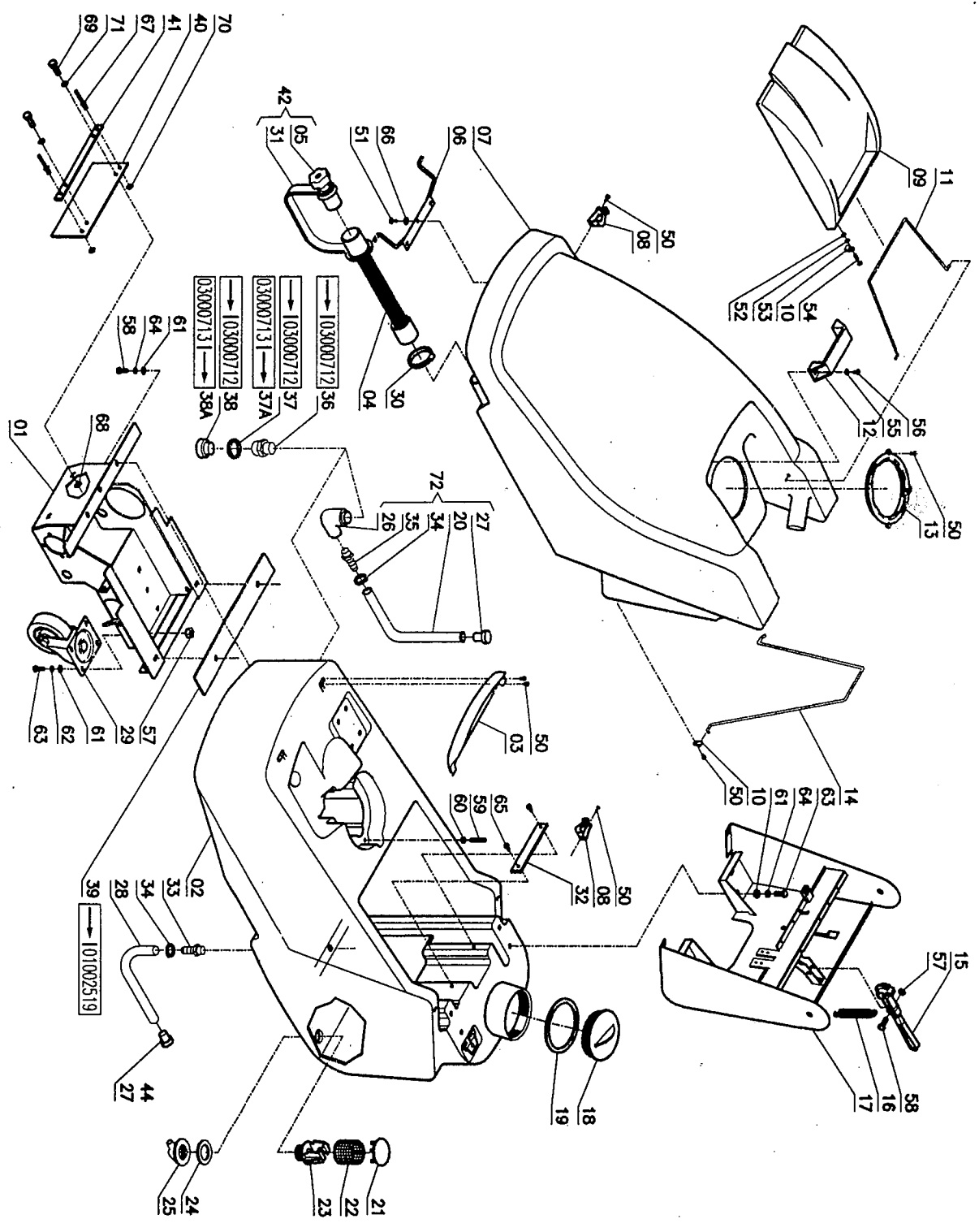

# DRAWING 05

Item	Part Number	Description	Qty.
1	69923100	Frame	1
2	69723040	Solution Tank	1
3	42346080	Cover	1
4	67512680	Drain Hose	1
5	886842	Plug, Drain Hose	1
6	42336080	Hinge	1
7	69723050	Recovery Tank	1
8	882440	Hook	1
9	42346020	Cover	1
10	72902008	Cable Fastener	4
11	42346010	Hinge	1
12	883930	Handle	1
13	42036030	Filter Holder	1
14	42336030	Prop	1
15	885143	Lever	1
16	888344	Spring	1
17	69923300	Frame	1
18	886844	Cover	1
19	67401080	Gasket	1
20	67523260	Pipe	1
21	882331	Cover	1
22	883331	Filter	1
23	883332	Base	1
24	70800003	Gasket	1
25	74520025	Ring Nut	1
26	74520001	Elbow	1
27	886852	Cap	2
28	67521670	Pipe	1
29	67050120	Castor Wheel	1
30	882041	Clamp	1
31	42341010	Clamp	1
32	42336090	Guide	1
33	74540002	Connector	1
34	74220061	Clamp	1

Item	Part Number	Description	Qty.
35	74540023	Connector	1
36	74560009	Fitting, 1/2" Pipe Thread	1
37	67400640	Gasket	1
37A	67406220	Gasket	1
38	74550009	Cap	1
38A	74550012	Plug Exhaust Pipe	1
39	42316010	Support Bracket	1
40	42346090	Splash Guard	1
41	42346100	Blade	1
42	42436030	Plug & Clamp, Drain Hose	12
50	70973902	Screw	3
51	70945501	Screw	2
52	924029	Lock Nut	2
53	71104002	Washer	2
54	70950401	Screw	2
55	980066	Washer	2
56	70944807	Screw	2
57	924033	Lock Nut	5
58	964103	Screw	1
59	925606	Dowel	1
60	924048	Nut	2
61	980039	Washer	10
62	980053	Lock Washer	4
63	70930808	Screw	8
64	980069	Lock Washer	6
65	70944203	Screw	2
66	71105003	Washer	3
67	71400004	Rivet	2
68	71050503	Nut	2
69	70910504	Screw	2
70	71103004	Washer	2
71	71105001	Washer	2
72	A3623001	Drain Hose Kit (Optional)	

Note: New Part Numbers in Italics.

BRAKE & TRACTION ASSEMBLY

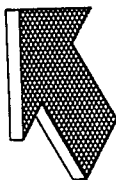
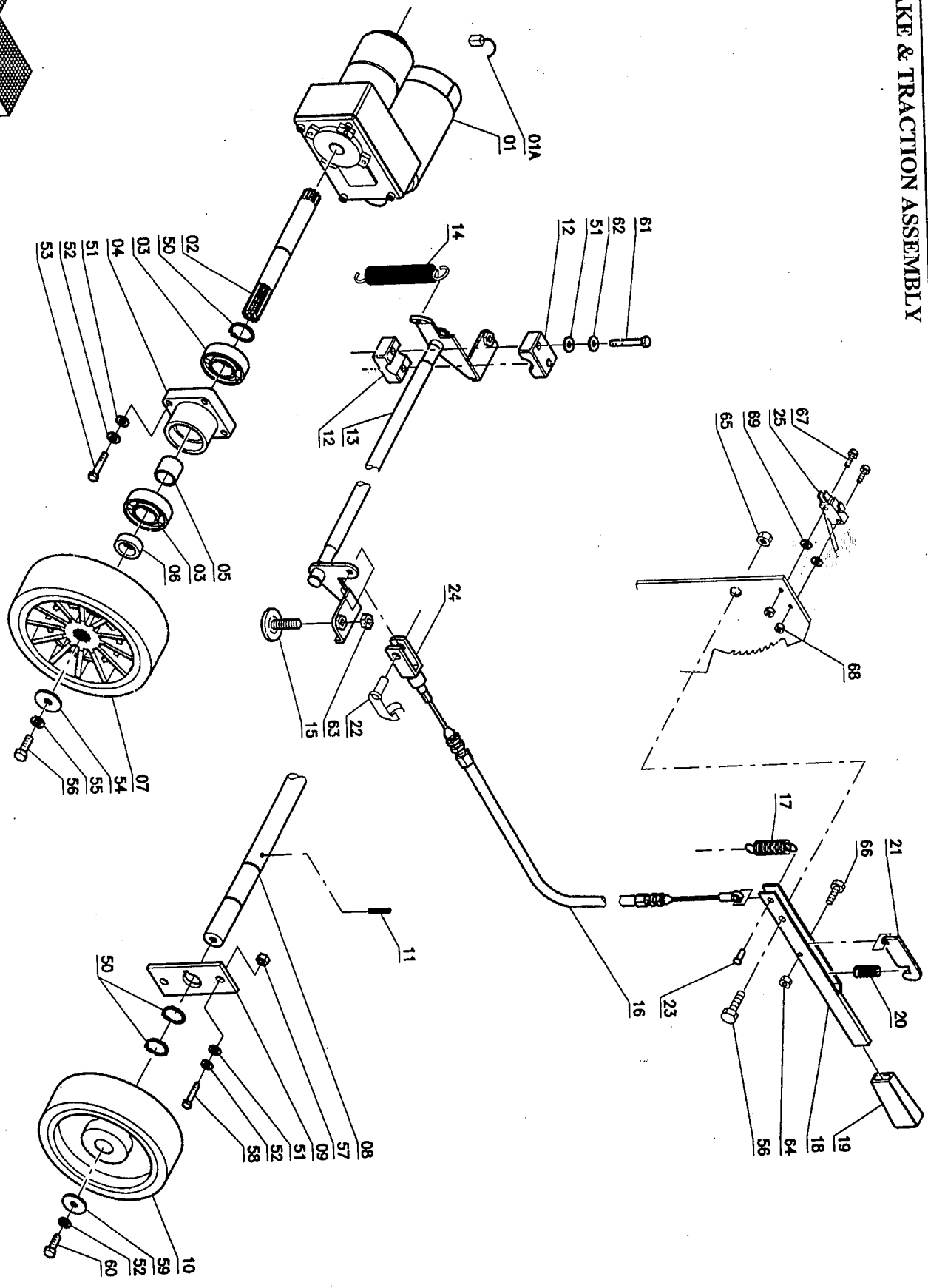

# DRAWING 06

Item	Part Number	Description	Qty.
1	68200290	Motor	1
1A	71707142	Carbon Brushes	2
2	68923010	Axle Shaft	2
3	70512002	Bearing	4
4	42317010	Support	2
5	69022010	Spacer	2
6	69022020	Spacer	2
7	67030570	Wheel, Traction	2
8	42317020	Shaft	1
9	42317030	Support	2
10	67010300	Wheel	2
11	71404001	Spring Pin	1
12	40502010	Holdfast	4
13	42318030	Shaft	1
14	69220160	Spring	1
15	41318090	Pad	2
16	74803051	Brake Cable	1
17	69220440	Spring	1
18	40318100	Lever	1
19	74100005	Knob	1
20	69210540	Spring	1
21	40318110	Lever	1
22	74620005	Pin	1

Item	Part Number	Description	Qty.
23	74620007	Pin	1
24	74610004	Fork	1
25	72105009	Microswitch	1
50	70220016	Seeger Ring	4
51	980042	Washer	8
52	980045	Lock Washer	8
53	70910624	Screw	8
54	71108008	Washer	2
55	71308001	Lock Washer	2
56	70910804	Screw	3
57	924026	Lock Nut	4
58	964116	Screw	4
59	980065	Washer	2
60	964107	Screw	2
61	70910625	Screw	4
62	71106009	Lock Washer	4
63	71010809	Nut	2
64	71020401	Lock Nut	1
65	71020801	Lock Nut	1
66	70910407	Screw	1
67	70940304	Screw	2
68	71020301	Lock Nut	2
69	71103002	Washer	2

Note: New Part Numbers in Italics.

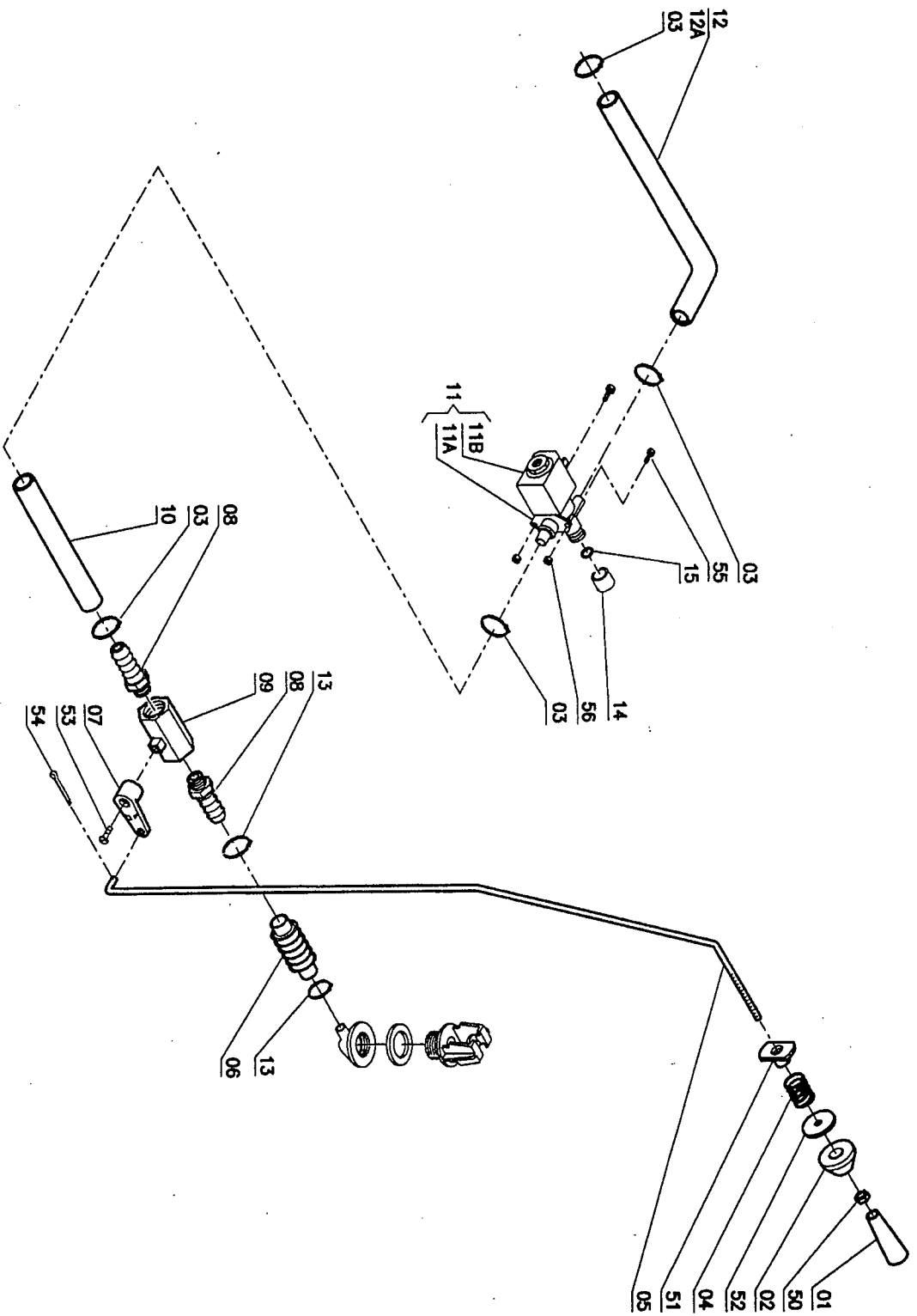

# DRAWING 07

Item	Part Number	Description	Qty.
1	885044	Knob	1
2	980621	Special Washer	1
3	7421002	Clamp	4
4	888345	Spring	1
5	4237010	Rod	1
6	40237100	Bellows	1
7	4237020	Lever	1
8	883347	Connector	2
9	889440	Cock	1
10	67522250	Pipe	1
11	68532050	Solenoid Valve Complete	1
11A	68510090	Body, Solenoid Valve	
11B	68522070	Coil	
12	67523050	Pipe - 20B	1
12A	67523330	Pipe - 18B	1
13	74210001	Clamp	4
14	74550011	Cap	1
15	70800020	O-Ring	1
50	924046	Nut	
51	924047	Nut	
52	980061	Washer	
53	70950401	Screw	
54	925609	Split Pin	
55	70910401	Screw	
56	924029	Lock Nut	

Note: New Part Numbers in Italics.

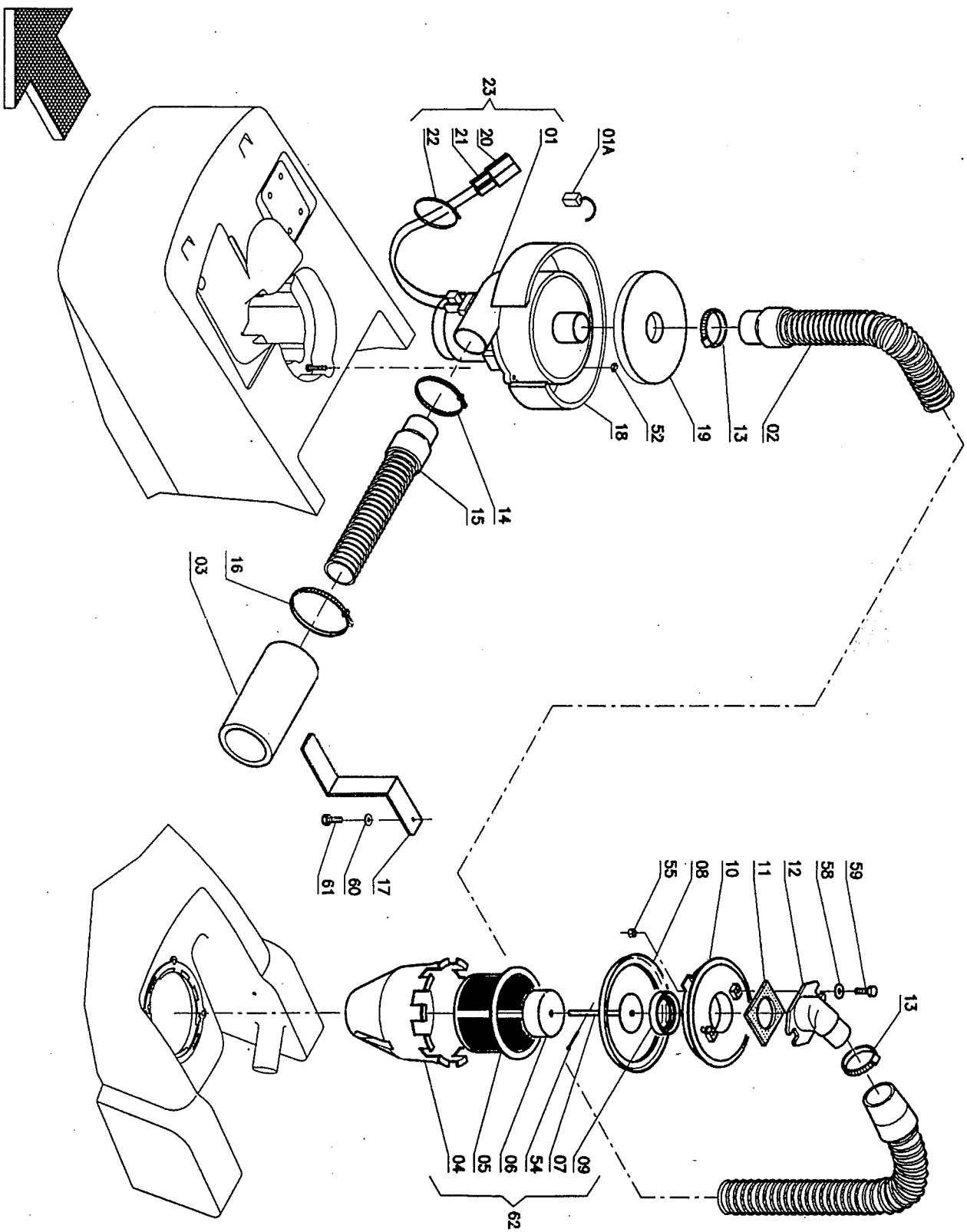

# DRAWING 08

Item	Part Number	Description	Qty.
1	68120450	Vacuum Motor	1
1A	880951	Carbon Brush Motor	2
2	67512630	Vacuum Hose	1
3	67101390	Sound Deadening Hose	1
4	888551	Protection	1
5	883343	Filter	1
6	883344	Float	1
7	887440	Rod	1
8	883441	Gasket	1
9	883442	Gasket	1
10	886841	Cover	1
11	883446	Gasket	1
12	882442	Opening	1
13	882041	Clamp	1
14	74220059	Clamp	1
15	67512050	Pipe	1
16	882030	Clamp	1
17	42341020	Support	1
18	67101090	Deading Hose	1
19	67101080	Deading Hose	1
20	72700003	Connector	2
21	72700004	Contact	2
22	74210001	Clamp	2
23	68120460	Vacuum Motor Assembly	1
52	924050	Lock Nut	1
54	925603	Split Pin	2
55	71020502	Lock Nut	2
58	40247030	Washer	2
59	70950502	Screw	2
60	980039	Washer	1
61	70910803	Screw	1
62	A6520001	Filter/Float Assembly	1

Note: New Part Numbers in Italics.



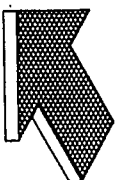
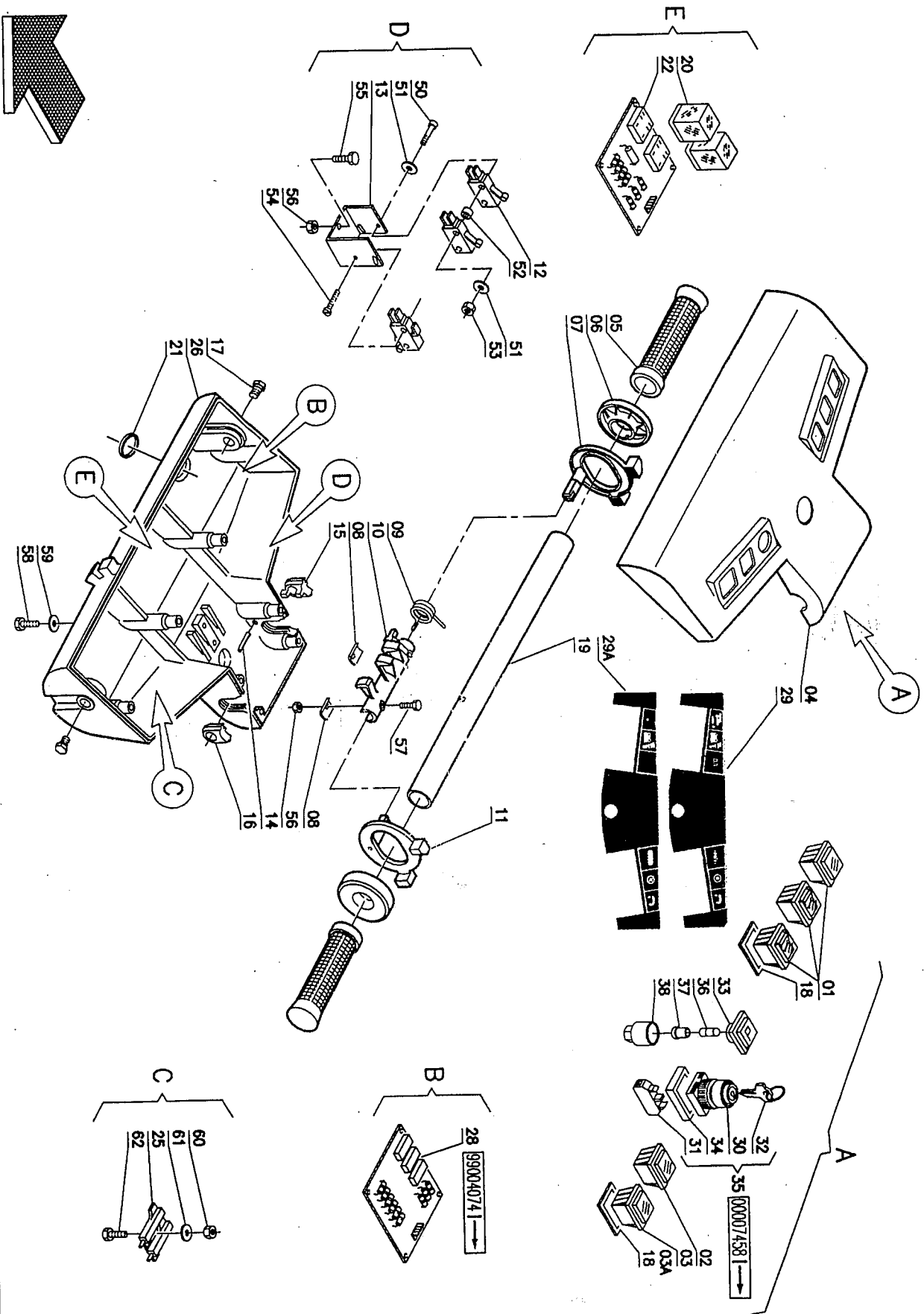

# DRAWING 09 - TRACTION MODELS

Item	Part Number	Description	Qty.
1	72102009	Switch	3
2	72300117	Battery Warning Light	1
3	72102010	Switch	1
3A	72300216	Switch - 18B	1
4	882342	Handle Bar Cover	1
5	885042	Knob	2
6	980623	Special Washer	2
7	885141	Lever	1
8	882140	Clip Retaining	2
9	888343	Spring	1
10	41328010	Shaft	1
11	885142	Lever	1
12	911170	Microswitch	1
13	41328040	Support	1
14	71404005	Spring Pin	1
15	887240	Retainer RH	1
16	887241	Retainer LH	1
17	42326010	Special Screw	2
18	883440	Gasket	5
19	886040	Pipe	1
20	68420510	Relay	2
21	883841	Fairlead	1
22	67900028	Chopper Card	1
25	72600006	Braking Resistance	1
26	881341	Handle Bar Body	1
28	67903001	Check Card Batteries	1
29	66401306	Decal	1
29A	66401320	Decal-18BT	1

Item	Part Number	Description	Qty.
	72199012	KEYS PRIOR TO 8/2000	
	72107004	"Sw Body W/Ring,Support&2 Keys" NO CVR	
	72908010	Contact Only	
		Keys, Set of Two, NO COVER	
		KEYS BEGINNING 8/2000	
30	72199015	Sw Body W/Ring&2 Keys- GREY CVR	1
31	72107005	Contact Only	1
32	72908017	Keys, Set of 2, GREY COVER	1
33	72300205	Red Light	1
34	72199018	Flange/Support for Key with Switch Body	1
	72199016	Switch Kit, Older Style-No cover	
35	72199017	Switch Kit, Newer Style-Gray cover	1
36	72300006	Bulb	1
37	72300207	Holder, Bulb	1
38	72300201	Body	1
50	70940305	Screw	3
51	71104001	Washer	3
52	71104004	Washer	2
53	924043	Lock Nut	2
54	70940302	Screw	1
55	70910407	Screw	4
56	924031	Nut	2
57	964101	Screw	2
58	964123	Screw	6
59	980041	Lock Washer	6
60	71060501	Nut	1
61	71106007	Washer	1
62	70950504	Screw	1

Note: New Part Numbers in Italics.

HANDLE ASSEMBLY  
MODELS WITHOUT TRACTION

09A

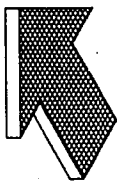
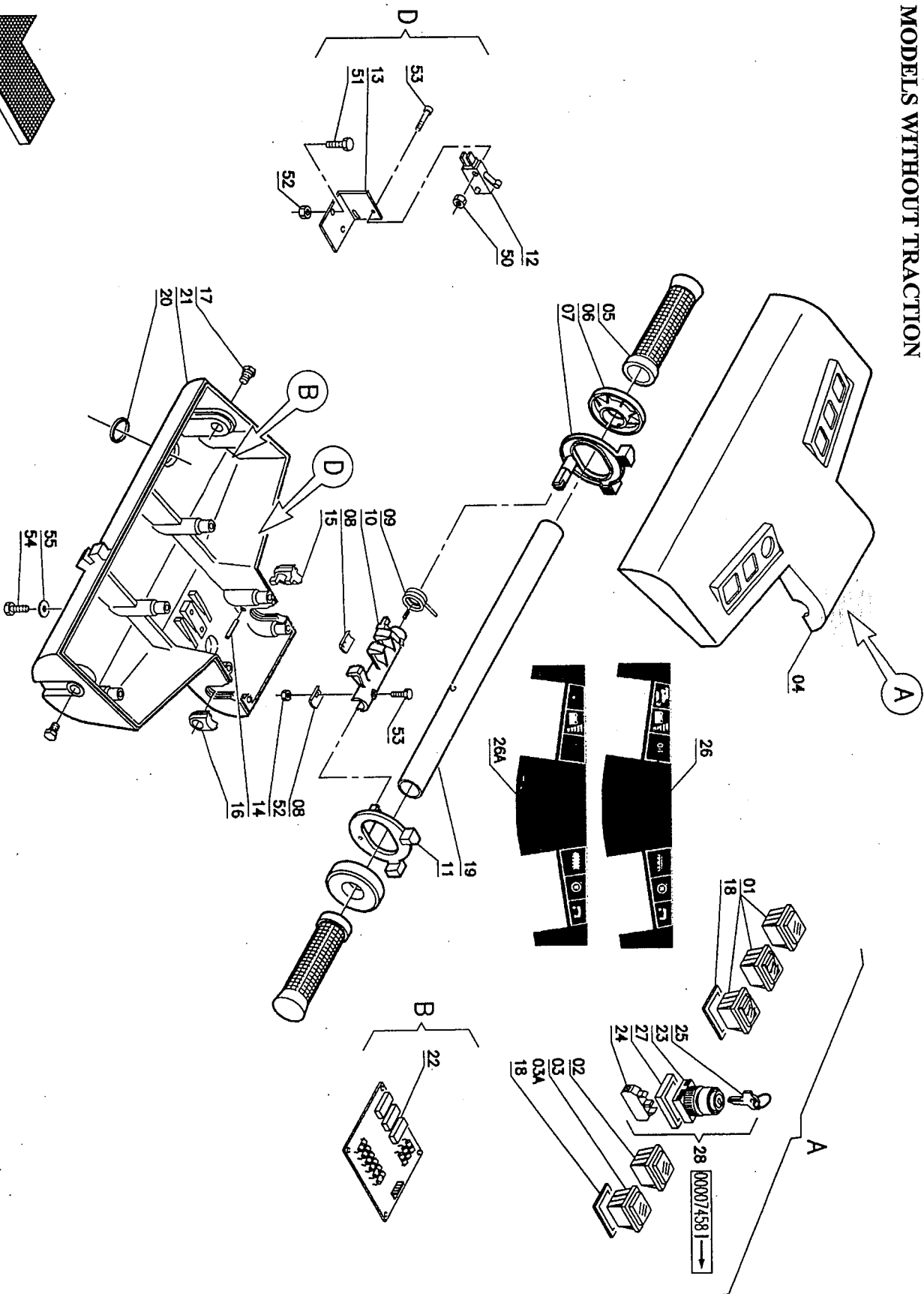

# DRAWING 09A

Item	Part Number	Description	Qty.
1	72102009	Switch	3
2	911167	Signal Lamp Green	1
3	<i>72102010</i>	Switch, Brush Release, 20B	1
3A	882343	Switch, Brush Release, 18B	1
4	882342	Handle Bar Cover	1
5	885042	Knob	2
6	980623	Special Washer	2
7	885141	Lever	1
8	882140	Clip Retaining	2
9	888343	Spring	1
10	41328010	Shaft	1
11	885142	Lever	1
12	911170	Microswitch	1
13	888548	Support	1
14	71404005	Spring Pin	1
15	887240	Retainer RH	1
16	887241	Retainer LH	1
17	42326010	Special Screw	2
18	883440	Gasket	5
19	886040	Pipe	1
20	883841	Fairlead	1
21	881341	Handle Bar Body	1
22	881358	Check Card Batteries	1
		<b>KEYS PRIMARILY USED PRIOR TO 8/2000</b>	
	72199012	"Sw Body W/Ring, Support & Two Keys" NO COVER	1
	72107004	Contact Only	1
	72908010	Keys, Set of Two, NO COVER	1
		<b>KEYS PRIMARILY USED BEGINNING 8/2000</b>	
23	72199015	"Sw Body W/Ring & Two Keys" GREY RUBBER COVER	1
24	72107005	Contact Only	1
25	72908017	Keys, Set of Two, GREY RUBBER COVER	1
26	66401341	Decal, 20B	1
26A	66401342	Decal, 18B	1
27	72199018	Flange/Support for Key with Switch Body	1
	72199016	Switch Kit, Older Style-No cover	
28A	72199017	Switch Kit, Newer Style-Gray cover	1
50	924043	Lock Nut	5
51	70910407	Screw	4
52	924031	Nut	2
53	964101	Screw	4
54	964123	Screw	8
55	980041	Lock Washer	2

Note: New Part Numbers in Italics.

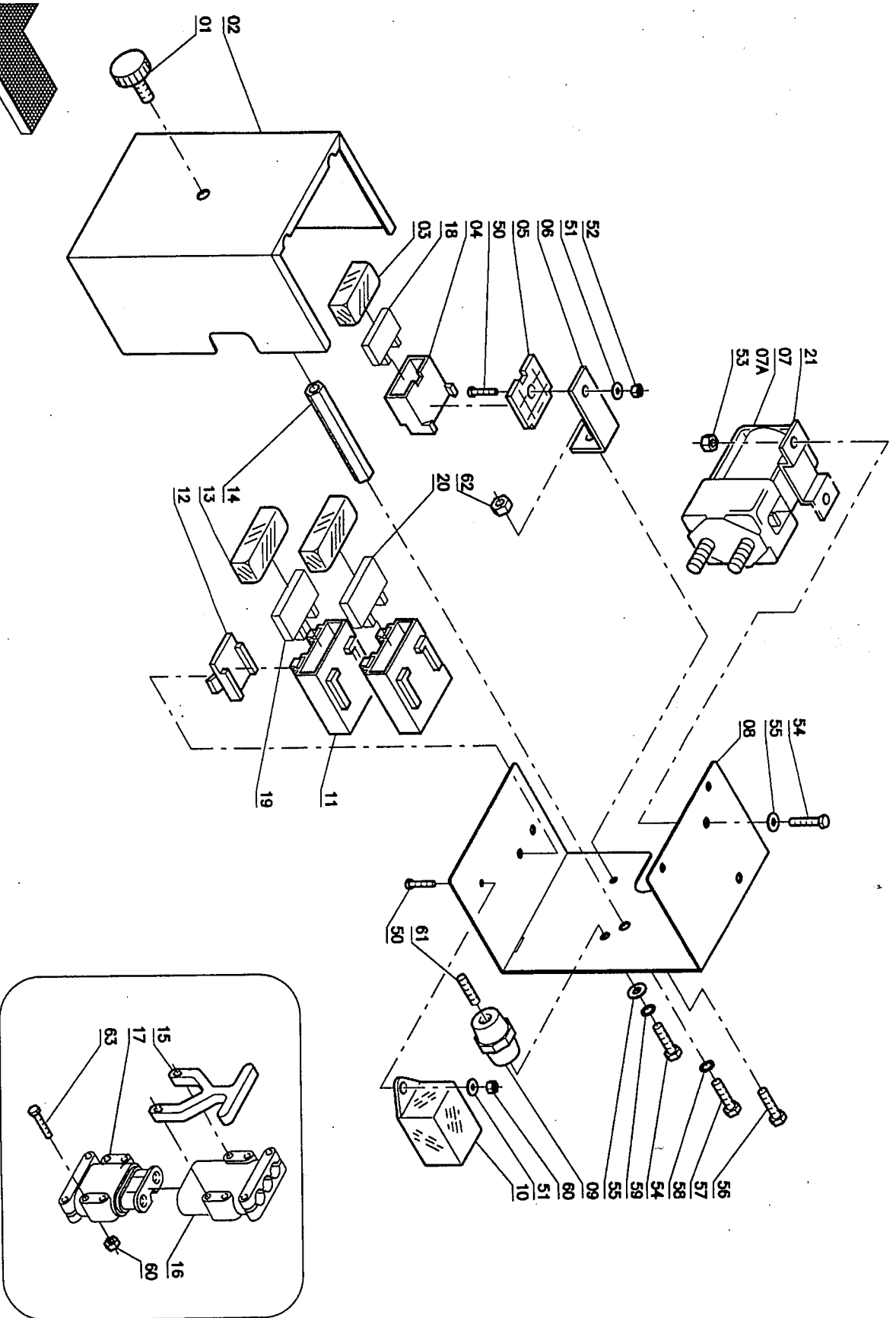

# DRAWING 10

Item	Part Number	Description	Qty.
1	74006003	Knob	1
2	42351020	Cover	1
3	72916002	Cover	1
4	72400011	Fuseholder	1
5	72916001	Plaque	1
6	41251100	Support	1
7	68420220	Double Remote Control Switch, 20B	1
7A	68420110	Remote Control Switch, 18B	1
8	72351010	Cover	1
9	884750	Insulator	1
10	887550	Relay	1
11	72400012	Fuseholder	2
12	72916004	Plaque	1
13	72916003	Cover	2
14	42351030	Stud Bolt	1
15	72700015	Lever for Connector	1
16	72700014	Connector Male	1
17	72700013	Connector Female	1
18	72400301	Fuse	1
19	72403003	Fuse	1
20	72405002	Maxifuse	1
21	72906002	Support	1
50	70940301	Screw	2
51	980054	Washer	2
52	71010301	Nut	1
53	924032	Lock Nut	3
54	964082	Screw	3
55	980066	Washer	3
56	964098	Screw	1
57	964088	Screw	1
58	980045	Lock Washer	1
59	980041	Lock Washer	3
60	924043	Lock Nut	3
61	70960502	Dowel	1
62	924029	Lock Nut	1
63	70940305	Screw	2

Note: New Part Numbers in Italics.

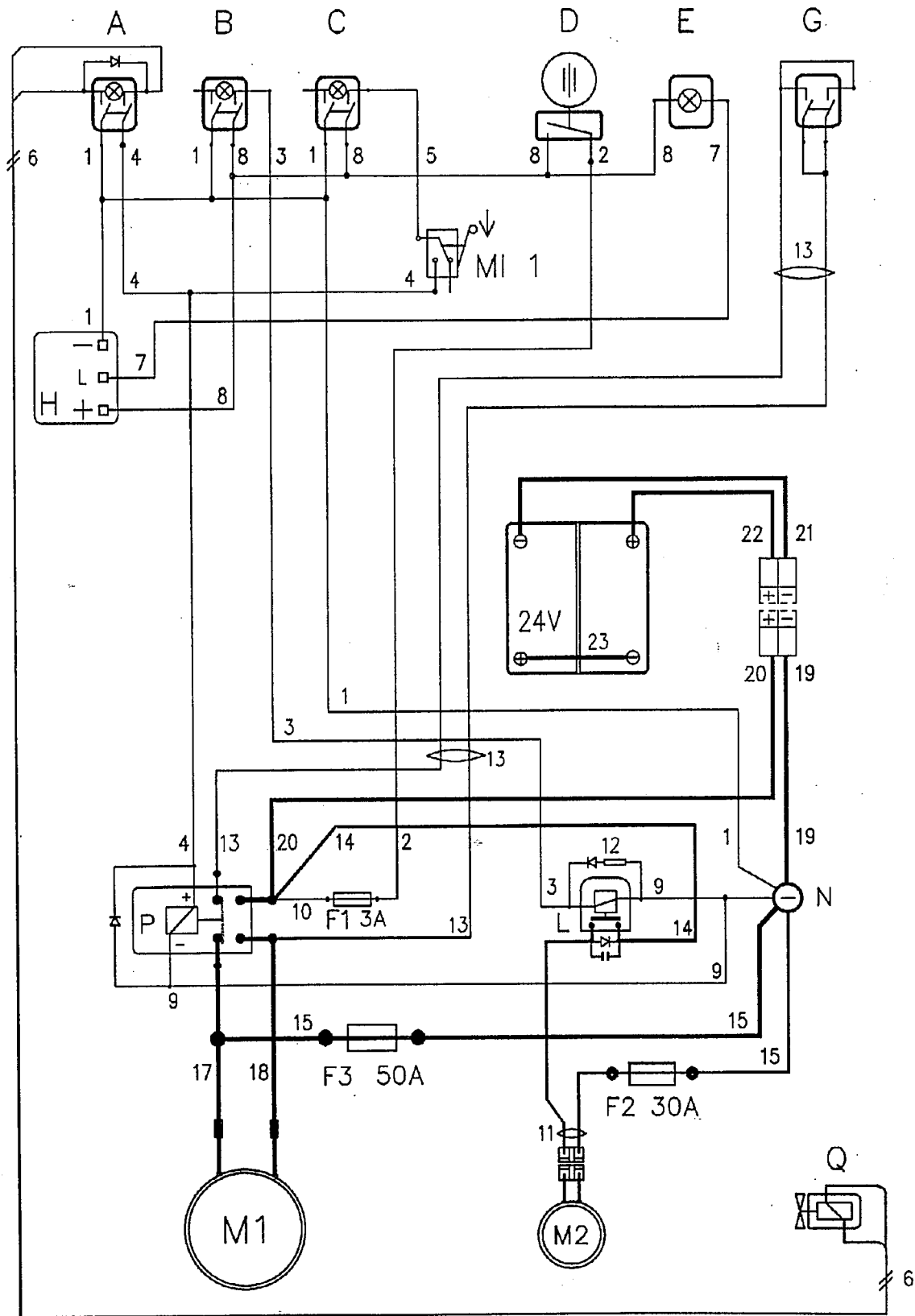

Item	Part Number	Component Descriptions
A	72102009	Bipolar Switch Green (Solenoid Valve Solution)
B	72102009	Bipolar Switch Green (Vacuum Motor)
C	72102009	Bipolar Switch Green (Motor Brushes)
D	72107004	Contact/Switch (On/Off General), prior to 8/00
	72107005	Contact/Switch (On/Off General), effective 8/00
E	911167	Green Signal Protected 24V (Control Batteries)
F1	72400301	Fuse 3A (Controls)
F2	72403003	Maxifuse 30A (Vacuum Motor)
F3	72405002	Maxifuse 50A (Brush Motor)
H	67900001	Check Card Control Batteries 24V Lead Batteries
H1	67903002	Check Card Control Batteries 24V Gel Batteries
L	887550	Relay 24V 30A Faston ( Vacuum Motor)
M1	68220370	Brush Motor 24V
M2	68120460	Vacuum Motor 24V with Plug
MI-1	911170	Microswitch 3x22 (Motor Brushes)
N	884750	Insulator M5x25 FF (Negative General)
P	68420230	Remote Control Switch 24V with Diode (Brush Motor)
Q	68522070	Coil Solenoid Valve 24V - 1/2

Item	Part Number	Cable Descriptions
1/6	68023001	Series Cables and connectors for Switches
1	68023033	4 Cables Black No. 1
2	68023034	Cable Brown No. 2
3	68023035	Cable Blue No. 3
4-5	68023036	3 Cables Red No. 4-5
6	68023014	2 Cables Brown-Blue No. 6
7	68023003	Cable Blue No. 7
8	68023004	4 Cables Red No. 8
9	68023005	2 Cables Black No. 9
10	68023006	Cable Red No. 10
11	68023007	Cables Suction Motor No. 11
12	72500011	Diode and Resistance with Terminal No. 12
13	68023002	Series Cables and Connector Brush Release No. 13
14	68023008	Cable Red + Condenser and Diode No. 14
15	68023009	Cable Black No. 15
17/18	68023029	2 Cables Black-Red Motor Brushes No. 17-18
19/20	68023037	2 Cables Black-Red and Connector 80A
21/22	68023038	2 Cables Black-Red and Connector 80A
23	68000154	Cable Bridge with Battery Terminals (+) (-)



Effective March 2001

20B & 18B Functional Schematic

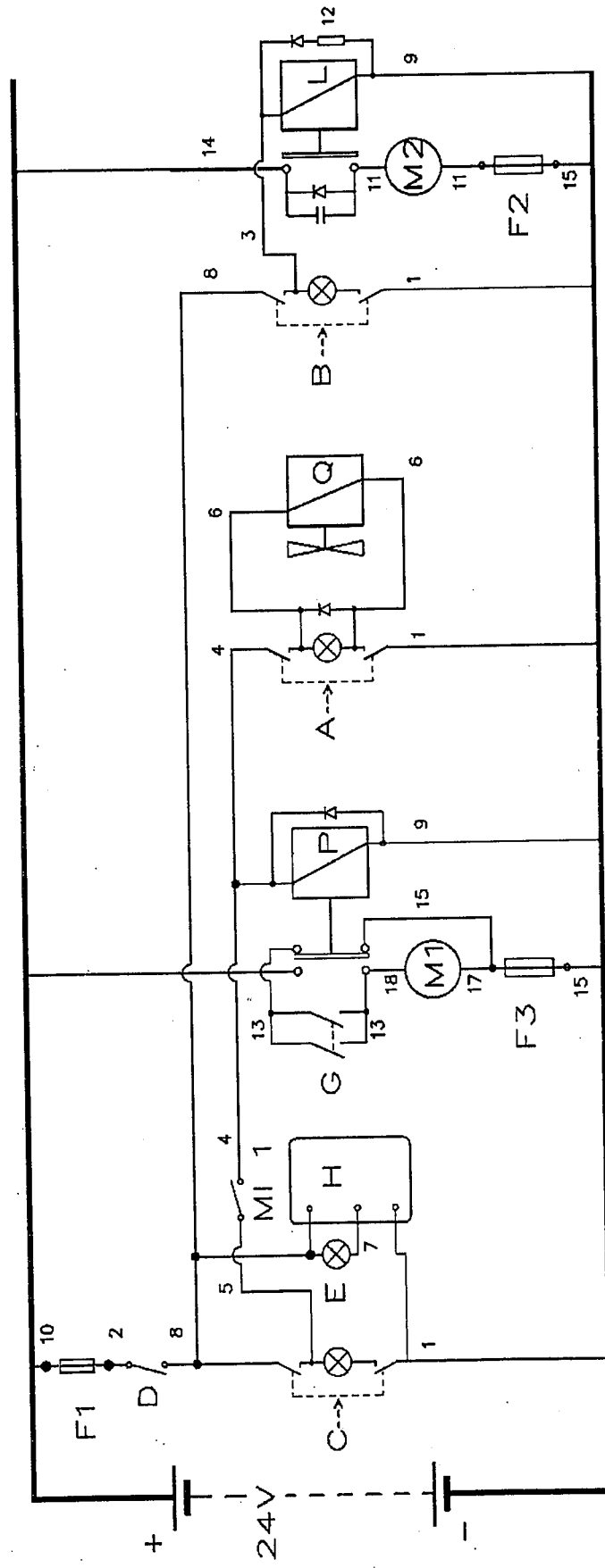

**20B & 18B Electrical Components Parts List**  
**Effective March 2001**

Item	Part Number	Component Descriptions
A	72102009	Bipolar Switch Green (Solenoid Valve Solution)
B	72102009	Bipolar Switch Green (Vacuum Motor)
C	72102009	Bipolar Switch Green (Motor Brushes)
D	72107004	Contact/Switch (On/Off General), prior to 8/00
	72107005	Contact/Switch (On/Off General), effective 8/00
E	911167	Green Signal Protected 24V (Control Batteries)
F1	72400301	Fuse 3A (Controls)
F2	72403003	Maxifuse 30A (Vacuum Motor)
F3	72405002	Maxifuse 50A (Brush Motor)
H	67900001	Check Card Control Batteries 24V Lead Batteries
H1	67903002	Check Card Control Batteries 24V Gel Batteries
L	887550	Relay 24V 30A Faston ( Vacuum Motor)
M1	68220370	Brush Motor 24V
M2	68120460	Vacuum Motor 24V with Plug
MI-1	911170	Microswitch 3x22 (Motor Brushes)
N	884750	Insulator M5x25 FF (Negative General)
P	68420230	Remote Control Switch 24V with Diode (Brush Motor)
Q	68522070	Coil Solenoid Valve 24V - 1/2

Item	Part Number	Cable Descriptions
1/6	68023001	Series Cables and connectors for Switches
1	68023033	4 Cables Black No. 1
2	68023034	Cable Brown No. 2
3	68023035	Cable Blue No. 3
4-5	68023036	3 Cables Red No. 4-5
6	68023014	2 Cables Brown-Blue No. 6
7	68023003	Cable Blue No. 7
8	68023004	4 Cables Red No. 8
9	68023005	2 Cables Black No. 9
10	68023006	Cable Red No. 10
11	68023007	Cables Suction Motor No. 11
12	72500011	Diode and Resistance with Terminal No. 12
13	68023002	Series Cables and Connector Brush Release No. 13
14	68023008	Cable Red + Condenser and Diode No. 14
15	68023009	Cable Black No. 15
17/18	68023029	2 Cables Black-Red Motor Brushes No. 17-18
19/20	68023037	2 Cables Black-Red and Connector 80A
21/22	68023038	2 Cables Black-Red and Connector 80A
23	68000154	Cable Bridge with Battery Terminals (+) (-)

# Electrical Diagram - 20BT & 18BT with Traction

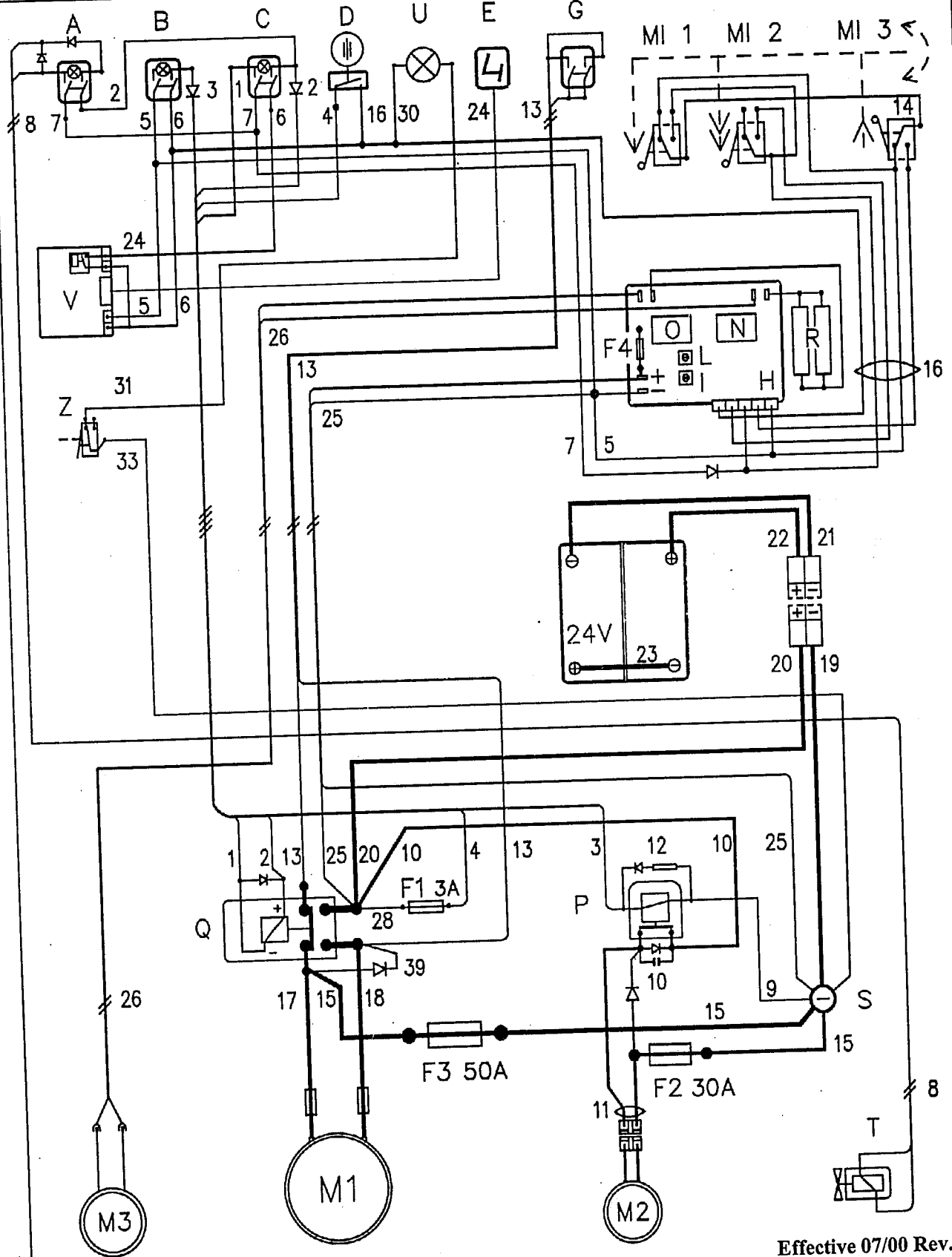

## Electrical Components - 20BT & 18BT with Traction

Item	Part Number	Component Descriptions
A	72102009	Bipolar Switch Green (Solenoid Valve Solution)
B	72102009	Bipolar Switch Green (Vacuum Motor)
C	72102009	Bipolar Switch Green (Brush Motor)
D	72107005	Contact/Switch (On/Off General)
E	72300117	Signal, Battery Indicator
F1	72400301	Fuse 3A
F2	72403003	Maxifuse 30A (Vacuum Motor)
F3	72405002	Maxifuse 50A (Brush Motor)
F4	72403001	Fuse 30A (Chopper Card)
G	72102010	Yellow Switch Brush Release
H	67900028	Chopper Card 24V without Relays
I		Trimmer Adjustment 1st Speed
L		Trimmer Adjustment Acceleration
M1	68220370	Brush Motor 24V
M2	68120460	Vacuum Motor 24V with Plug
M3	68200290	Geared Motor 24V
MI-1	72105001	Microswitch 3x22 1st speed
MI-2	72105001	Microswitch 3x22 2nd speed
MI-3	72105001	Microswitch 3x22 backwards
N	68420510	Relay 24V 20A backwards
O	68420510	Relay 24V 20A forwards
P	68420410	Relay 24V 30A Vacuum Motor
Q	68420230	Remote Control Switch 24V Double Brush Motor
R	72600006	Braking Resistors
S	72903002	Insulator M5x25 FF
T	68522070	Solenoid Coil Valve 24V - 1/2
U	72300205	Signal Lamp Red 36V, Parking
V	67903001	Battery Check Card Control
Z	72105009	Microswitch Hand Brake

Item	Part Number	Cable Descriptions
1/8	68023013	Cables and connectors for Switches
9	68023018	Cable Black No. 9
10/11	68023019	Cables Vacuum Motor No. 10-11
12	72500011	Diode and Resistance with Terminal No. 12
13	68023002	Cables and Connector Brush Release No. 13
14	68000847	Cable Brown No.14
15	68023009	Cable Black No. 15
16	68023020	Cables Connector Chopper Card No. 16
17/18	68023010	2 Cables Black-Red Brush Motor No. 17-18
19/20	68023037	2 Cables Black-Red and Connector 80A
21/22	68023038	2 Cables Black-Red and Connector 80A
23	68000154	Cable Bridge with Battery Terminals (+) (-)
24	68000892	Cable Display (Battery Signal)
25	68023021	2 Cables Black-Red Chopper Card
26	68023022	2 Cables Blue-Brown Chopper Card
28	68023025	Cable Red No. 28
31	68023039	Cable Black No. 31
33	68023040	Cable Black No. 33
39	68023026	Cable Black with Diode No. 39

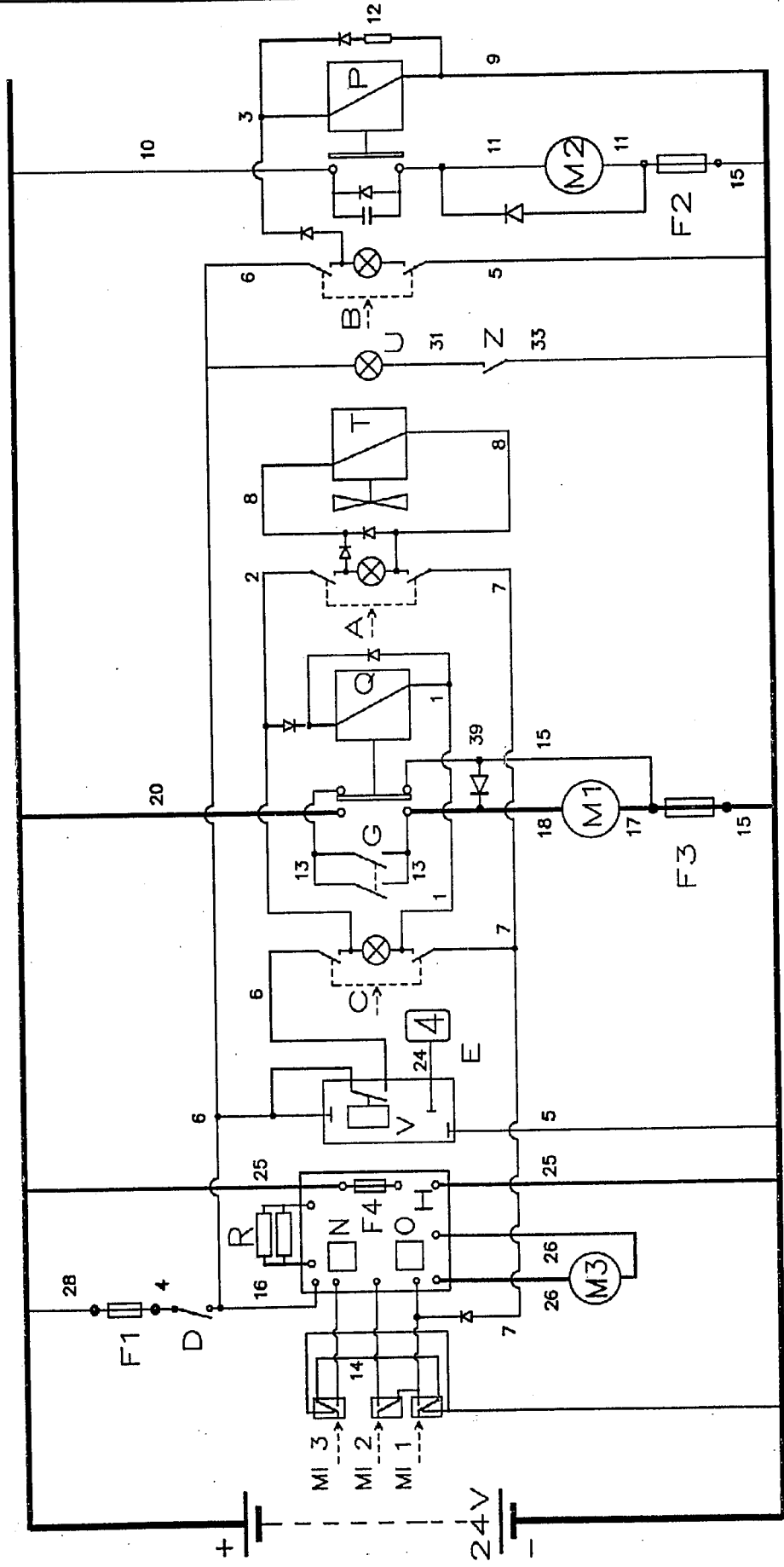

# ADJUSTMENTS & INSPECTIONS

## Inspection of the electrical layout

1. Check the functions of the electrical layout: switches, motors, solenoid valve.
2. Check the control functions and the coupling and uncoupling of the brushes.

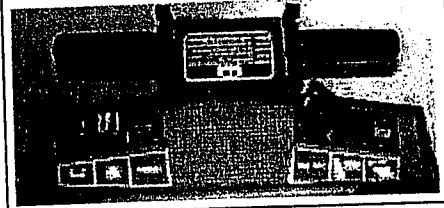

3. Control the operation of the **chopper** (Machine with traction).
4. If necessary adjust the **chopper-card** as follows:
  - a. Lift the machine (Traction wheels without contact to the floor)
  - b. Open the handlebar unscrewing the four underlying screws
  - c. Fix the clamps of the tester (V-DC) to the connections **M+** and **M-** of the chopper-card
  - d. Switch on the main key
  - e. Insert the forward gear until the **1st Microswitch** snaps (first speed)
  - f. The tester should indicate **9-10V**. If necessary adjust the **trimmer "I"** (first speed), so that the above mentioned voltage is obtained
  - g. Activate the forward gear completely, so that the **2nd microswitch** snaps. The tester must indicate **24V** (max. battery); Otherwise control the voltage of the battery and control the cables.
  - h. Acceleration adjustment: Set the **trimmer "L"** (ACC), so that its position is turned clockwise about **30°/45°** to the central position. With this adjustment you obtain the desired voltage (**9-10V** or **24V**) in about **4 seconds**.
  - i. Check the function of **reverse gear**
  - j. Check **motor braking** (after release of the handle bar the machine should stop in about 1 meter).

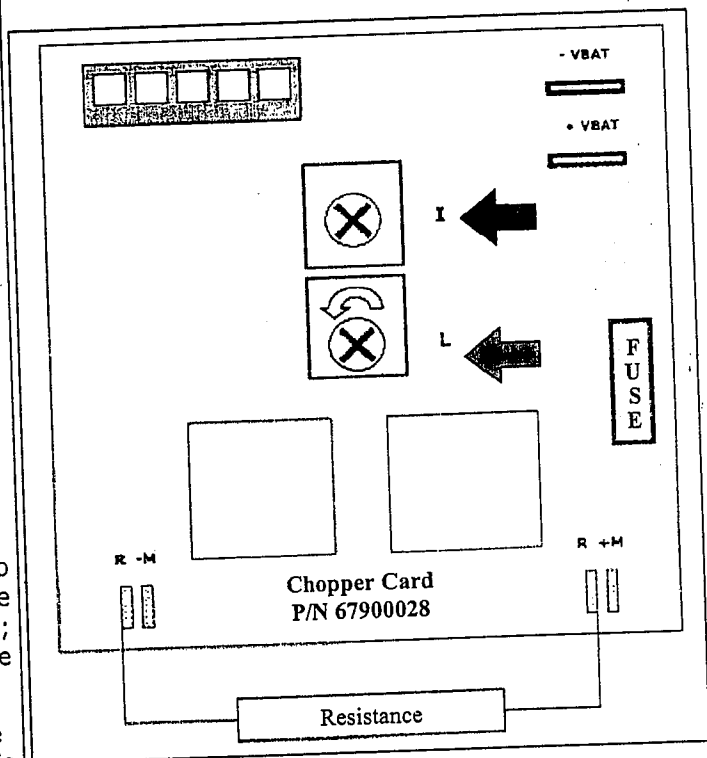

# ADJUSTMENTS & INSPECTIONS

## Inspection Water Supply

1. Check the cleanness and the positioning of the solution tank filter.

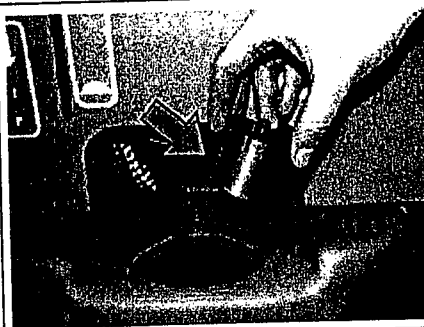

2. Fill the solution tank completely with water.
3. Check the tightness of the hoses, solenoid valve (on left) and adjustment of the water valve (on right)

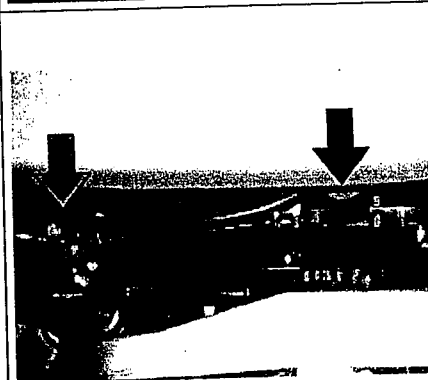

4. Make sure, that with the valve open, the solution arrives continuously on the floor.

36

## Inspection of Vacuum

1. Check the function of the filter - float.
2. Check that the cover on the recovery tank is airtight.
3. Check that the vacuum hoses and the squeegee hose are airtight.
4. Check the tightness of the squeegee opening.
5. Verify the tightness of the drain hose and drain plug.

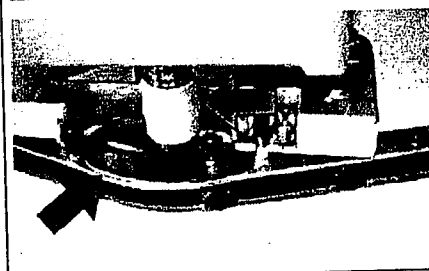
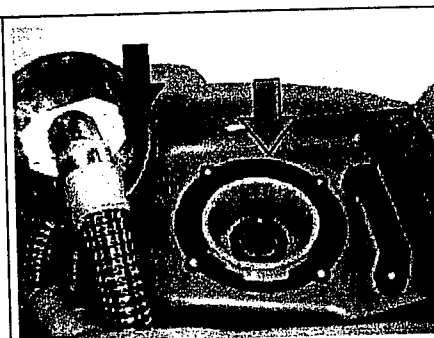

# ADJUSTMENTS & INSPECTIONS

## Brush Adjustment, 20B & 20BT – Forward movement

1. Adjust the **spring belt tightener** to a compression length of **27mm (1.06 inches)**.

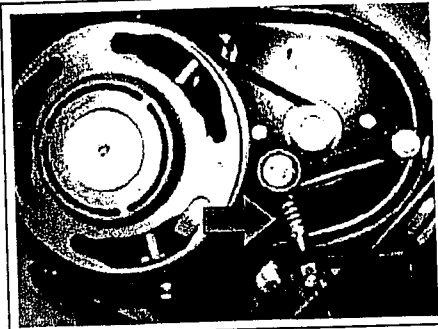
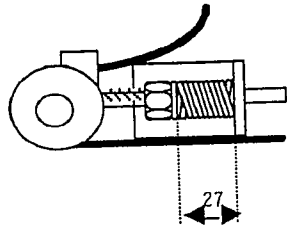

2. Inclination adjustment: Let down the brushes and adjust the distance of the **screw M8 (center)** from the brush base to about 1 mm. Then tighten the nut. Excessive screwing causes the machine to pull to the right.
3. Adjustment of advancement without traction: Screw the **knob** with the plastic thread. Attention: excessive screwing increases the traction effect but decreases the width of the cleaned floor.
4. Inclination adjustment on machine with traction: if necessary adjust the **Knob** to obtain a neutral effect.
5. Adjustment Point III: Adjust **screw M6 (upper)**, so when the brush base is lifted, an inclination about **3-4cm (1.18-1.57 in.)** on the front of the brush head is obtained. Make sure the brush motor does not touch the solution tank. Fix the **nut**.

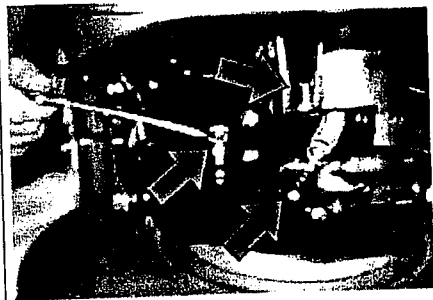

6. Adjust the **support screw (lower left)**, so that the weight of the tank doesn't rest completely on the frame; fix the nut.
7. Tie rods: adjust the fork of the **vertical tie rod**, so that when the brush is lifted there are no interferences with the tank.
8. Adjust the fork of the **horizontal tie rod** and do not allow the lift arms of the brush base to touch the frame, also, the brush cover should not contact the solution tank. Furthermore check, that without brushes the brush holder is 0-1 mm from the floor.



9. Confirm the **screw with the round head rests on the plain top of the brushes**. The play between the head and brush must be maximally 1-2mm with coupled brushes and lowered brush head.





# ADJUSTMENTS & INSPECTIONS

## Cylindrical brush head adjustment

Adjustment of the brush head - lifted: to get the correct height when the brush head is lifted, adjust the *two forks* on the rear and underneath the solution tank.

The correct inclination of the brush head is automatically correct after the adjustment of *the screw* (next picture, top arrow) to obtain good brush tracks on the floor (see the following paragraphs)

### Adjustment of the brush head - lowered:

To get the same width of the brush tracks on the floor: adjust *the screw* (top arrow) that permits to equilibrate the balanced distribution of the weight (motor on the front).

To adjust the brush pressure on the floor: adjust *the knob* (right arrow) on the threaded rod connected to the frame by a spring. The spring's action reduces the brush pressure on the floor.

Check the track work on the floor for 30 seconds without water.

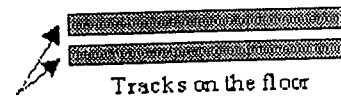
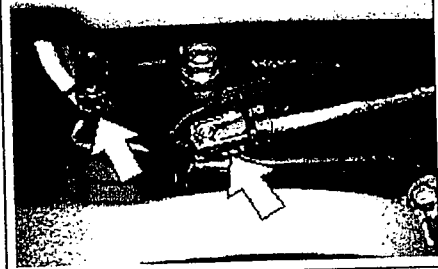

## Brake adjustment

1. Adjustment hand brake: Verify the **lever** does not release more than 3-4 times. If necessary restore the correct range by adjusting the nut on the brake cable.
2. Adjustment of brake pads: Verify uniform brake effect. Try to turn the machine both left and right with the brake inserted: Checking that the wheels remain blocked in the same way.

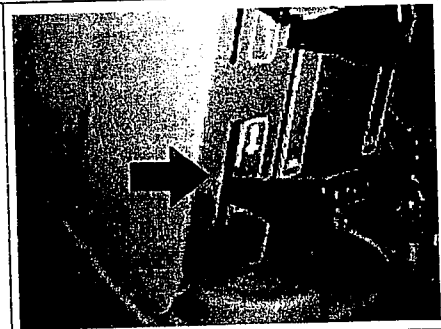

# ADJUSTMENTS & INSPECTIONS

## Adjustment Squeegee

1. Adjust the the inclination **controller (on left)** of the rear squeegee rubber while using to obtain a uniform inclination.
2. Adjust the wheel height with the **hand wheel (on right)** checking that the rubber has an inclination about 30°-45° and is not pressed down too much on the floor nor lifted too much.

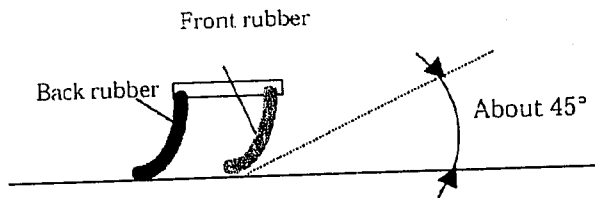

3. Adjust lifting cable length with the corresponding controller, until the back rubber is lifted about 4-5 cm (1.57-1.97 inches) from the floor. The squeegee should not have contact with the tank outlet. Afterwards fix the nut.

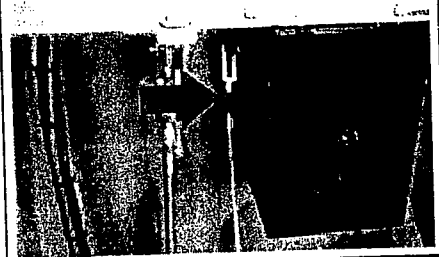

4. Check that the **Spring ring** is completely closed.

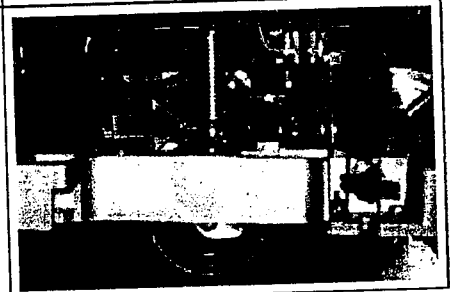

## Final inspection

Check all functions: scrubbing, suction, forward- and reverse gear and emergency brake.

## WARRANTY POLICY PACIFIC LIMITED WARRANTY

This Pacific Steamex and Floorcleaner have been manufactured, tested and inspected in accordance with specific engineering requirements. This machine is **WARRANTED** to be free from defects in workmanship and materials for periods as follows from the date of purchase.

Ten (10) Years Parts, One (1) Year Labor – Polyethylene Components  
Five (5) Years Parts, One (1) Year Labor – Main Frame

Two (2) Years Parts, One (1) Year Labor – Brush Drive Motors  
One (1) Year Parts & Labor – All other components unless excluded below

The limited free warranty repair is provided for a period of ninety (90) days following the date of sale to the end user, with a maximum of three (3) hours per claim.

This warranty extends to the original user/purchaser and only when used, operated and maintained in accordance with Pacific Operating and Maintenance instructions.

This warranty does not apply to certain wear parts and accessories of the machine such as electrical cords, carbon motor brushes, floor brushes, belts, hoses, tools, squeegee blades, etc., nor does it apply to damage or failure caused by improper use, abuse or neglect. Warranty credit or replacement of return parts including motors, pumps, etc., is subject to incoming inspection of those items.

To secure repair under this warranty, the following procedure should be taken:

1. After the expiration of the ninety (90) day travel time warranty period, the customer is responsible for warranty travel payment or the inoperative machine or warranted parts must be delivered to the authorized dealer with shipping and delivery charges prepaid. If unable to locate the Dealer, you may contact Pacific at the address listed herein for the location of the nearest Pacific repair center or agent or for other instructions pertaining to your warranty difficulty.
2. Upon compliance with the above warranty procedure, all warranted repairs will be completed at no additional charge or cost to the user.
3. Only Pacific or its authorized dealers and agents may make no charge warranty repairs on this product. All others do so at their own risk.

This warranty limits Pacific liability to the repair of the product and/or warranted parts replacement and does not include incidental or consequential damages arising from the use of a Pacific machine whether defective or not.

### BATTERY WARRANTY

In addition to the terms above, any original equipment Pacific Steamex Battery which becomes unserviceable under normal use within a period of ninety (90) days from date of sale to the original user will be repaired or replaced with one of equal specification at our option, F.O.B. any authorized Pacific or Service Branch, with no charge to user, except transportation costs. After the expiration of the above ninety (90) day period, any battery which fails under normal use will be adjusted to the original user with a new battery of equal specification on a twelve (12) month pro rata basis from the date of purchase. Adjustment will be determined using the then current list price, plus transportation costs. Warranty is rendered null and void if battery is not kept filled to the proper level with **DISTILLED WATER**.

This warranty is in lieu of all other expressed or implied warranties and is extended to the original purchaser/user.

# PACIFIC

2259 Sheridan

Muskogon, Michigan 49442

Ph: (800) 968-1332 Fax: (231) 773-1642

[www.nextwaveofclean.com](http://www.nextwaveofclean.com)