

ScrubMaster 210

Parts List

The contents of this manual are based on the latest product information available at the time of publication. Pacific Steamex reserves the right to make changes or improvements to its machines without notice.

For new books write to:

Pacific
2259 S. Sheridan
Muskegon, MI 49442-6252

Carefully inspect all components to ensure that there is no concealed freight damage. If such damage is discovered, file a "CONCEALED DAMAGE REPORT" immediately with the delivering carrier.

FOR YOUR CONVENIENCE, RECORD THE FOLLOWING IMPORTANT INFORMATION:

MODEL _____

SERIAL NUMBER _____

PART NUMBER _____

DATE PURCHASED _____

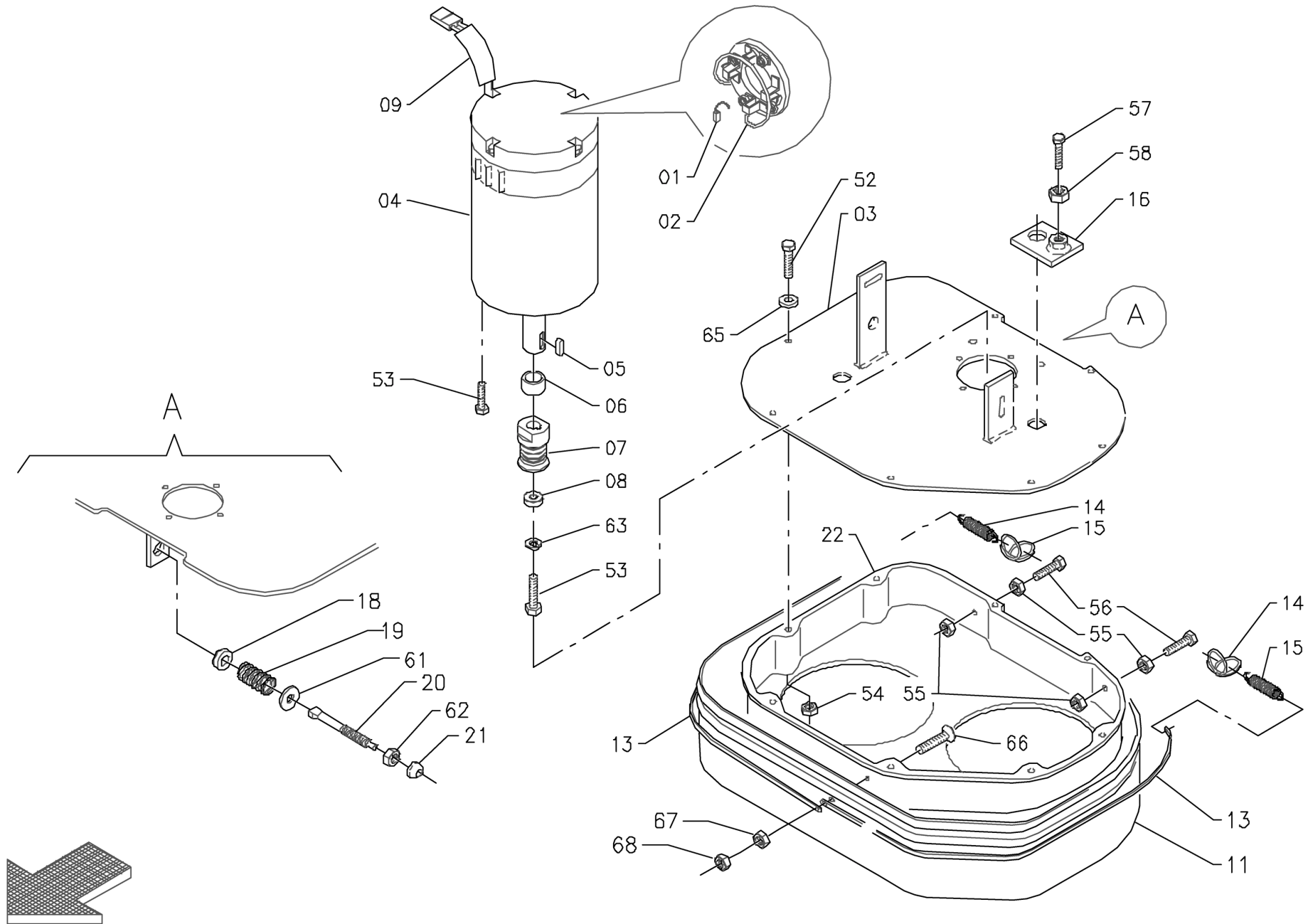

DRAWING 01A

Item	Part Number	Description	Qty.
1	71707141	Carbon Brush Motor	4
2	72901029	Carbon Brush Holder	1
3	69824020	Brush Base	1
4	68220410	Motor Complete	1
5	885030	Key	1
6	69023020	Spacer	1
7	69420120	Pulley	1
8	40504040	Special Washer	1
9	67404160	Sheath	1
11	67624020	Splash Guard	1
13	41301040	Blade	2
14	887350	Ring	2
15	888336	Spring	2
16	41501010	Plaque	1
18	69104030	Bushing	1
19	69210020	Spring	1
20	40501080	Adjuster	1
21	69104040	Bushing	1
22	41301050	Base Cover	1
52	70910503	Screw	
53	964116	Screw	
54	924032	Lock Nut	
55	71060501	Nut	
56	70910508	Screw	
57	70911006	Screw	
58	924053	Nut	
61	980064	Washer	
62	924055	Lock Nut	
63	71106009	Lock Washer	
65	980066	Washer	
66	70970405	Screw	
67	924045	Nut	
68	924029	Nut	

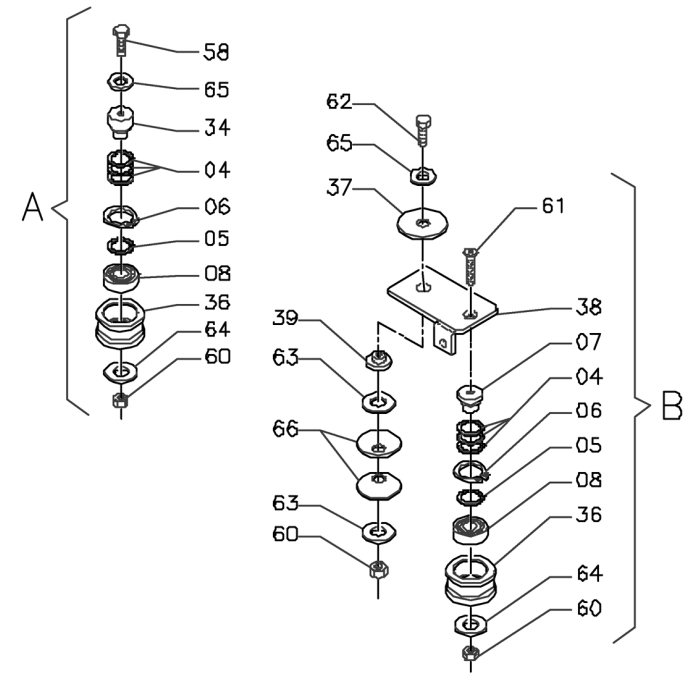
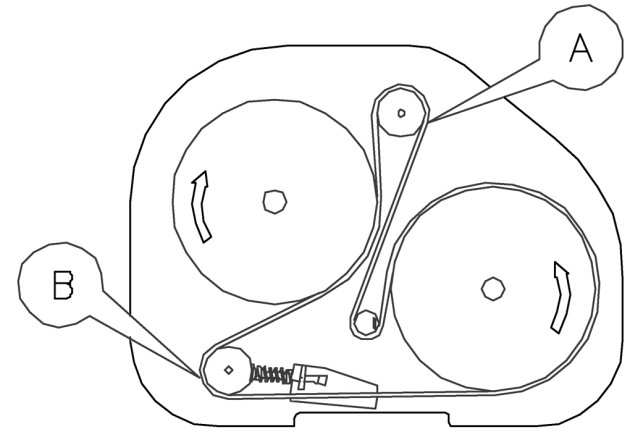
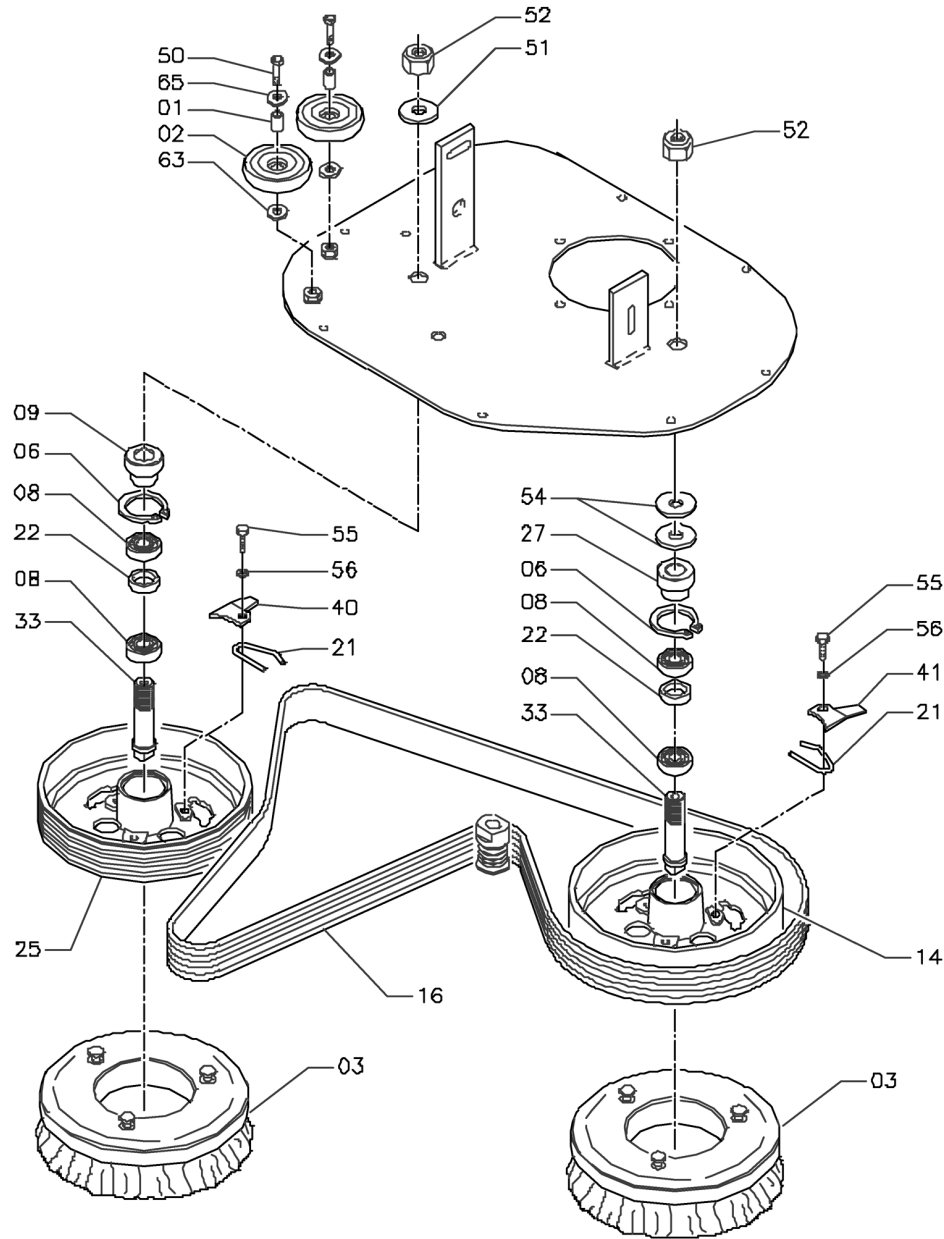

DRAWING 02A

Item	Part Number	Description	Qty.
1	69102110	Bushing	2
2	67020030	Wheel	2
3	66808040	Brush	2
4	71228001	Shim	6
5	71247002	Shim	2
6	70210004	Seeger Ring	4
7	40801020	Pin	1
8	902033	Bearing	6
9	40501110	Spacer	1
14	69430100	Pulley	1
16	881352	Belt	1
21	69230310	Spring	2
22	69007010	Spacer	2
25	69420150	Pulley	1
27	69012010	Spacer	1
33	40501010	Shaft	2
34	40801030	Pin	1
36	69430150	Pulley	2
37	40501050	Washer	1
38	40501040	Arm	1
39	69104020	Bushing	1
40	41301100	Plaque	1
41	41301090	Plaque	1
50	70910834	Screw	
51	980068	Washer	
52	71022001	Lock Nut	
54	71120001	Washer	
55	964121	Screw	
56	980053	Lock Washer	
58	964084	Screw	
60	924033	Lock Nut	
61	70980812	Screw	
62	70910834	Screw	
63	980044	Washer	
64	980070	Washer	
65	980039	Washer	
66	71308004	Washer	

BRUSH CONTROL ASSEMBLY

03

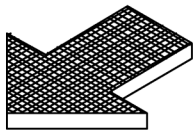
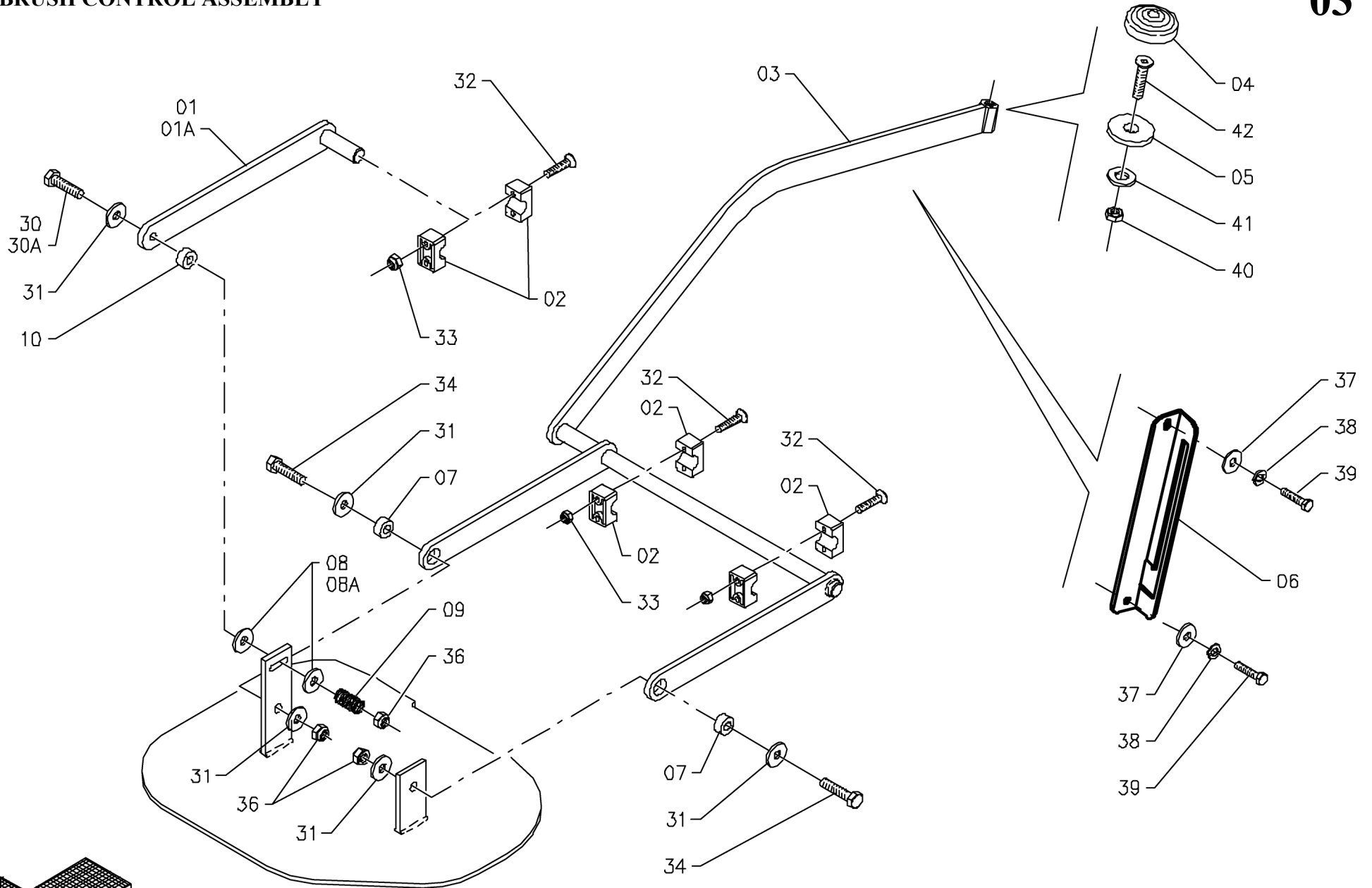

DRAWING 03

Item	Part Number	Description	Qty.
1	42403020	Arm	1
2	882043	Holdfast	8
3	42403010	Arm	1
4	42218020	Pedal Cover	1
5	42403050	Pedal	1
6	42403030	Guide	1
7	69105100	Bushing	2
8	71108010	Washer	2
9	69210360	Spring	1
30	70910813	Screw	
31	980044	Washer	
32	70970605	Screw	
33	924026	Lock Nut	
34	964085	Screw	
36	924033	Lock Nut	
37	980040	Washer	
38	71106009	Lock Washer	
39	964107	Screw	
40	924035	Nut	
41	980064	Washer	
42	70980802	Screw	

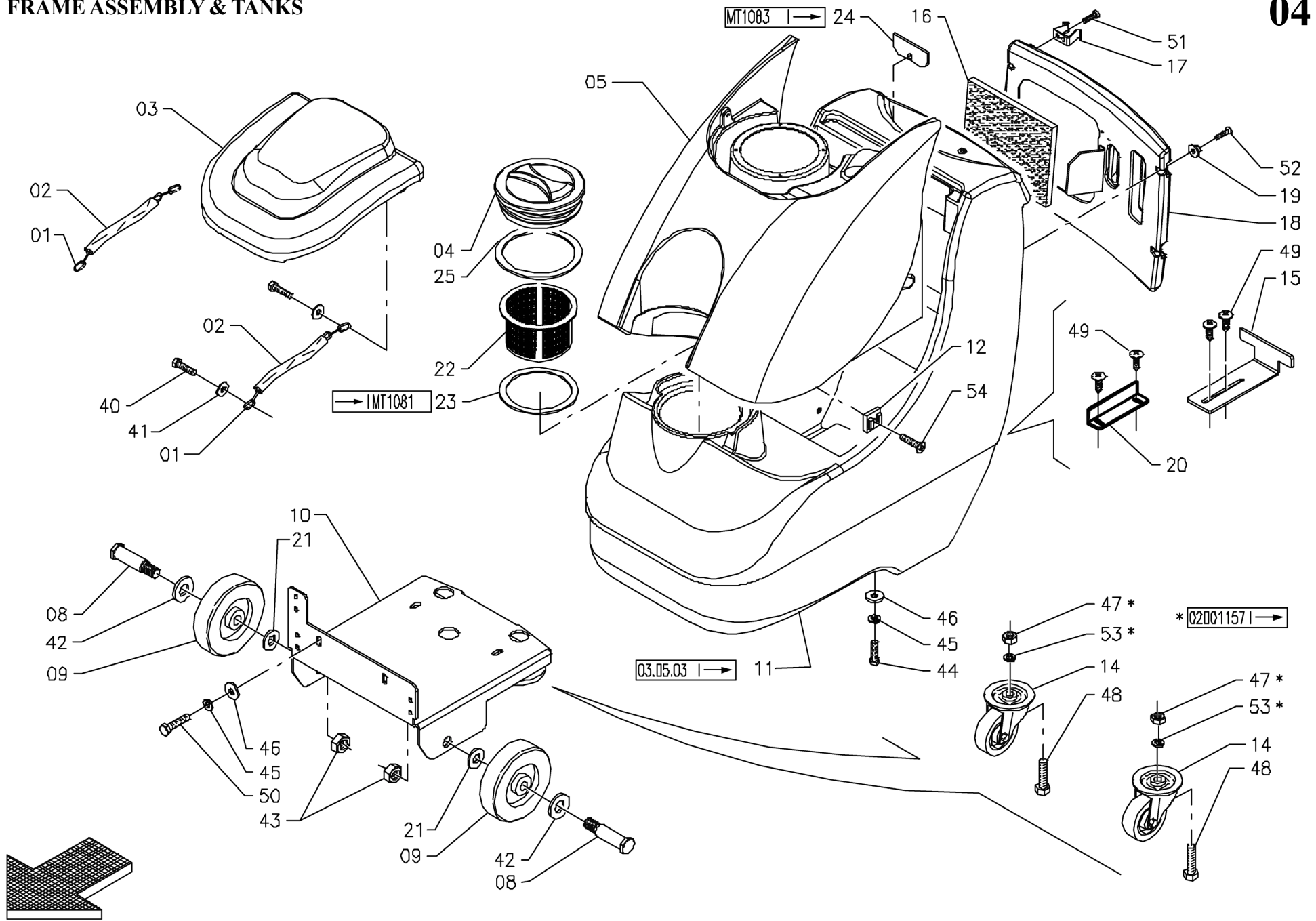

DRAWING 04

Item	Part Number	Description	Qty.
1	42436010	Chain	2
2	67404280	Hose	2
3	42446020	Cover	1
4	886844	Cover	1
5	69724040	Recovery Tank	1
8	42417010	Center Line	2
9	67010300	Wheel	2
10	69924100	Frame	1
11	69724030	Solution Tank	1
12	74400019	Support Plate	4
14	67050110	Caster Wheel	2
15	42451010	Angle	1
16	67101500	Deadening	1
17	882440	Hook	1
18	42446010	Panel	1
19	980621	Special Washer	4
20	42451030	Stop	1
21	69007010	Spacer	2
22	66500140	Filter	1

Item	Part Number	Description	Qty.
23	67406230	Ring	1
24	67400240	Gasket	2
25	67401080	Gasket	1
40	964065	Screw	
41	980071	Washer	
42	980068	Washer	
43	71021601	Lock Nut	
44	964116	Screw	
45	71106009	Lock Washer	
46	71106006	Washer	
47	71011202	Lock Nut	
48	70911202	Screw	
49	70945501	Screw	
50	70910612	Screw	
51	70944203	Screw	
52	70950502	Screw	
53	71112004	Washer	
54	964063	Screw	

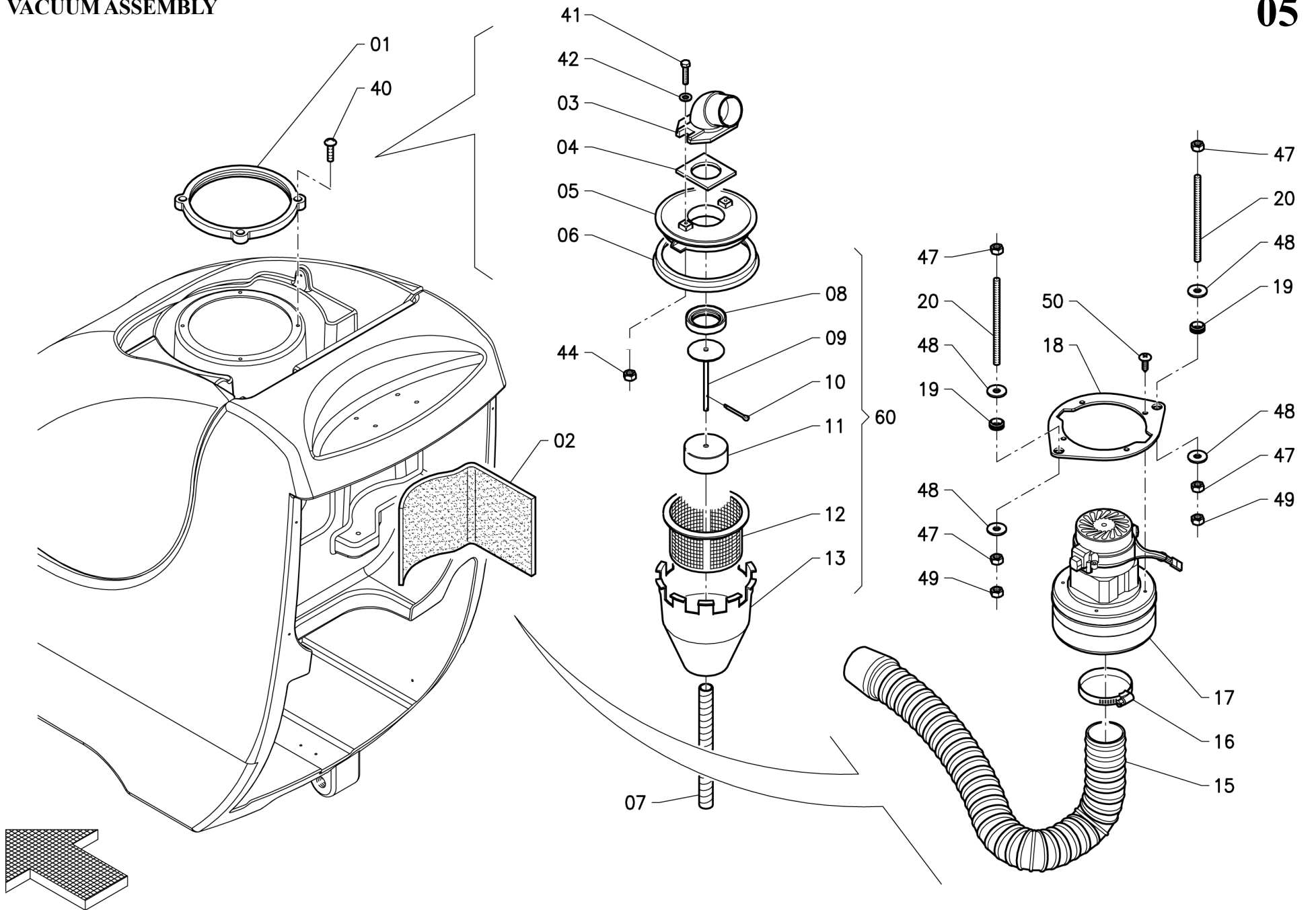

DRAWING 05

Item	Part Number	Description	Qty.
1	42036030	Filter Holder	1
2	67101490	Deadening	1
3	882442	Opening	1
4	883446	Gasket	1
5	886841	Cover	1
6	883441	Gasket	1
7	67522840	Hose	1
8	883442	Gasket	1
9	887440	Rod	1
10	925603	Split Pin	2
11	883344	Float	1
12	883343	Filter	1
13	888551	Protection	1
15	67512670	Vacuum Hose	1
16	882041	Clamp	1
17	68130510	Vacuum Motor	1
18	42441010	Plaque	1
19	883830	Fairlead	2
20	40136010	Stud Bolt	2
40	964063	Screw	
41	70950502	Screw	
42	980621	Washer	
44	71020502	Lock Nut	
47	924026	Lock Nut	
48	980042	Washer	
49	924063	Nut	
50	70944801	Screw	
60	A6520001	Float Assembly	1

WATER UNIT

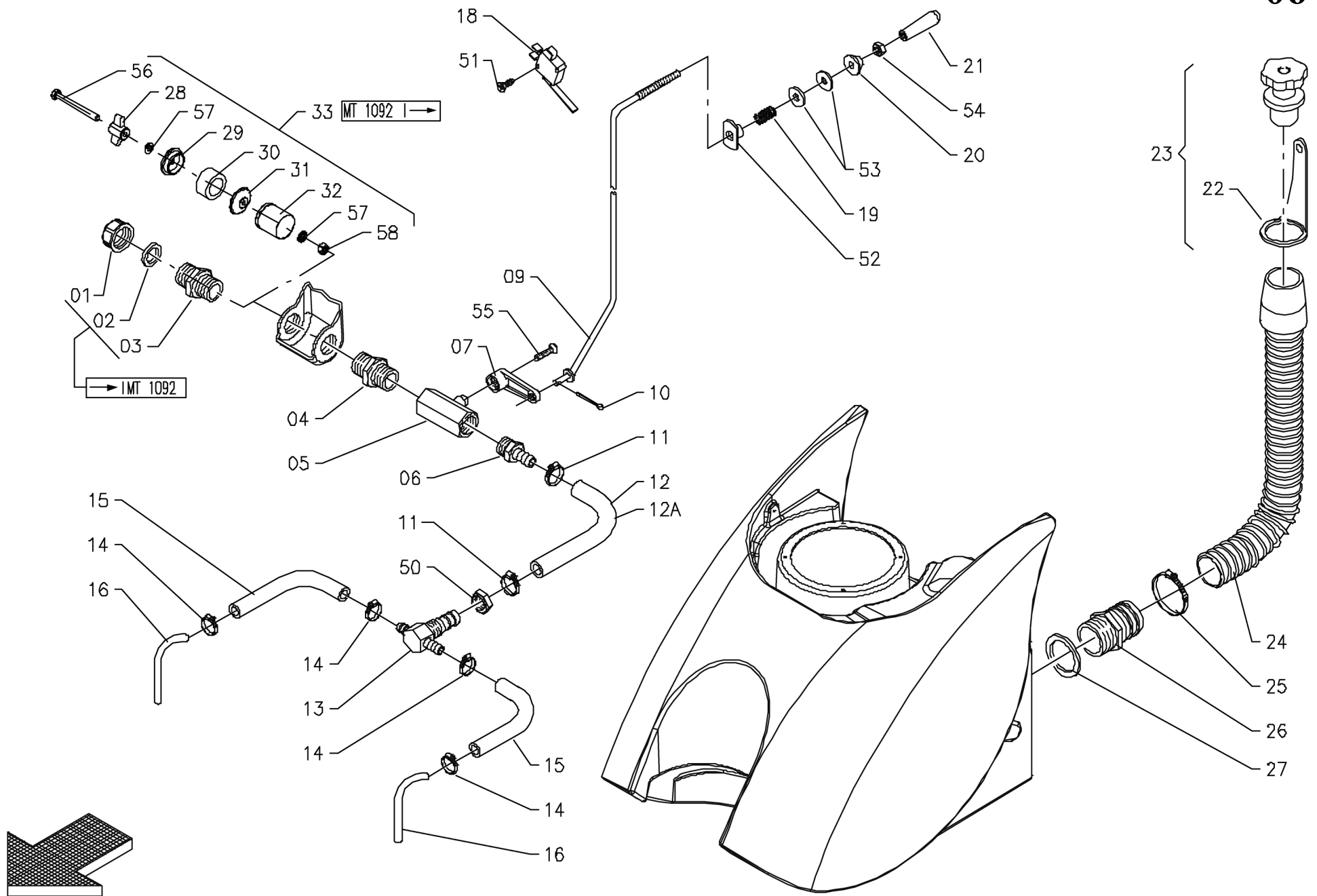

DRAWING 06

Item	Part Number	Description	Qty.
1	74550009	Cap	1
2	67400640	Gasket	1
3	74560004	Nipple	1
4	74560023	Nipple	1
5	889440	Valve	1
6	74540014	Fitting	1
7	42437020	Lever, Valve	1
9	42437010	Rod	1
10	71600003	Spring	1
11	74220061	Clamp	2
12	67523400	Pipe	1
13	41337030	Fitting	1
14	74210004	Clamp	4
15	67523370	Pipe	2
16	42401010	Pipe	2
18	72105009	Microswitch	1
19	69210360	Spring	1
20	980621	Special Washer	1
21	885044	Knob	1
22	42341010	Clamp	1

Item	Part Number	Description	Qty.
23	42436030	Plug for Drain Hose	1
24	67512580	Drain Hose	1
25	882041	Clamp	1
26	74540036	Connector	1
27	67406180	Gasket	1
28	74006012	Wing Nut	1
29	40136040	Bottom of Exhaust Plug	1
30	42437050	Rubber Ring	1
31	42437060	End of Threaded Plug	1
32	66500540	Filter	1
33	A6524002	Filter Assembly	1
50	71011402	Nut	
51	70942901	Screw	
52	71070501	Nut	
53	980061	Washer	
54	924046	Nut	
55	964127	Screw	
56	70910623	Screw	1
57	980062	Washer	2
58	924050	Nut	1

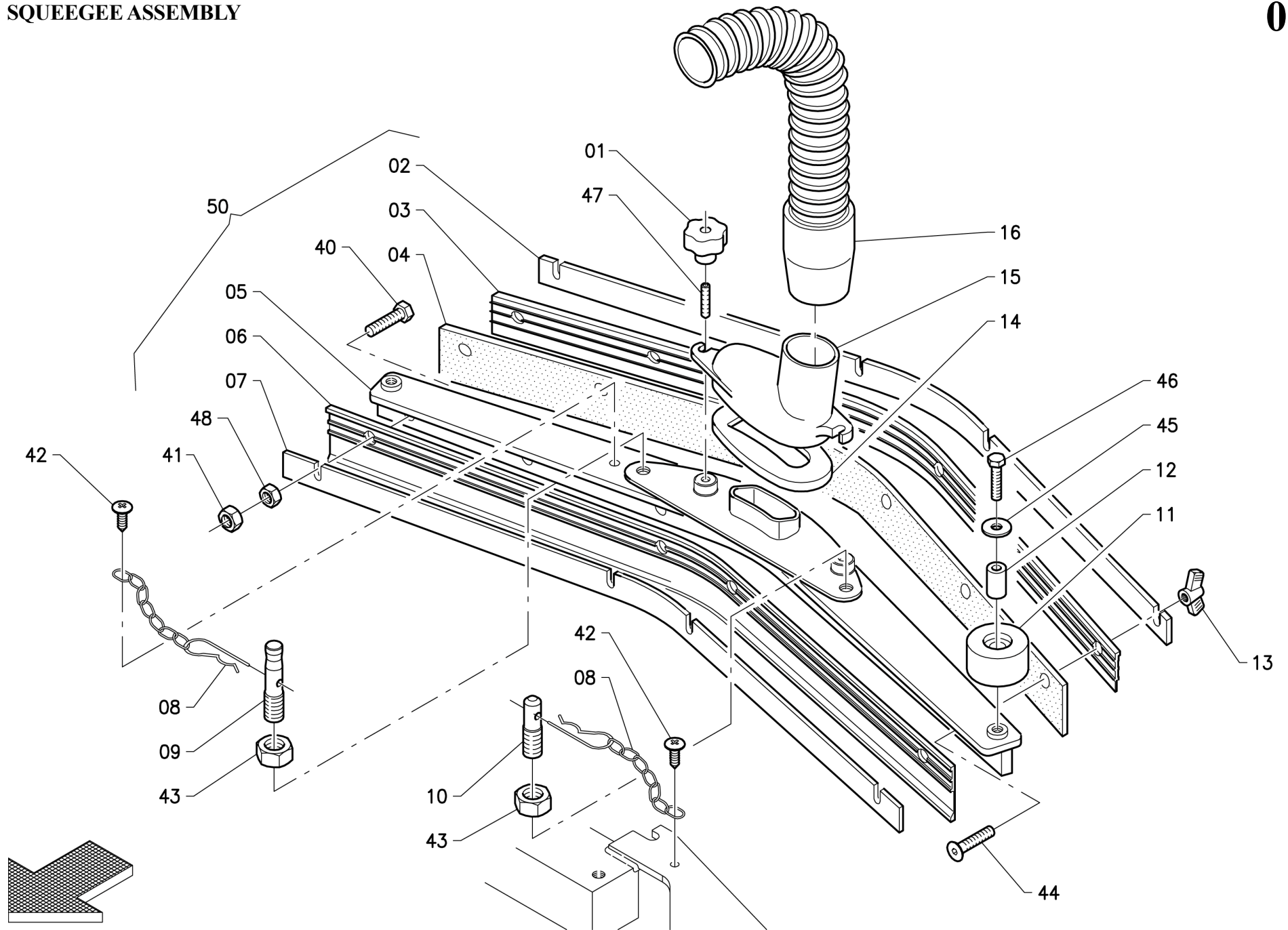

DRAWING 07

Item	Part Number	Description	Qty.
1	885046	Knob	2
*2	68820020	Blade	1
*3	67720010	Rear Rubber	1
*4	67720030	Central Rubber 33 Shore	1
*5	69620020	Squeegee Body	1
*6	880742	Front Rubber	1
*7	68820010	Blade	1
8	882444	Chain	2
9	40111050	Stud Bolt	1
10	42411010	Stud Bolt	1
11	889742	Wheel	2
12	881145	Bushing	2
13	74006011	Wing Nut	6
14	67406190	Gasket	1
15	880240	Opening	1
16	67512410	Vacuum Hose	1
*40	964109	Screw	
*41	924050	Lock Nut	
42	70945501	Screw	
43	924053	Nut	
44	964110	Screw	
45	980039	Washer	
46	964085	Screw	
47	925606	Dowel	
*48	924054	Nut	
*50	A9624001	Squeegee Assembly	

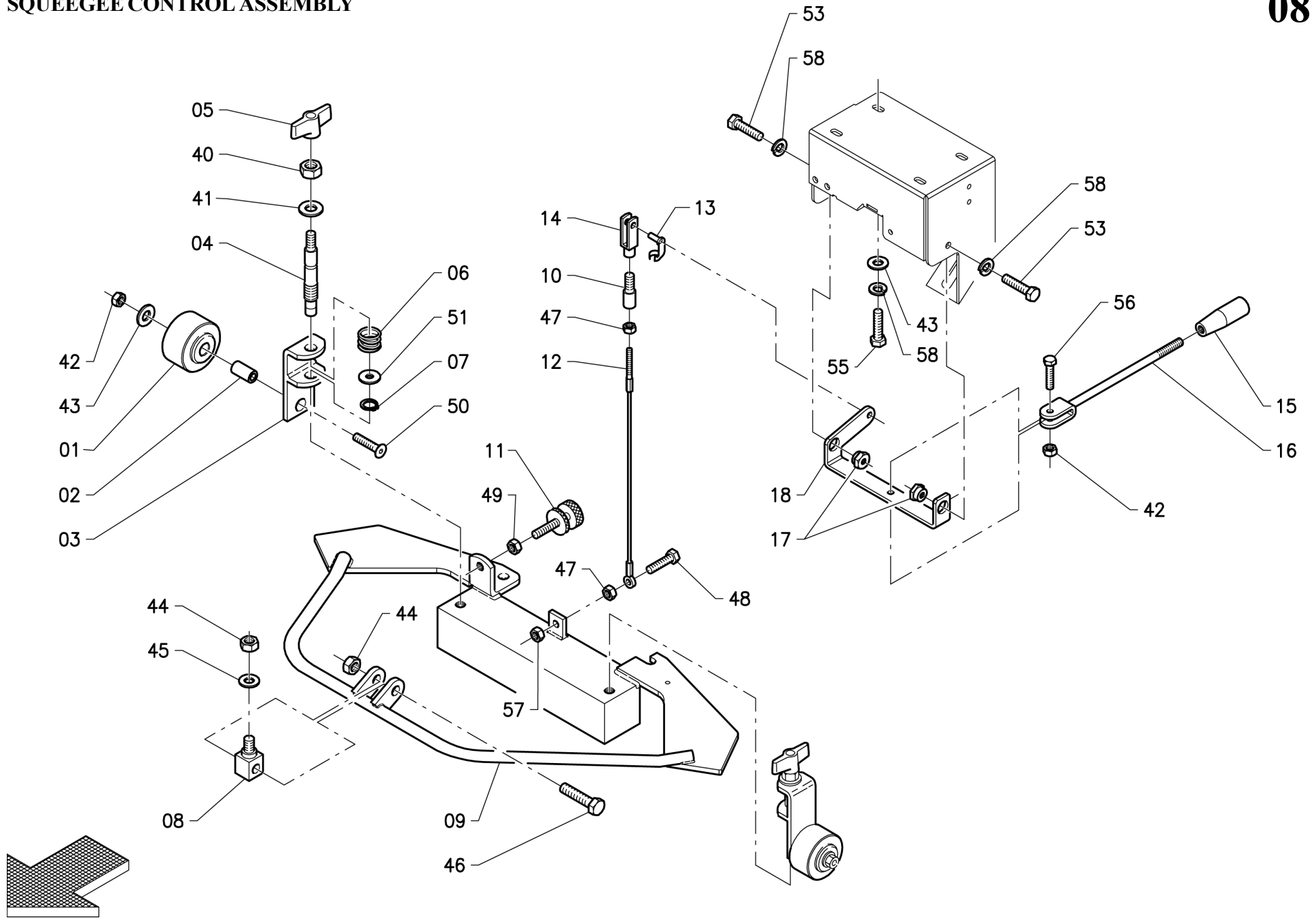

DRAWING 08

Item	Part Number	Description	Qty.
1	67010030	Wheels	2
2	69100040	Bushing	2
3	42012080	Support	2
4	42012070	Pin	2
5	74008005	Knob	2
6	69210530	Spring	2
7	887341	Seeger Ring	2
8	42412020	Block	1
9	42412030	Coupling	1
10	42312130	Extension Tube	1
11	40112040	Adjuster	1
12	41312150	Cable	1
13	74620008	Pin	1
14	74610007	Fork	1
15	74100051	Knob	1
16	42412070	Lever	1
17	69123010	Bushing	2
18	42412040	Lever	1
40	71010804	Nut	
41	980039	Washer	
42	924026	Lock Nut	
43	980040	Washer	
44	924055	Lock Nut	
45	924030	Washer	
46	70911015	Screw	
47	924046	Nut	
48	964065	Screw	
49	924035	Nut	
50	70970605	Screw	
51	980046	Washer	
53	70910605	Screw	
55	964107	Screw	
56	964116	Screw	
57	924032	Lock Nut	
58	71106009	Lock Nut	

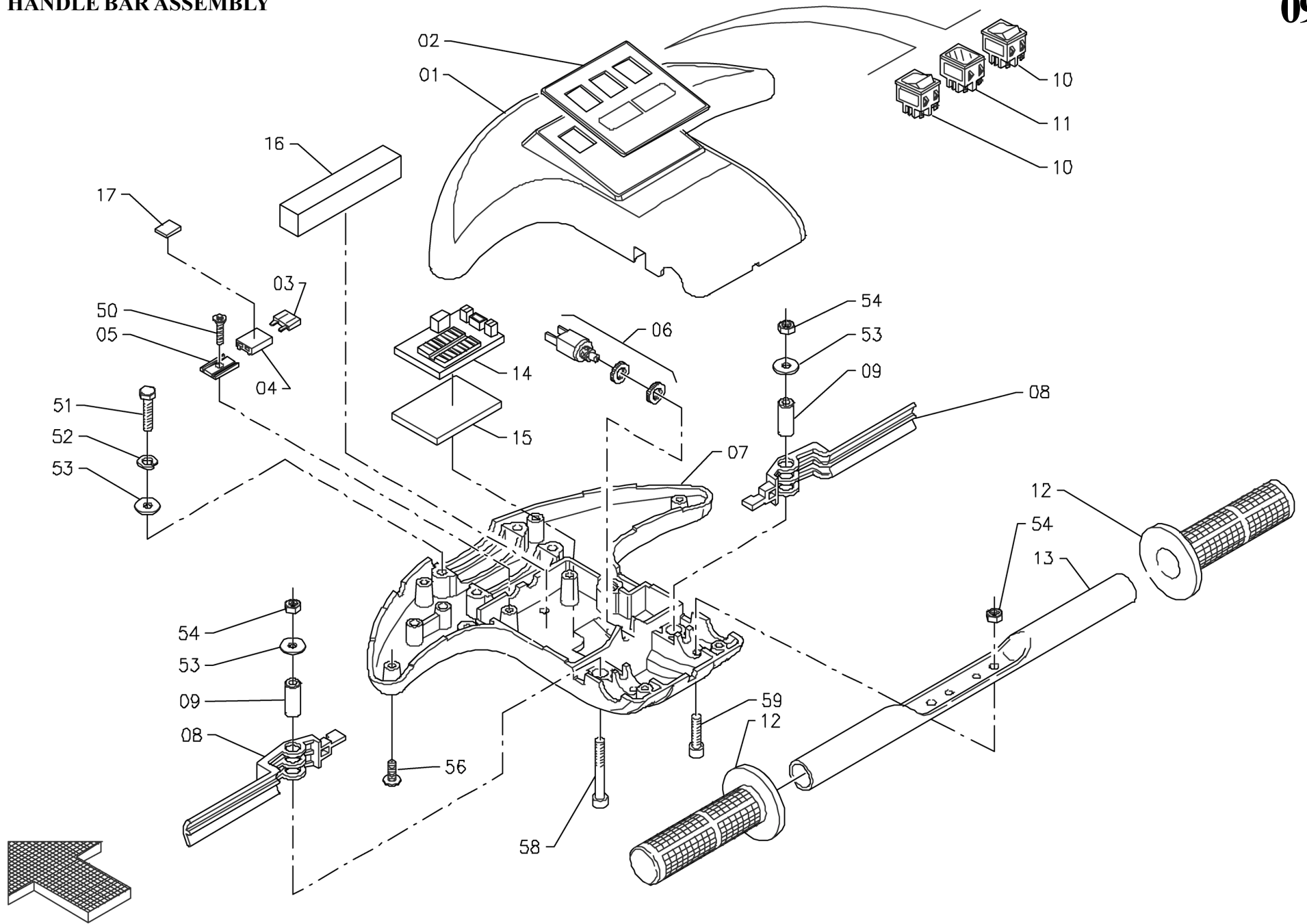

DRAWING 09

Item	Part Number	Description	Qty.
1	42446040	Handle Bar Cover	1
2	66401360	Decal	1
3	72400301	Fuse	1
4	72400011	Fuseholder	1
5	72916001	Plaque	1
6	72105016	Microswitch	1
7	42426030	Handle Bar Body	1
8	42426020	Lever	2
9	69023010	Pin	2
10	911172	Switch	2
11	72300117	Battery Warning Light	1
12	74100017	Handle Grip	2
13	42426010	Pipe	1
14	67903001	Battery Chack Card	1
15	67401100	Gasket	1
16	67402210	Spacer	1
50	70944201	Screw	
51	964079	Screw	
52	71106009	Lock Washer	
53	980040	Washer	
54	924026	Lock Nut	
56	964063	Screw	
58	70930607	Screw	
59	70930601	Screw	

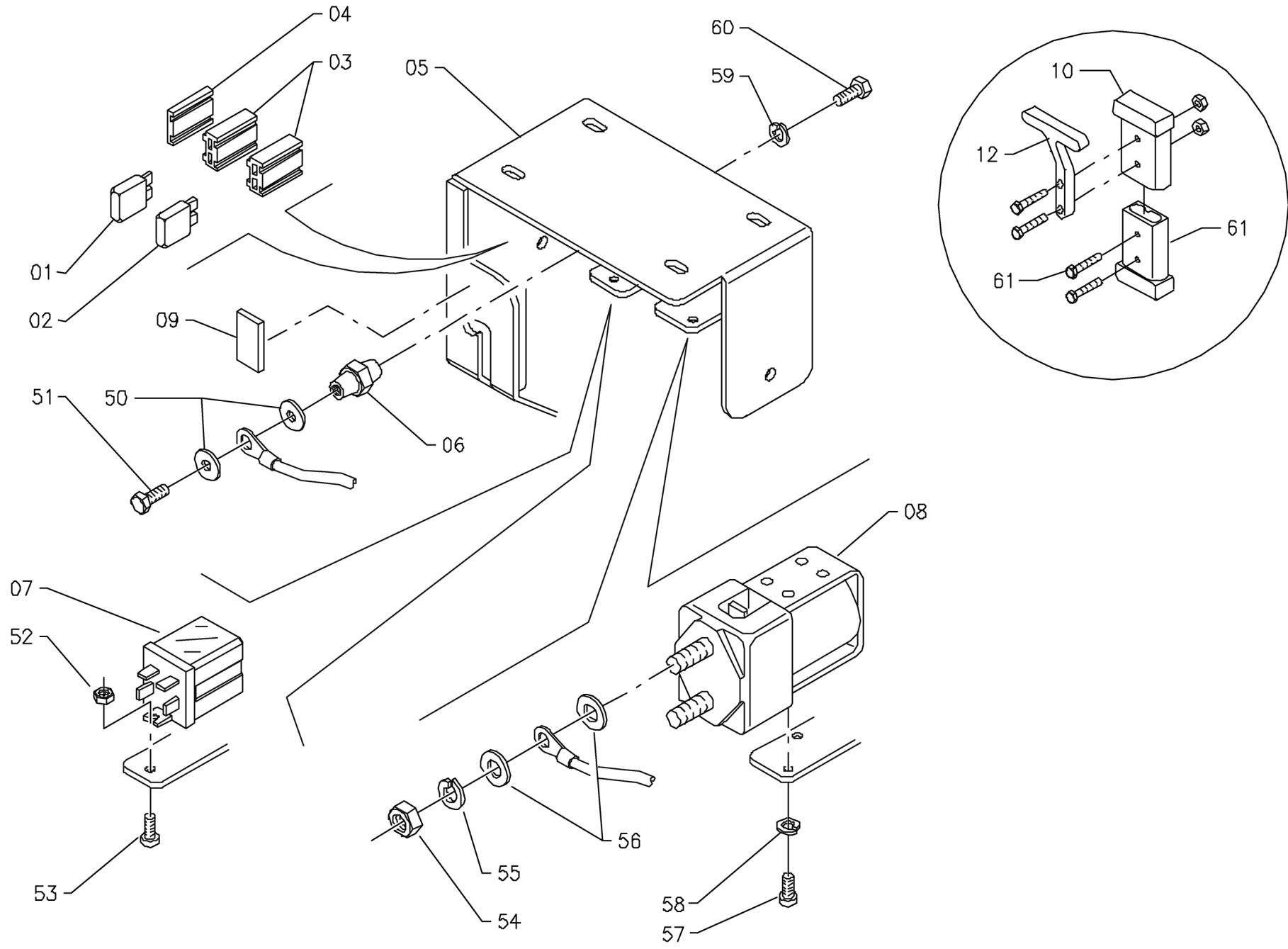

DRAWING 10

Item	Part Number	Description	Qty.
1	72405002	Fuse 50A	1
2	72403003	Fuse 30A	1
3	72400012	Fuseholder	2
4	72916004	Plaque	1
5	42412050	Coupling	1
6	72903002	Insulator	1
7	887550	Relay	1
8	68420110	Remote Control Switch	1
10	72700011	Connector, Male - 50 Amp	1
11	72700012	Connector, Female - 50 Amp	1
12	72700029	Lever for Connector	1
50	980071	Washer	
51	964082	Screw	
52	924029	Lock Nut	
53	964098	Screw	
54	71010805	Nut Brass	
55	980069	Washer	
56	71108004	Washer	
57	964127	Screw	
58	980058	Lock Washer	
59	71105006	Washer	
60	70910508	Screw	
61	70943906	Screw	

Electrical Diagram - LEAD ACID Batteries

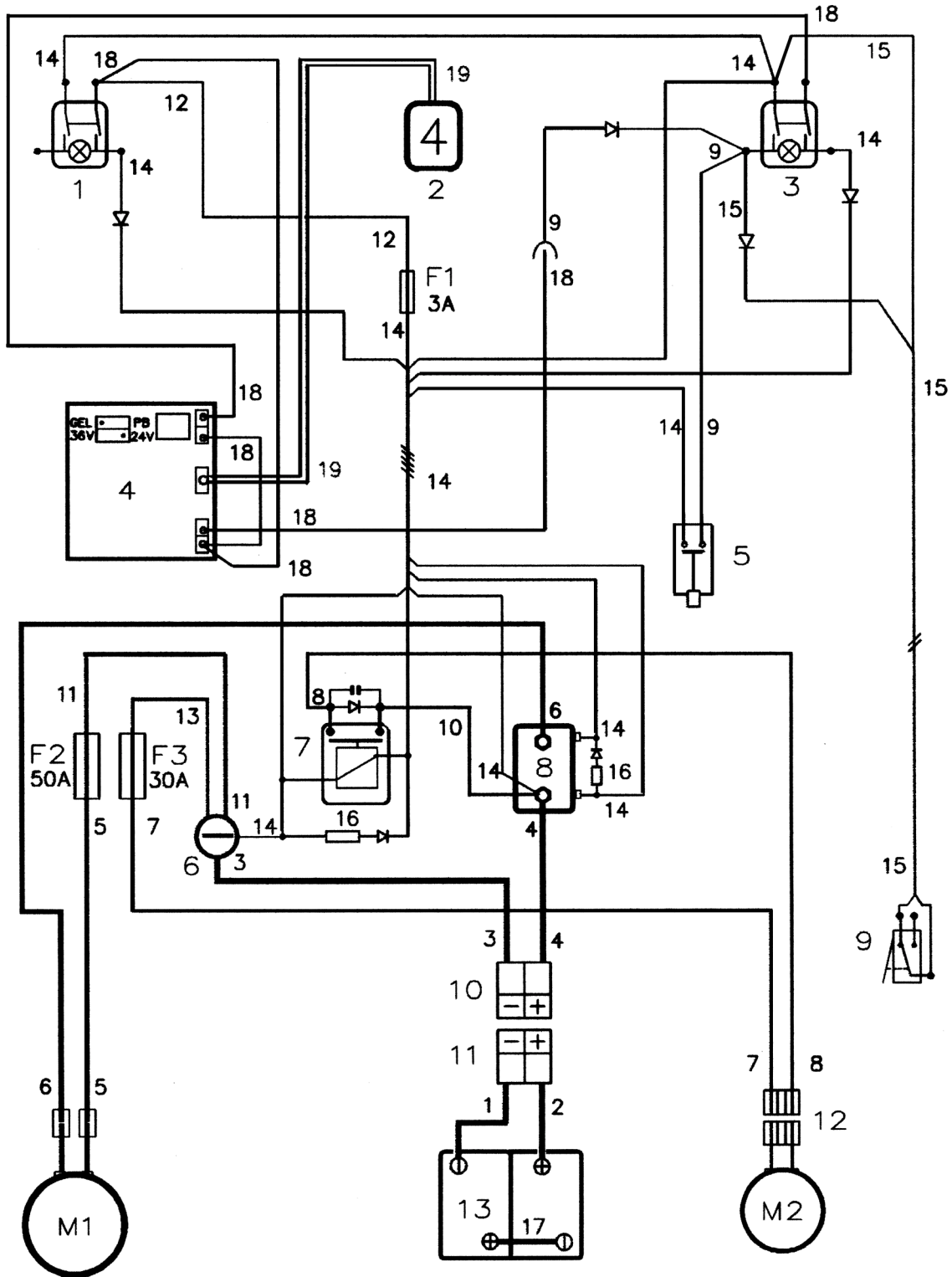

Electrical Parts List - LEAD ACID Batteries

Components

Item	Part Number	Description
1	911172	Bipolar Switch Green 24V Vacuum Motor
2	72300117	Battery Signal Lead/Water Valve
3	911172	Bipolar Switch Green 24V Brush Motor
4	67903001	Battery Check Card
5	72105016	Microswitch Start Brushes
6	72903002	Insulator
7	887550	Relay 24V 30A Vacuum Motor
8	68420110	Remote Control Switch 24V-100A Brush Mtr.
9	72105009	Microswitch Water Valve
10	72700011	Connector Male 50A
11	72700012	Connector Female 50A
12	72700007	Double Connector 30A Vac Motor
13	881347	Lead Acid Batteries, 100 AH/12 Volt - 2 required
M1	68220410	Brush Motor 24V
M2	68130510	Vacuum Motor
F1	72400301	Fuse 30A Faston General Key
F2	72405002	Fuse 50A Faston Brush Motor
F3	72403003	Fuse 30A Faston Vacuum Motor

Cables

Item	Part Number	Description
1-2	68024001	Cable Black-Red + Battery Terminals + 50A Connector
3-4	68024002	Cable Black-Red + 50A Connector
5-6	68024003	Cable Black-Red with Couplings
7-8	68024004	Cable Black-Red with 30A Connector
9	68024005	2 Cables Green
10	68024006	Cable Red with Diode and Condenser
11	68024007	Cable Black
12	68024018	Cable Red
13	68024009	Cable Black
14	68024010	Cable 5x1 + Black Bridges
15	68024011	2 Cables Blue-Brown
16	72500011	Diode and Resistances with Terminal
17	68024013	Cable Black Battery Bridge
18	68024017	3 Cables Black-Red-Green+Connector+Bridge
19	68000892	Cable Display Battery Signal

Functional Schematic - LEAD ACID Batteries

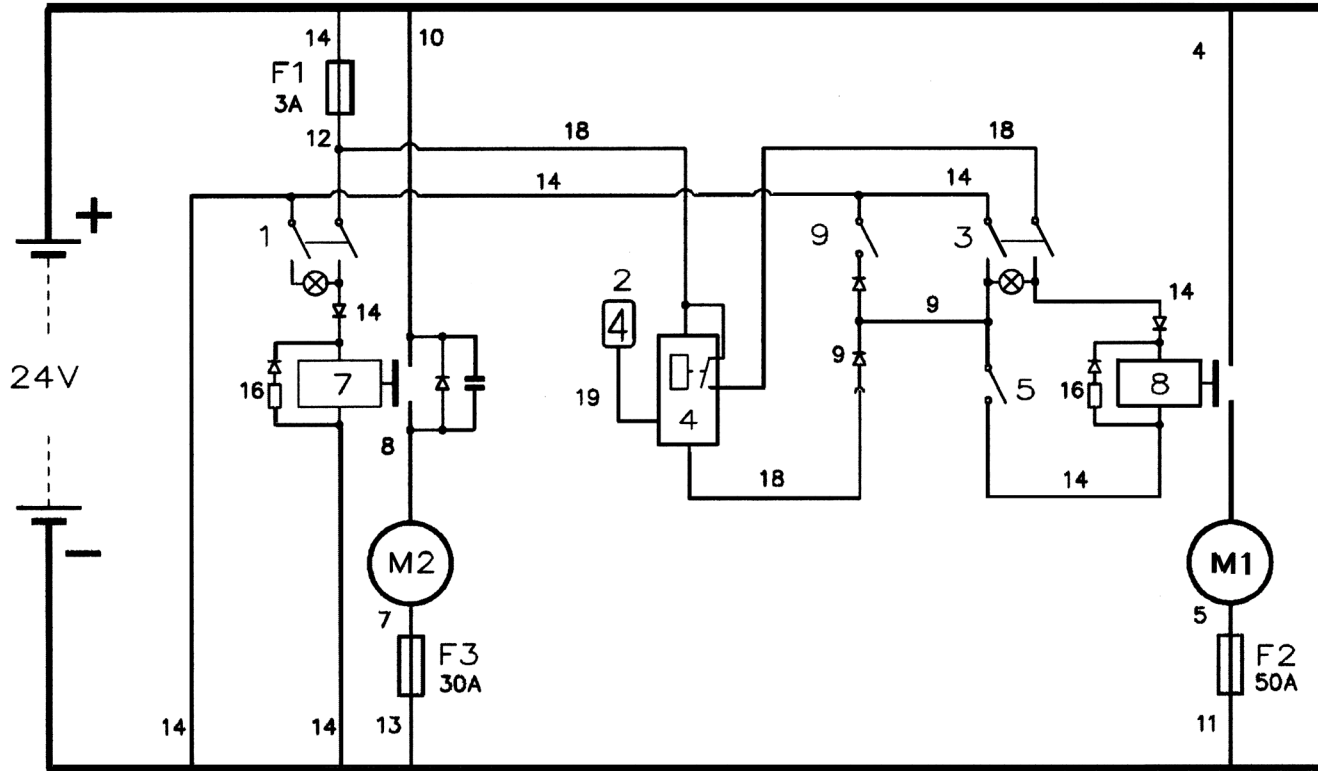

Electrical Parts List - LEAD ACID Batteries

Components

Item	Part Number	Description
1	911172	Bipolar Switch Green 24V Vacuum Motor
2	72300117	Battery Signal Lead/Water Valve
3	911172	Bipolar Switch Green 24V Brush Motor
4	67903001	Battery Check Card
5	72105016	Microswitch Start Brushes
6	72903002	Insulator
7	887550	Relay 24V 30A Vacuum Motor
8	68420110	Remote Control Switch 24V-100A Brush Mtr.
9	72105009	Microswitch Water Valve
10	72700011	Connector Male 50A
11	72700012	Connector Female 50A
12	72700007	Double Connector 30A Vac Motor
13	881347	Lead Acid Batteries, 100 AH/12 Volt - 2 required
M1	68220410	Brush Motor 24V
M2	68130510	Vacuum Motor
F1	72400301	Fuse 30A Faston General Key
F2	72405002	Fuse 50A Faston Brush Motor
F3	72403003	Fuse 30A Faston Vacuum Motor

Cables

Item	Part Number	Description
1-2	68024001	Cable Black-Red + Battery Terminals + 50A Connector
3-4	68024002	Cable Black-Red + 50A Connector
5-6	68024003	Cable Black-Red with Couplings
7-8	68024004	Cable Black-Red with 30A Connector
9	68024005	2 Cables Green
10	68024006	Cable Red with Diode and Condenser
11	68024007	Cable Black
12	68024018	Cable Red
13	68024009	Cable Black
14	68024010	Cable 5x1 + Black Bridges
15	68024011	2 Cables Blue-Brown
16	72500011	Diode and Resistances with Terminal
17	68024013	Cable Black Battery Bridge
18	68024017	3 Cables Black-Red-Green+Connector+Bridge
19	68000892	Cable Display Battery Signal

NOTES

SERVICE LOG

WARRANTY POLICY PACIFIC LIMITED WARRANTY

The **Pacific** ScrubMaster 210 has been manufactured, tested and inspected in accordance with specific engineering requirements. This machine is **WARRANTED** to be free from defects in workmanship and materials for periods as follows from the date of purchase.

Ten (10) Years Parts, One (1) Year Labor – Polyethylene Components	Two (2) Years Parts, One (1) Year Labor – Brush Drive Motors
Five (5) Years Parts, One (1) Year Labor – Main Frame	One (1) Year Parts & Labor – All other components unless excluded below

Travel time for warranty repair is authorized for a period of ninety (90) days following the date of sale to the end user, with a maximum of three (3) hours per claim.

This warranty extends to the original user/purchaser and only when used, operated and maintained in accordance with **Pacific** Operating and Maintenance instructions.

This warranty does not apply to certain wear parts and accessories of the machine such as electrical cords, carbon motor brushes, floor brushes, belts, hoses, tools, squeegee blades, etc., nor does it apply to damage or failure caused by improper use, abuse or neglect. Warranty credit or replacement of return parts including motors, pumps, etc., is subject to incoming inspection of those items.

To secure repair under this warranty, the following procedure should be taken:

1. After the expiration of the ninety (90) day travel time warranty period, the customer is responsible for warranty travel payment or the inoperative machine or warranted parts must be delivered to the authorized dealer with shipping and delivery charges prepaid. If unable to locate the Dealer, you may contact **Pacific** at the address listed herein for the location of the nearest **Pacific** repair center or agent or for other instructions pertaining to your warranty difficulty.
2. Upon compliance with the above warranty procedure, all warranted repairs will be completed at no additional charge or cost to the user.
3. Only **Pacific** or its authorized dealers and agents may make no charge warranty repairs on this product. All others do so at their own risk.

This warranty limits **Pacific** liability to the repair of the product and/or warranted parts replacement and does not include incidental or consequential damages arising from the use of a **Pacific** machine whether defective or not.

BATTERY WARRANTY

In addition to the terms above, any original equipment Pacific Steamex Battery which becomes unserviceable under normal use within a period of ninety (90) days from date of sale to the original user will be repaired or replaced with one of equal specification at our option, F.O.B. any authorized Pacific or Service Branch, with no charge to user, except transportation costs. After the expiration of the above ninety (90) day period, any battery which fails under normal use will be adjusted to the original user with a new battery of equal specification on a twelve (12) month pro rata basis from the date of purchase. Adjustment will be determined using the then current list price, plus transportation costs. Warranty is rendered null and void if battery is not kept filled to the proper level with DISTILLED WATER.

This warranty is in lieu of all other expressed or implied warranties and is extended to the original purchaser/user.

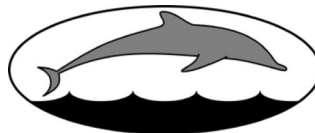

PACIFIC

2259 S. Sheridan

Muskegon, MI 49442-6252

Phone (800) 968-1332 • Fax (800) 863-9536