

POLISHERS

MODELS

SilverRay 133

SilverRay 170

SilverRay 175

SilverRay 200

SilverRay 205

INTRODUCTION

OPERATING & MAINTENANCE INSTRUCTIONS

READ THIS BOOK

This operator's book has important information for the use and safe operation of this machine. Read this book carefully before starting the machine. Keep this book and tell all operators to read the book. If you do not follow the instructions, you can cause an injury or damage equipment, furniture or buildings.

For new books write to:

Pacific
2259 S. Sheridan
Muskegon, MI 49442-6252

Carefully inspect all components to ensure that there is no concealed freight damage. If such damage is discovered, file a "CONCEALED DAMAGE REPORT" immediately with the delivering carrier.

The contents of this manual are based on the latest product information available at the time of publication. Pacific reserves the right to make changes or improvements to its machines without notice.

FOR YOUR CONVENIENCE, RECORD THE FOLLOWING INFORMATION:

MODEL _____

SERIAL NUMBER _____

PART NUMBER _____

DATE PURCHASED _____

IMPORTANT SAFETY INSTRUCTIONS

To assure the safe operation of this machine, you must read and understand all warnings and instructions in this book. If you do not understand, ask your supervisor.

READ ALL INSTRUCTIONS BEFORE USING THIS MACHINE

WARNING: To reduce the risk of fire, electric shock, or injury:

1. You must be trained to operate this machine. This machine is to be operated for its intended use only.
2. Do not operate this machine unless it is completely assembled.
3. Always use a three-wire electrical system connected to the electrical ground. For maximum protection against electrical shock, use a circuit that is protected by a ground fault circuit interrupter. Consult your electrical contractor.
4. To prevent electric shock, always remove the electrical plug from the electrical outlet before doing any repairs or maintenance and when leaving the machine unattended.
5. To prevent electric shock, keep the machine surface dry. Do not subject to rain. Store the machine in a dry building area. Clean the machine with a dry cloth only.
6. Machines can cause an explosion when near flammable materials and vapors. Do not use this machine with or near fuels, grain dust, solvents, thinners, or other flammable materials. Do not use flammables to clean this machine.
7. A qualified or authorized person must do maintenance and repairs.
8. To prevent damage to the power cord, do not move this machine over the power cord. Always lift the power cord over the machine. Do not pull or carry cord, use cord as a handle, close a door on cord, or pull cord around sharp edges or corners. Keep cord away from heated surfaces.
9. Do not use with damaged cord or plug. If the machine is not working as it should, has been dropped, damaged, left outdoors, or dropped into water, return it to a service center.

Grounding Instructions

This machine must be grounded. If it should malfunction or break down, grounding provides a path of least resistance for electric current to reduce the risk of electric shock. This machine is equipped with a cord having an equipment-grounding conductor and grounding plug. The plug must be inserted into an appropriate outlet that is properly installed and grounded in accordance with all local codes and ordinances.

WARNING - Improper connection of the equipment-grounding conductor can result in a risk of electric shock. Check with a qualified electrician or service person if you are in doubt as to whether the outlet is properly grounded. Do not modify the plug provided with the machine - if it will not fit the outlet, have a proper outlet installed by a qualified electrician.

This machine is for use on a nominal 120-volt circuit, and has a grounded plug that looks like the plug illustrated in figure A. A temporary adapter that looks like the adapter illustrated in figures B and C may be used to connect this plug to a 2-pole receptacle as shown in figure B if a properly grounded outlet is not available. The temporary adapter should be used only until a properly grounded outlet (figure A) can be installed by a qualified electrician. The green colored rigid ear, lug, or the like extending from the adapter must be connected to a permanent ground such as a properly grounded outlet box cover. Whenever the adapter is used, it must be held in place by a metal screw.

NOTE: In Canada, the use of a temporary adapter is not permitted by the Canadian Electrical Code

EXTENSION CORDS

Use only three-wire 12/3 or larger gauge approved extension cords that have three-prong grounding type plugs and three-pole receptacles that accept the appliance's plug. Replace or repair any damaged cords or plugs.

When servicing, refer to authorized person only. Use only identical replacement parts.

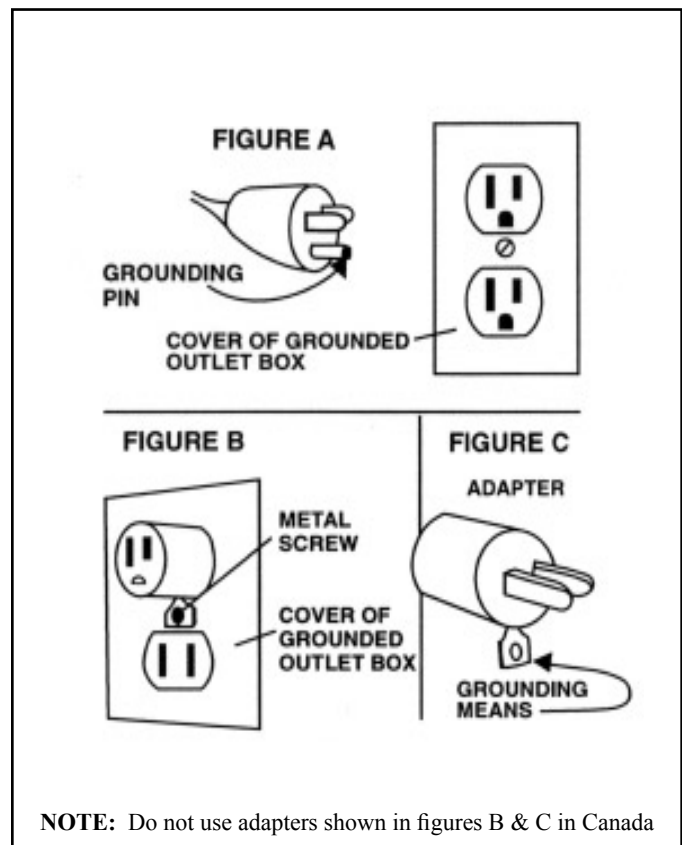

OPERATING PROCEDURES

WARNING! For the safe operation of this machine follow the instructions given in this manual and the training given by your supervisor. Failure to do so can result in personal injury and/or damage to machine and property!

DO NOT OPERATE MACHINE IN AN EXPLOSIVE ENVIRONMENT!

This machine is intended for commercial use.

PREPARATION

To prepare the machine for operation, make sure it is of correct voltage and properly assembled.

Your new floor machine operates in the normal side to side motion of a conventional single disc machine. Be prepared before starting by removing all obstructions or other obstacles in the area to be cleaned. Check the proper application recommendations and procedures found on the label of your cleaning or finish container. **IF IN DOUBT, CALL YOUR SUPERVISOR .**

WARNING! NEVER USE THIS MACHINE WITH FLAMMABLE OR EXPLOSIVE MATERIAL!

For Scrubbing or Polishing: Select the correct floor pad or brush (your supplier can help you). If in doubt, ask your supervisor.

NEVER OPERATE THE MACHINE WITHOUT THE FLOOR PAD OR BRUSH INSTALLED!

To properly attach the brush, **UNPLUG THE FLOOR MACHINE**, place the handle in the vertical position, then tilt the machine back until the handle rests on the floor. Straddle the handle, facing the motor, and grasp the brush with the block toward you. Place the brush or pad clutch plate over the three lugs on the motor drive adapter. Twist the brush right to lock it into position. To remove the brush, **UNPLUG THE MACHINE** and follow the same procedure as above, but by twisting the brush off with a firm jerk to the left. Remove the brush or pad driver when the machine is not in use. This will help prevent brush damage and reduce wobble problems.

OPERATION

Plug the machine's power cable into a properly grounded outlet (see Safety Instructions). Next, adjust the handle height to a comfortable position.

Pull out on the "Watch Dog" Safety Lock button and start the machine by depressing either the left or right switch levers.

Both hands should be placed on the handle when the machine is in operation. The machine will glide sideways over the floor by a slight raising and lowering of the handle. Raise the handle slightly to go to the right. Lower the handle slightly to go left. **Releasing the switch lever stops the machine at once.**

MAINTENANCE

AFTER EACH USE: Store the machine in a clean dry area. Wipe the entire machine and cord down with a clean cloth. Remove the pad or brush and clean thoroughly. Wrap the machine's electrical cord onto the handles and the cord hook provided. **CHECK** the cord and plug for nicks, cuts or damage. Report these to your supervisor for correction.

WARNING! Always disconnect the machine's electrical plug from the electrical outlet before performing any service, maintenance, pad changing or inspection of the machine.

MOTOR: The motor is lubricated for life under normal use. No oiling or greasing is necessary. However, if the machine is used in dusty areas or is used for spray buffing, the motor should be cleaned. Blowing the motor out with compressed air or with the exhaust from a vacuum is suggested. Keeping the motor clean will allow the clear passage of air for ventilation and prevent overheating. If you have any questions regarding the maintenance of your floor machine, **ASK YOUR SUPERVISOR.**

SILVERRAY MODELS

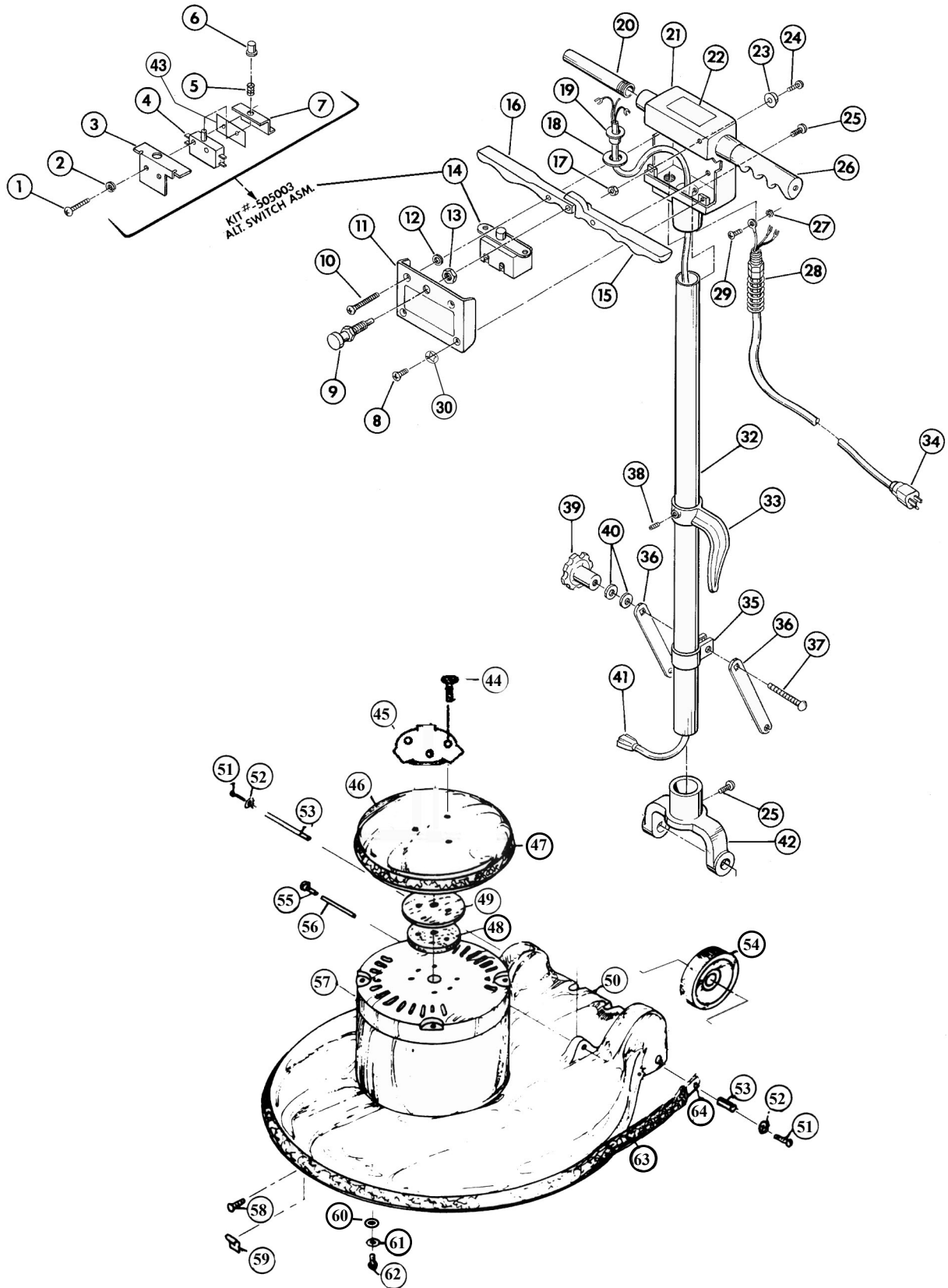

SILVERRAY Parts List

ITEM	PART NO.	DESCRIPTION	QTY.
1	W323D	Screw, 6-32x1 Pan Hd.	2
2	980016	Washer, #6 Ext. Tooth	2
3	500801	Bracket, Switch Mounting	1
4	911135	Switch	1
5	508301	Spring	1
6	507001	Plunger	1
7	500802	Bracket, Switch	1
8	962002	Screw, 10-32 x 1/2 Oval Hd.	2
9	504810	Interlock Asm.-Switch	1
10	962011	Screw, 10-32 x 3/4 Oval Hd.	2
11	506430	Switch Cover Plate	1
12	509821	Washer, Rubber	2
13	920005	Nut, 3/8-24 Hex	1
14	505003	Switch Assembly	1
15	505121	Lever, Switch Left	1
16	505120	Lever, Switch Right	1
17	920001	Nut, 10-32 Elastic Stop	1
18	509830	Washer, Handle Tube	1
19	503320	Flange, Strain Relief	1
20	505720	Handle Nipple	2
21	501325	Switch Box, Polished	1
22	515150	Warning Label	1
23	501210	Bumper, Handle	1
24	962003	Screw, 10-32 x 3/4 Pan Hd.	1
25	962006	Screw, 1/4-20 x 1/2 Pan Hd.	4
26	503711	Handle Grip, Grey	2
	501501	Cap, Protective End (Blue)	2
27	980015	Washer, #10 Shakeproof	1
28	508520	Strain Relief-Complete	1
	502020	Strain Relief-Brass Clamp	1
29	962015	Screw, 10-32 x 3/8 Pan Hd.	1
30	980018	Washer, #10 Countersunk	1
32	509082	Handle Tube	1
33	504420	Cord Hook	1
34	502421	Cord Asm.-50 ft. Grey	1
35	502021	Clamp-Handle	1
36	500880	Brace, Handle Support-13"	2
	500840	Brace,Handle Sup.-17"&20"	2
37	962009	Bolt, Carriage 5/16-18 x 2-1/2	1
38	962005	Screw, 1/4-20 x 3/8 Allen	1
39	505010	Turn Knob	1
40	980007	Washer, 5/16 Flat	2

ITEM	PART NO.	DESCRIPTION	QTY.
41	908004	Handle Cord	1
42	509920	Yoke, Handle	1
43	504702	Insulator-Switch	1
44	962004	Screw, 10-32 x 1-1/4 oval	3
45	501520	Tote-A Brush Cap	1
46	502310	Drip Cover, Motor - 13"	1
	502380	Drip Cover, Motor-17"&20"	1
47	501212	Motor Bumper-13"	1
	501287	Motor Bumper-17"&20"	1
48	508210	Spacer, Drip Cover-13"	1
	508220	Spacer, Drip Cover-17"&20"	1
	962019	Screws for Spacer	3
49	509823	Washer, Felt	1
50	501810	Base Frame, Polished - 13"	1
	501841	Base Frame, Polished - 17"	1
	501851	Base Frame, Polished - 20"	1
51	962006	Screw, Yoke	2
	980002	Lock Washers - 13" Only	2
52	509820	Washer, Fibre - 17"&20"	4
	980005	Washer, Wave - 13"/17"&20"	2/4
53	507710	Axle, Wheel-13"	1
	507740	Axle, Wheel-17"&20"	1
54	509710	Wheel, 3" - 13"	1
	509780	Wheel, 4" - 17"	2
	509781	Wheel, 5" - 20"	1
55	962006	Screw, Yoke Rod	2
56	487701	Rod, Yoke - 13"	1
	508213	Spacers - 13" Only	4
	507480	Rod, Yoke-17"&20"	1
57	See Page 6	Motor Assembly	1
58	962001	Screw, Clips - 13"/17"&20"	1/3
59	502110	Clips, Bumper - 13"/17"&20"	1/3
60	980002	Washer, 1/4 Lock	4
61	980004	Washer, 1/4 Flat-17"&20"	4
62	962007	Screw, Motor - 13"	4
	962010	Screw, Motor - 17"&20"	4
63	501220	Bumper, Base - 13"	1
	501242	Bumper, Base - 17"	1
	501260	Bumper, Base - 20"	1
64	508011	Bumper Strap - 13"	1
	508041	Bumper Strap - 17"	1
	508051	Bumper Strap - 20"	1

MOTOR PARTS LIST for SILVERRAY MOTORS

ITEM	DESCRIPTION	PART NUMBERS			
		505210	505299	505274	505251
		1/3 HP Motor-115V, 60CY Howell #37PD4-3134-1	1 HP Motor-115V, 60CY Baldor #36J378Y799	1.5 HP Motor-115V, 60CY Baldor #36J378T115	1.5 HP Motor-115V, 60CY Motor & Gear Assembly
		503501 Gear Asm. for 1/3 HP 11:1 - 1 Planet	503522 Gear Asm. for 1 HP 10:1 - 2 Planet	503523 Gear Asm. for 1.5 HP 10:1 - 3 Planet	503523 Gear Asm. for 1.5 HP 10:1 - 3 Planet
A	Ring Gear Housing	504202	504209	504209	504209
B	Bearing, Ring Gear Housing	902007	902007	902007	902007
C	Planet Gear Hsing	504204	504216	504208	504208
D	Bearing, Pinion Lower	902006	902005	902005	902005
E	Screw-Ring Gear Hs.	960016 (Qty.6)			
F	Screw, Planet Gear Housing	960017 (Qty.6)			
G	Motor Cord	908021	908090	908090	
H	Run Capacitor	NA	911235	911236	911305
I	Cover,Run Capacitor	NA	502374	502374	502320
J	Cover, Start Capacitor	502312	502374	502374	502320
K	Start Capacitor	911042	911239	911239	911304
L	Bolt	960013	960035	960035	
M	End Bell	502913	502931	502931	502931
N	Stator Asm, 115V-60C	503106	503125	503131	503134 (No Capacitors)
O	Bearing, Motor Top	902003	902003	902003	902003
P	Stationary Switch	911043	911251	911251	911306
Q	Rotary Switch	911044	911219	911289	911307
R	Rotor Assembly	500406	500429	500435	500438 (No Bearings or Switch)
S	End Bell-Motor Lower	502916	502927	502927	502927
T	Cover, Ring Gear	502314	502317	502317	502317
U	Bearing, Upper Gear Housing	504207	902015	902015	902015
V	Bearing, Pinion Upper	902005	902005	902005	902005
X	Coupling Flexible	502460	502460	502460	502460
Y	Spacer	508222	508211	508211	508211
Z	Pinion	503507	503510	503510	503510
AA	Shaft-Planet Gear	507724	507701 (Qty.2)	507701 (Qty.3)	507701 (Qty.3)
BB	Bearing-Planet Shaft	902008 (Qty.2)	902016 (Qty.4)	902016 (Qty.6)	902016 (Qty.6)
CC	Gear-Planet	503509	503511 (Qty.2)	503511 (Qty.3)	503511 (Qty.3)

AC MOTOR ILLUSTRATION

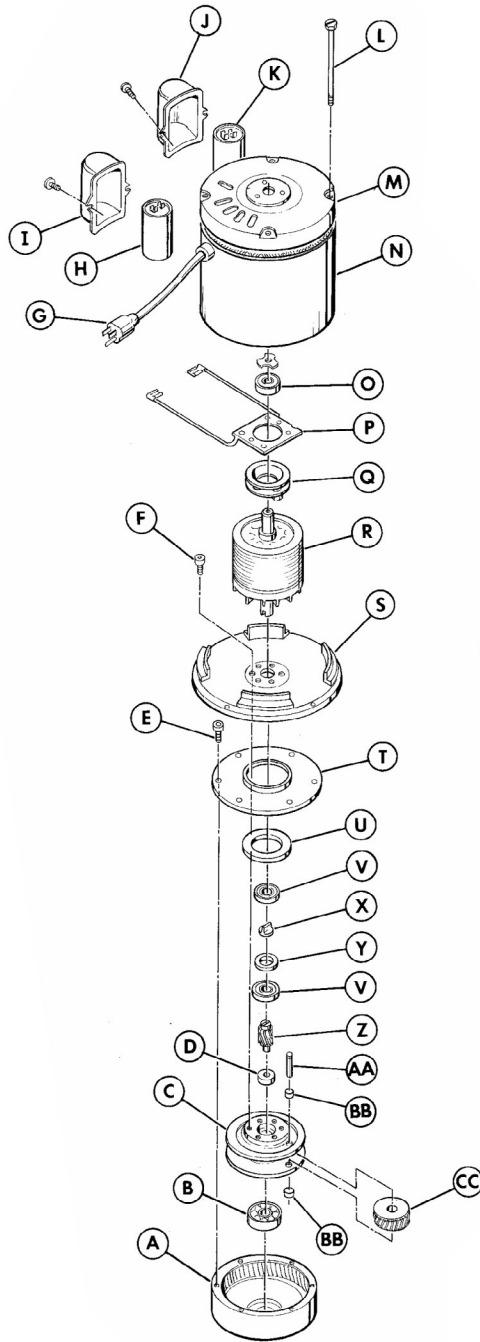

WIRING DIAGRAM

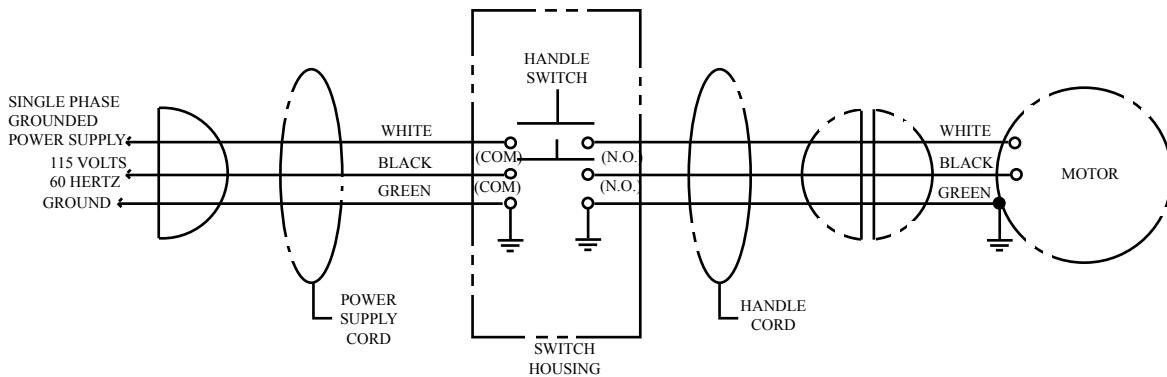

WARRANTY POLICY SILVERRAY POLISHER MODELS

The **Pacific** Polisher has been manufactured, tested and inspected in accordance with specific engineering requirements and is WARRANTED to be free from defects in workmanship and materials as follows:

Five (5) years parts, One (1) year labor - AC Motor and Gear Unit, except motor switches, capacitors and flex couplings which have a one (1) year warranty.

Five (5) years parts, One (1) year labor - Castings

One (1) year parts and labor - All other components unless excluded below.

This warranty extends to the original user/purchaser and only when used, operated and maintained in accordance with **Pacific** Operating and Maintenance instructions.

This warranty does not apply to the following wear parts and accessories of the machine including:

<u>Description</u>	<u>13" Model</u>	<u>17" Model</u>	<u>20" Model</u>
Cord Assembly	502422	502422	502422
Wheel	509710	509780	509781
Handle Grip, Grey	503711	503711	503711
Bumper, Base	501220	501242	501260
Bumper, Drip Cover	501202	501287	501287

Nor does it apply to damage or failure caused by improper use, abuse or neglect. Warranty credit or replacement of return parts including motors, etc., is subject to incoming inspection of those items.

To secure repair under this warranty, the following procedure should be taken:

- The inoperative machine or warranted parts must be delivered to the authorized dealer with shipping and delivery charges prepaid. If unable to locate the Dealer, you may contact **Pacific** at the address listed herein for the location of the nearest **Pacific** repair center or agent or for other instructions pertaining to your warranty difficulty.
- Upon compliance with the above warranty procedure, all warranted repairs would be completed at no additional charge or cost to the user.
- Only **Pacific** or its authorized dealers and agents may make no charge warranty repairs on this product. All others do so at their own risk.

This warranty limits **Pacific** liability to the repair of the product and/or warranted parts replacement and does not include incidental or consequential damages arising from the use of a **Pacific** machine whether defective or not.

This warranty is in lieu of all other expressed or implied warranties and is extended to the original purchaser/user.

PACIFIC

2259 Sheridan

Muskegon, Michigan 49442

Ph: (800) 968-1332 Fax: (231) 773-1642

www.nextwaveofclean.com