

# REPAIR MANUAL

## DYNAMO & TRIUMPH 440

---

This Repair Manual is a supplement to the Operating & Maintenance Instructions. Refer to the Operating & Maintenance Instructions for the preparation, operation and standard maintenance instructions. If you do not follow the instructions, you can cause an injury or damage equipment, furniture or buildings.

Maintenance and repairs must be done by authorized personnel only. To prevent injury, always unplug the machine before doing any repairs.

For new books write to:

*Pacific Steamex, Inc.*  
2259 S. Sheridan  
Muskegon, MI 49442-6252

The contents of this manual are based on the latest product information available at the time of publication. Pacific Steamex reserves the right to make changes or improvements to its machines without notice.

**FOR YOUR CONVENIENCE, RECORD THE FOLLOWING INFORMATION:**

**MODEL** \_\_\_\_\_

**SERIAL NUMBER** \_\_\_\_\_

**PART NUMBER** \_\_\_\_\_

**DATE PURCHASED** \_\_\_\_\_

## BELT REPLACEMENT

**Note: Throughout this manual there are references to Drawing 1 and Drawing 2. See Page 8 for Drawing 1 and Page 10 for Drawing 2.**

1. Empty both the solution and recovery tanks.
2. To access the belt, the machine will either need to be placed upside down or laid on its' side. If you prefer to lay the machine upside-down, first remove the handle (Drawing 1, Item 4) from the recovery tank to avoid bending it. You will need to take out two sets of hardware (Drawing 1, Items 1,2,3 & 80).
3. Lower the operator's handle (Drawing 1, Item 16) down out of the way.
4. Place the machine either upside-down or on its' side.
5. Remove the four sets of screws and washers that attach the brush housing assembly to the body of the machine. Note that the brush housing assembly is still attached to the body with hoses.

**NOTE: DO NOT OVERTIGHTEN WHEN REASSEMBLING.**

Reference Drawing 1, Page 8

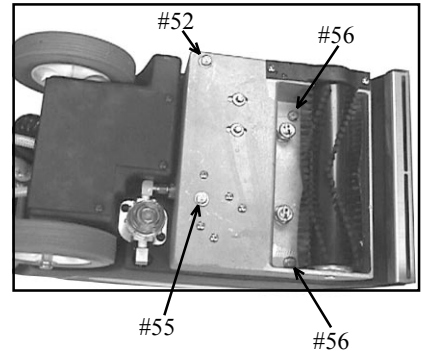

6. Loosen the two sets of brush motor bracket mounting bolts and washers. Reference Drawing 2, Items 18, 19 & 20.

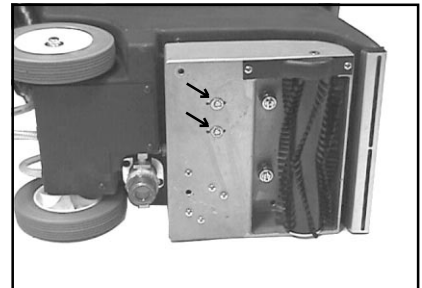

7. Take off the brush guard by removing these two screws, Reference Drawing 2, Item 28.

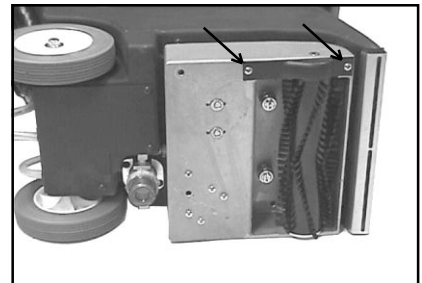

Note: If adjusting the belt tension, slide the motor away from the brush to tighten the belt or toward the brush to loosen. Keep the motor perpendicular to the belt.

## BELT REPLACEMENT

---

**8.** Now take out the two axle shaft retaining screws located on either side of the brush housing to release the brush assembly.

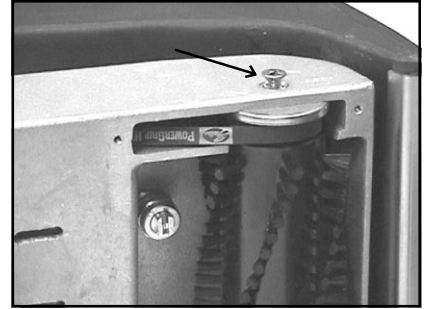

**9.** Remove the old belt, loop the new belt over the brush cog and drive pulley. Reassemble, being careful not to pinch or kink any hoses.

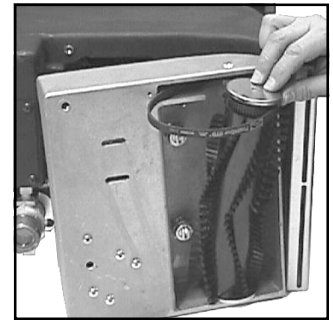

## BRUSH MOTOR REPLACEMENT

---

1. Follow steps 1-6 in the “Belt Replacement” section, however remove the brush motor bracket bolts in step 6 on page 2. Then proceed as follows.

2. Disconnect the white and black leads.

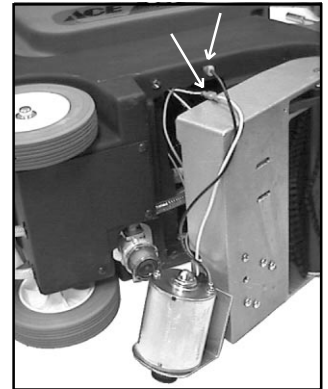

3. Remove the ground wire from the ground post in the brush housing. Reference Drawing 2, Item 21.

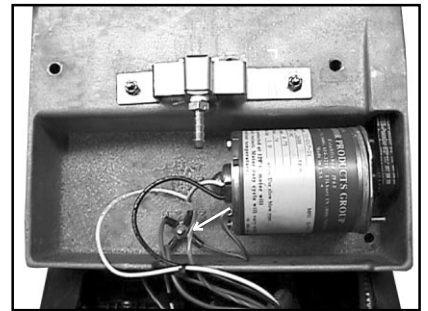

4. Remove the nut and washer that hold the brush motor to its' bracket. Reference Drawing 2, Items 5 & 6.

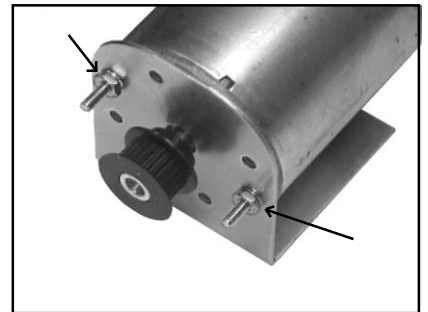

5. Replace the brush motor. Make sure all the hardware is tightened and the wiring is reconnected. Reassemble the machine, being certain not to pinch or kink any hoses.

## PUMP REPLACEMENT

1. Remove the brush housing assembly. Refer to “Belt Replacement”, steps 1-5.

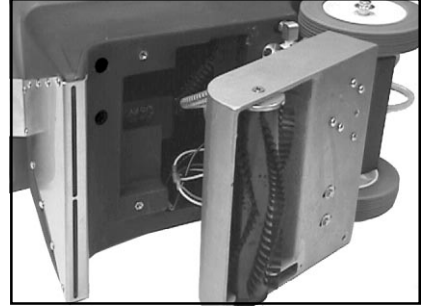

2. Disconnect the black and white leads from the pump.

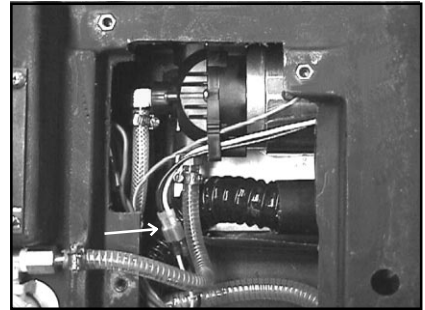

3. Now remove the hoses from the pump. Loosen each hose clamp. Slightly heat the hoses up, then twist and pull the hoses off the elbows. Remove the pump.

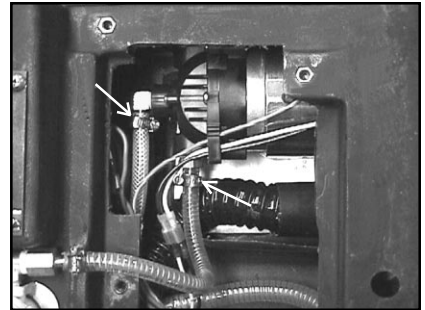

4. Lift off the recovery tank, the pump cover plate is accessible (Drawing 1, Item 62). Remove the four screws (Drawing 1, Item 106) that connect the pump assembly to the cover plate.

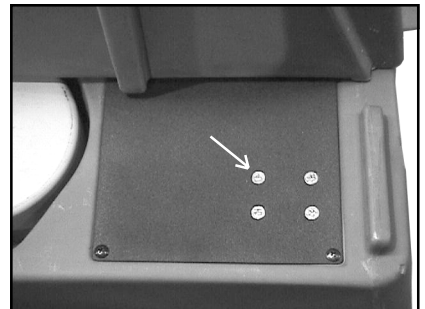

5. Remove the pump assembly from the bottom of the machine. Install the new pump and follow the previous steps in reverse order. Make sure all wire connections are properly plugged in and the hose connections are secure. Make sure the hoses aren't pinched or kinked when the housing is reassembled to the machine.

## VACUUM MOTOR REPLACEMENT

1. Remove the brush housing assembly. Refer to “Belt Replacement”, steps 1-5.

2. Remove the rear cover, reference Drawing 1, Item 37.  
Follow these steps:

- a) Disconnect the quick connects on the hose (Drawing 1, Items 34 & 35).
- b) Take off the hose clamp.
- c) Remove the hose strap (Drawing 1, Item 31).

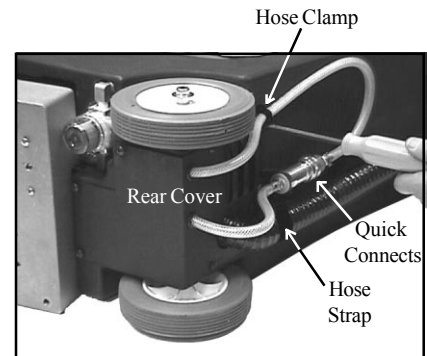

- d) Now remove the screws that hold the rear cover to the body.
- e) Spray the two grommets (Drawing 1, Item 36) with glass cleaner (this will keep the grommets in place).
- f) Slide the cover away from the machine.

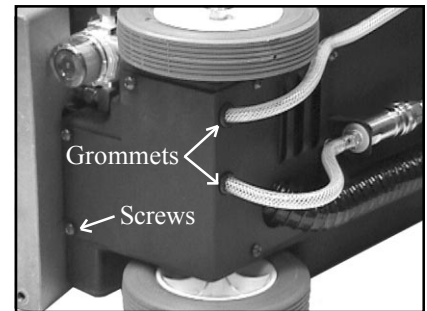

3. The wiring can now be seen. Disconnect the two black leads on the vacuum motor from the black and white leads. Tape the black and white leads off to the side for easier reconnecting later.

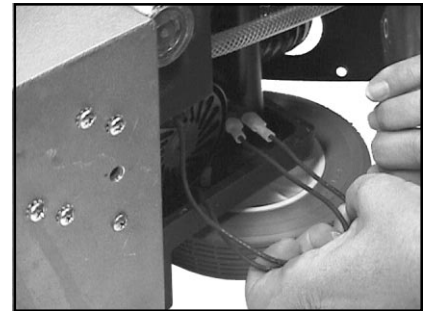

4. Remove the two sets of hardware (Drawing 1, Items 56, 54 & 59) that connect the solution tank to the body.

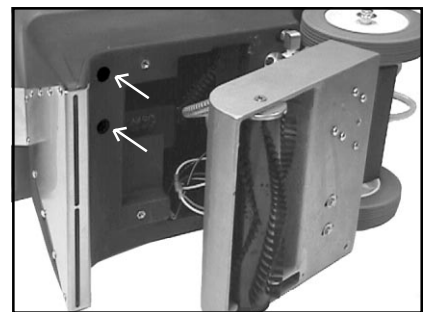

## VACUUM MOTOR REPLACEMENT

5. Return the machine to the upright position and lift off the recovery tank.

6. Take out the two screws that attach the control panel (Drawing 1, Item 10) to the solution tank.

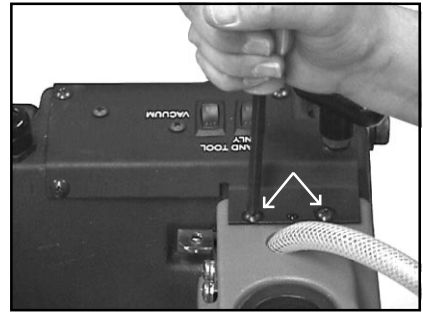

7. Remove the screw that holds the solution tank bracket (Drawing 1, Item 70) to the body of the machine.

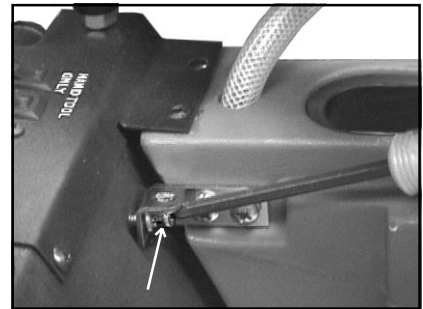

8. The solution tank can now be rotated sideways to access the vacuum motor.

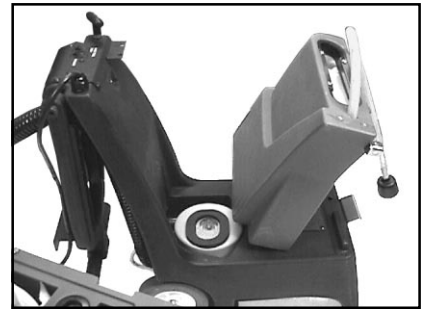

9. Remove the three vacuum motor mounting sets (Drawing 1, Items 68 & 53). The vacuum motor can now be lifted off its studs. If it is difficult to remove, the vacuum hose may need to be repositioned. From underneath the machine, slide the hose to the far left, inside the base (from the operators position).

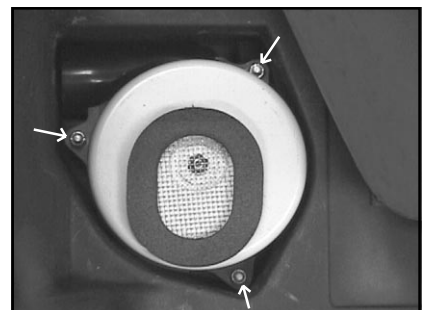

10. Install the new vacuum motor and gaskets, ensuring not to pinch wires between the motor and machine body. Follow the above steps in reverse order. Make sure all wiring connections are secure and hardware is tightened.

# DRAWING 1 - Machine

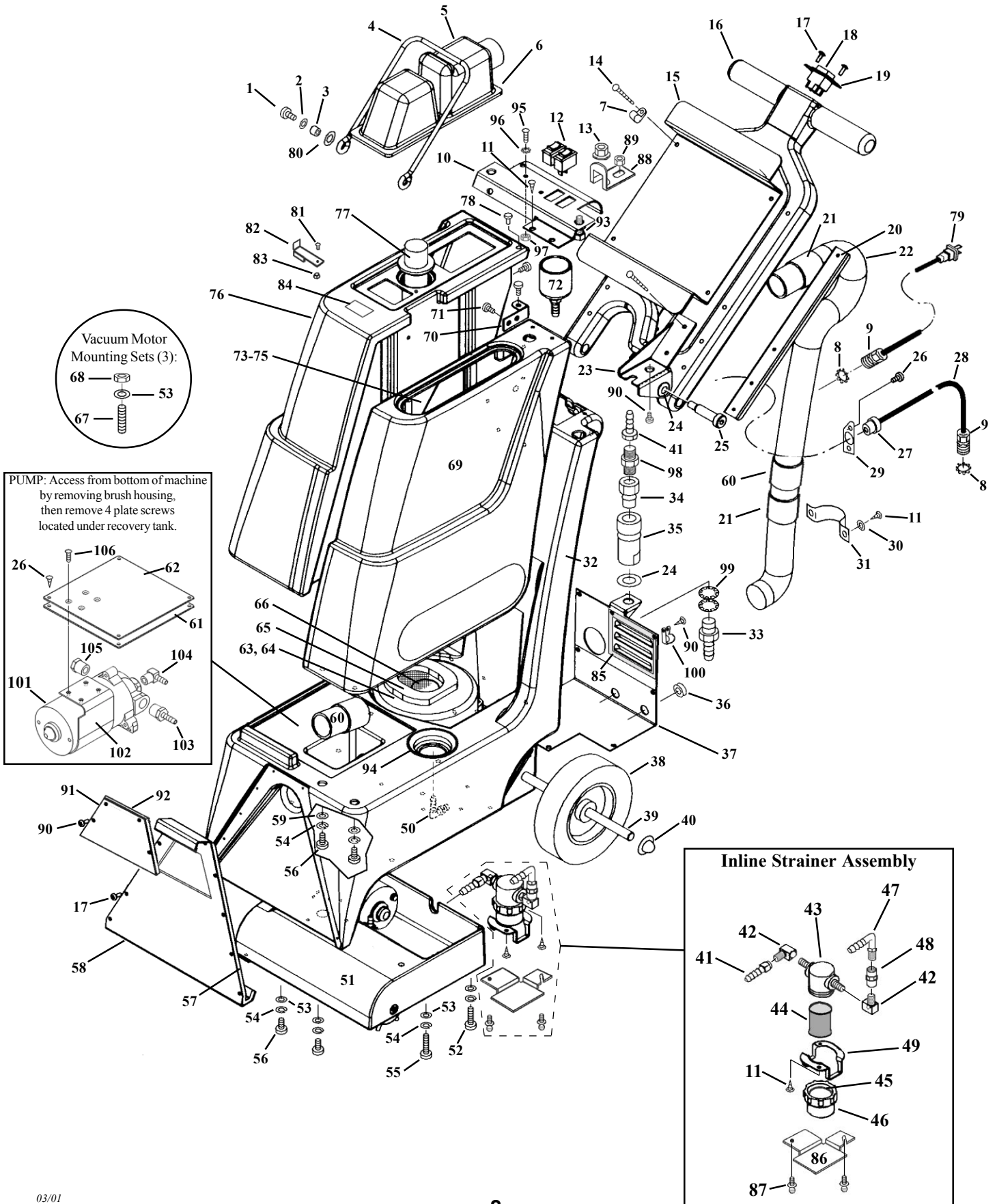



# DRAWING 1 - Machine Parts List

ITEM	PART NO.	DESCRIPTION	QTY.
1	962007	Screw	2
2	980004	Washer, 1/4 Flat	2
3	248201	Spacer, Tank Handle	2
4	243902	Handle, Recovery Tank	1
5	242701	Dome	1
6	243402	Gasket, Dome	1
7	612001	Clamp, Cable	2
8	920619	Nut, 1/2 Pipe Lock	1
9	248502	Strain Relief, Straight	2
10	246605	Plate, Control	1
11	W351D	Screw, 10-24 x 1/2 THP	11
12	911089	Switch, Rocker	2
13	920030	Flange Nut	1
14	962147	Screw, 10-32 x 1.75 PHP	8
15	240806	Bracket, Cord Wrap	1
16	243901	Handle, Black	1
17	W136D	Screw, #8 x 1/2 THP	10
18	3704	Switch, Momentary	1
19	206651	Plate, Switch	1
20	248505	Stiffener, Handle	2
21	242402	Cuff, Hose (to dome)	2
	962119	Screw, Hose to Dome	1
22	244108	Hose, 1.25x4'	1
23	247003	Pivot, Handle LH	1
	247004	Pivot, Handle RH	1
24	980612	Washer, Thrust	4
25	960033	Screw, 1/2x1-1/2 Shoulder	2
26	W136D1	Screw, #8 x 1/2 THP	2
27	508519	Strain Relief	1
28	908083	Cord Asm, Handle	1
29	246602	Plate, Strain Relief	1
30	W107D	Washer	4
31	248504	Strap, Hose	2
32	241307	Body (used with pump 247006)	1
33	S223P	Brass Barb, 1/4 to 1/4 MPT	1
34	203302	Quick Connect, 1/4 Male	1
35	203308	Quick Connect, 1/4 Female	1
36	243801	Grommet	2
37	242302	Cover, Rear	1
38	209771	Wheel, 6 x 1-1/2 Grey	2
39	240501	Axle, Wheel	1
40	S482P	Snap Axle Cap	2
41	243304	Fitting	2
42	242901	Elbow	2
43	241305	Body, Inline Strainer	1
44	248506	Strainer Screen, Inline	1
45	243405	Gasket, Inline Strainer	1
46	241501	Clear Cap, Inline Strainer	1
47	3771	Elbow	1
48	S613A	Coupling	1
49	240801	Bracket, Strainer	1
50	3771	Elbow, Under Sol'n Tank	1
51	244202	Housing, Brush	1
52	962152	Bolt, Tap 1/4-20 x 3-1/4	1
53	W104D	Washer, 1/4 Flat	7

ITEM	PART NO.	DESCRIPTION	QTY.
54	980002	Washer, 1/4 Lock	9
55	962151	Screw, 1/4-20 x 4 HHCS SS	1
56	W189D	Screw, 1/4-20 x 3/4 HH SS	4
57	243403	Gasket, Vac Shoe	1
58	246606	Plate, Vac Shoe	1
59	W311D	Washer	4
60	242401	Cuff, Hose	2
61	243408	Gasket, Pump Plate	1
62	247005	Plate, Cover	1
63	245203	Vac Motor	1
64	603473	Gasket, Under Vac Mtr.	1
65	243401	Gasket, Vac Transfer	1
66	248503	Screen, Vac Intake	1
67	248401	Stud, Threaded	3
68	920011	Nut, 1/4-20 Elastic Stop	3
69	248604	Solution Tank, Grey	1
70	240803	Bracket, Solution Tank	1
71	962006	Screw, 1/4-20x1/2 PHP	3
72	240202	Adaptor, Hose to Dome	1
	203359	Fitting, Hose Barb 3/8	2
73	243301	Filter Asm, Solution	1
74	200871	Brackets, Filter	2
75	W136D	Screw, #8 x 1/2 THP	4
76	248603	Recovery Tank, Grey	1
77	243307	Filter Asm., Standpipe	1
78	246701	Pin, Tank Locator	1
	920019	Nut, 1/4-20 Hex Jam	1
79	908059	Cord Asm.	1
80	980005	Washer, Wave	2
81	962154	Screw, 6-32x5/8 PHP	1
82	247201	Retainer, Filter	1
83	W144D	Nut, 6-32 Hex w/Nyloc	1
84	245109	Label, Warning	1
85	243406	Gasket, Exhaust	1
86	243602	Guard, Strainer	1
87	962153	Screw, 10-24x1/2 Wsher. Hd.	2
88	245113	Lock, Handle	2
89	920017	Nut	2
90	W350D	Screw 10-24x1/2 THP MS SS	10
91	242702	Door, Clean-Out	1
92	243407	Gasket	1
93	962022	Bolt	2
94	223470	Gasket	1
95	W343D	Screw, 10-24x1 PHP	2
96	980015	Washer #10 Ext. Tooth	2
97	W106D	Nut, 10-24 Hex S/S	2
98	249401	Valve, Check Inline	1
99	980035	Washer, Int. Tooth	2
100	242002	Clamp	1
101	247006	Pump, 60 psi	1
102	240810	Bracket, Pump Mounting	1
103	S535P	Brass Barb 1/4 to 3/8 MPT	1
104	242902	Elbow, 1/4 MPTx1/4 Barb 90	1
105	S804N	Plug, 3/8 Brass HH	1
106	962001	Screw, 10-24x1/4 FHP	4

Not Shown:	Hoses:	
244110	Hose, Strainer to Pump	0.75 ft.
244104	Hose, Pump to QC	1.92 ft.
244105	Hose, Tee to QC	2.75 ft.
244102	Hose, Tank to Strainer	1.17 ft.
244107	Hose, Adaptor Fill	5.5 ft.

Not Shown:	Labels:	
205171	Label, Push to Clean	1
245111	Label, Instructions	1
245112	Label, Defoamer	1

# Brush Housing Assembly

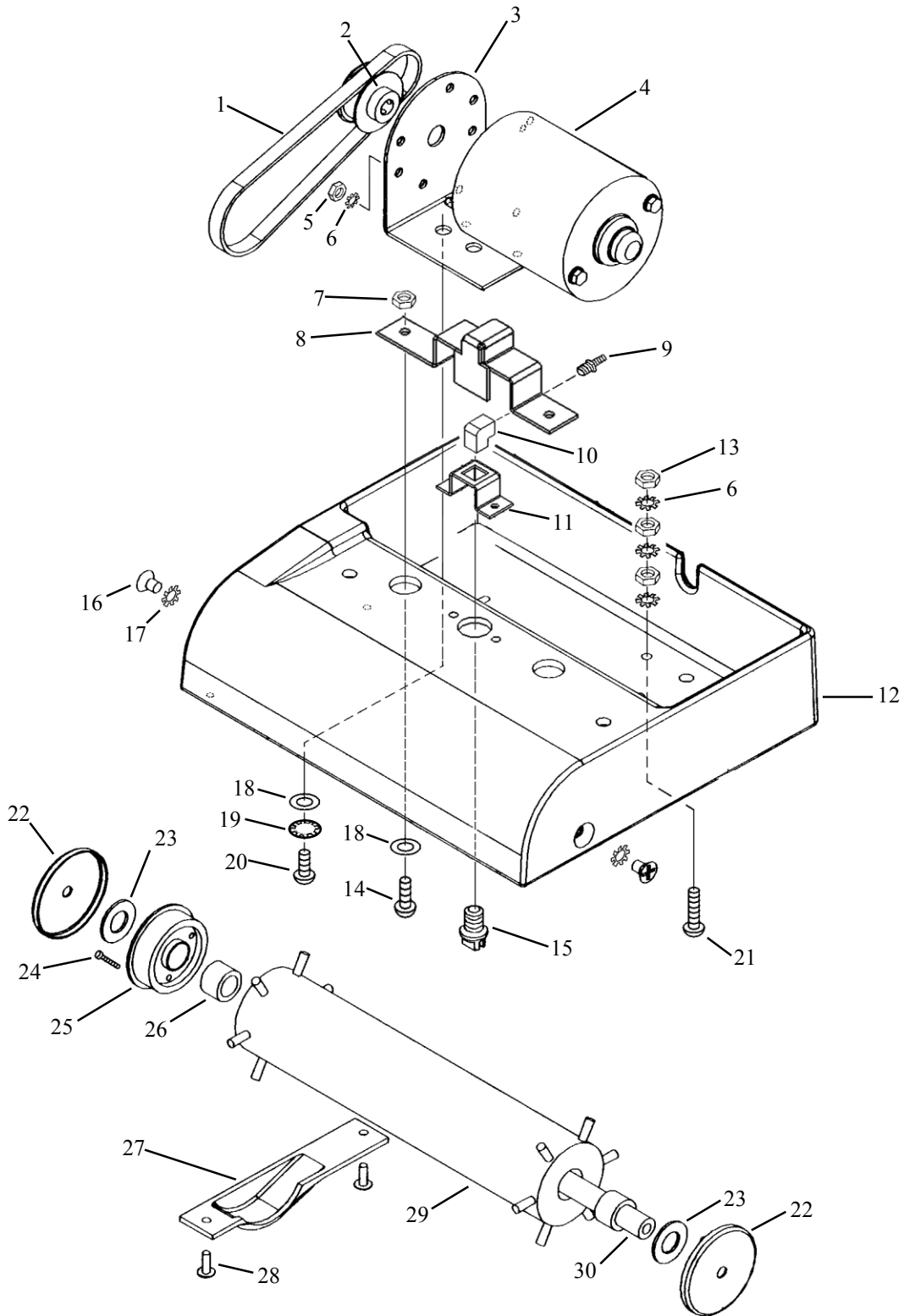

## Brush Housing Assembly Parts List

ITEM	PART NUMBER	DESCRIPTION	QTY.
1	903009	Belt	1
2	246901	Pulley, Drive	1
3	240804	Bracket, Motor Mting	1
4	245202	Motor, Brush Drive	1
5	W329D	Nut, 10-32 Hex	2
6	980015	Washer, #10 Ext. Tooth	5
7	920017	Nut, 10-24 ESNA S/S	4
8	240812	Bracket, Top Single Jet	1
9	S296P	Brass Barb 1/4 to 1/8 MPT	1
10	243306	Fitting-Elbow 1/8	1
11	240811	Bracket, Bottom Single Jet	1
12	244202	Housing, Brush	1
13	W106D	Nut, 10-24 HEX S/S	3
14	W153D2	Screw, 10-24x3/4 PHP	4
15	244902	Jet-Spray 11004	1
16	W353D	Screw, 1/4-20x1/2 FHP	2
17	980032	Washer, 1/4 Flat Ext.	2
18	980075	Washer, 3/16 Fender	4
19	W124D	Washer-Lock,#10 Int.Tooth	2
20	962150	Screw, 10-24x1/2 HH SS	2
21	962113	Grounding Screw	1
22	213601	Guard, Brush	2
23	980612	Washer, Thrust	2
24	962062	Screw, Pan Hd.	3
25	3743	Cog, Brush	1
26	3677	Bearing, Rulon Sleeve	2
27	243601	Guard, Belt	1
28	W199D1	Screw, 8-32 x 1/2 THP	2
29	3731	Brush	1
30	217701	Shaft, Brush	1

## WIRING DIAGRAM

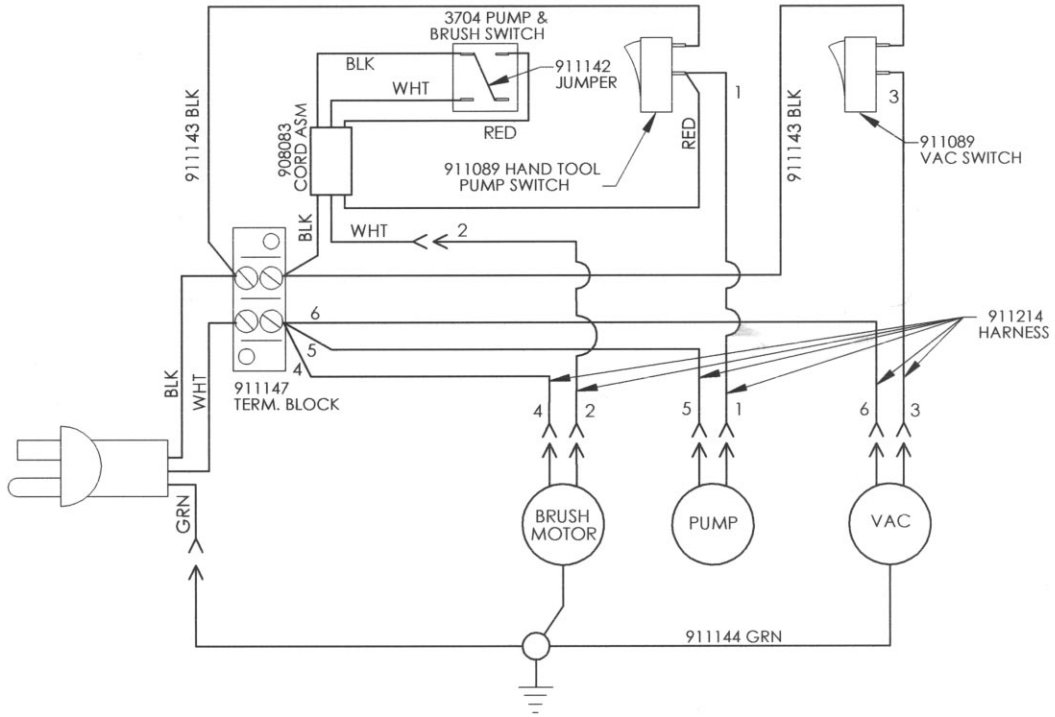

## WIRING DIAGRAM MACHINE WITH OPTIONAL HOUR METER

