



PACIFIC



The contents of this manual are based on the latest product information available at the time of publication. Pacific reserves the right to make changes or improvements to its machines without notice.

Carefully inspect all components to ensure that there is no concealed freight damage. If such damage is discovered, file a "CONCEALED DAMAGE REPORT" immediately with the delivering carrier.

FOR YOUR CONVENIENCE, RECORD THE FOLLOWING IMPORTANT INFORMATION:

For new manuals write to:

Pacific
2259 S. Sheridan
Muskegon, MI 49442-6252

SERIAL NUMBER

DATE PURCHASED

or download the most recent version of the manuals from our website:

www.pacificfloorcare.com



PACIFIC







SAFETY INSTRUCTIONS

- 1) You must have training in the operation of the machine before using it. **READ THE INSTRUCTION BOOK.** If you do not understand any instruction, ask your supervisor.
- 2) Make sure all labels, decals, warnings, cautions and instructions are fastened to the machine.
- 3) Read the labels carefully on the machine. Do not cover them for any reason and replace them if damaged.
- 4) Do not operate this machine unless it is completely assembled and inspect the machine carefully before operation.
- 5) Pay close attention to other people and especially children while operating this machine.
- 6) Be a careful driver and do not strike shelving or scaffolding, especially where there is a danger of falling objects.
- 7) Machines can cause an explosion when operated near flammable materials and vapors. Do not use this machine with or near fuels, grain dust, solvents, thinners, or other flammable materials.
- 8) In case of fire, use a powder extinguisher. Do not use water.
- 9) Do not use this machine as a means of transport.
- 10) Do not use acid solutions that could damage the machine or flooring.
- 11) Adjust your speed to the conditions of the floor.
- 12) Do not turn the machine on an incline. Do not stop and leave the machine on a ramp or incline.
- 13) During any maintenance operation disconnect the power supply from the machine.
- 14) Lead acid batteries generate gases that can cause an explosion. Read the instruction manual supplied with the battery charger. Keep sparks and flames away from batteries. **NO SMOKING.** Charge the batteries only in an area with good ventilation.
- 15) Do not use a charger if the power cord is damaged or a charger that is not matched to the machine.
- 16) Always wear eye protection and protective clothing when working near batteries. Remove all jewelry. Do not put tools or other metal across the battery terminals, or on the top of the batteries.
- 17) Maintenance and repairs must be performed by authorized Service Centers only.
- 18) Keep the electrical parts of the machine dry. Do not wash the machine with direct water jets or high pressure, or with corrosive material. For storage, keep the machine in a dry location.
- 19) Water solutions or cleaning materials used with this type of machine can leave wet areas on the floor surface. These areas can cause a dangerous condition for the operator or other persons. Always put **CAUTION** signs near the area you are cleaning.
- 20) Do not reach under shrouds with fingers, hands, or toes when machine is running.



PACIFIC

SYMBOLS USED ON THE AUTOMATIC SCRUBBER

	Water Valve Indicator
	Brush Drive Motor Control Switch
	Vacuum Motor Control Switch
	Squeegee Lift Lever Indicator
	Battery Charge Indicator
	Water Flow Control Indicator



PACIFIC

MACHINE PREPARATION

1) UNPACKING THE MACHINE

- a) Take off the outer packaging.
- b) The machine is fastened to the pallet with wooden wedges that block the wheels. Remove tie down straps.
- c) Using a ramp, pull the machine off the pallet.

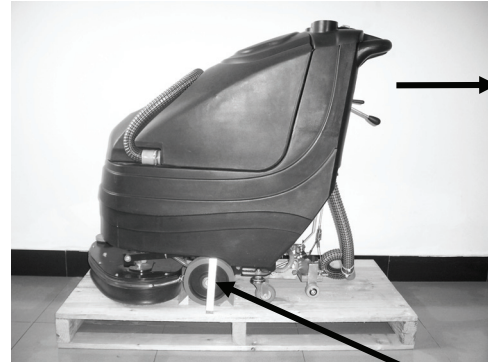

Pull
Backwards

Remove

2) BATTERY INSTALLATION

- a) Remove the squeegee hose from the recovery tank.
- b) Remove the vacuum cover by rotating it counterclockwise.
- c) Remove recovery tank by lifting tank by lift chain at the back of the tank and the drain hose at the front of the tank.

Remove

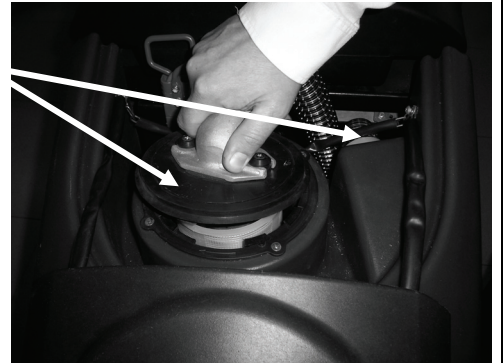

Lift Chain

Drain Hose Lift Point





PACIFIC

MACHINE PREPARATION

BATTERY INSTALLATION (Cont.)

- d) Place the batteries in the battery compartment.
- e) Connect the battery connector to the machine connector
- f) Replace the recovery tank and reassemble the vacuum cover and squeegee hose.

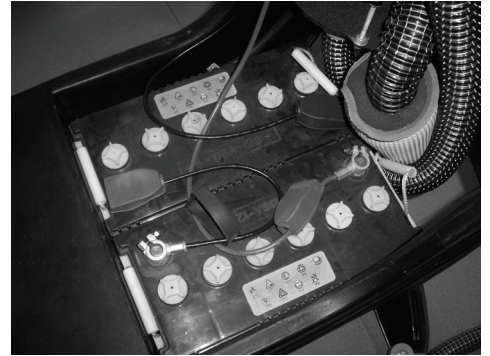

Machine Connector

Battery Connector

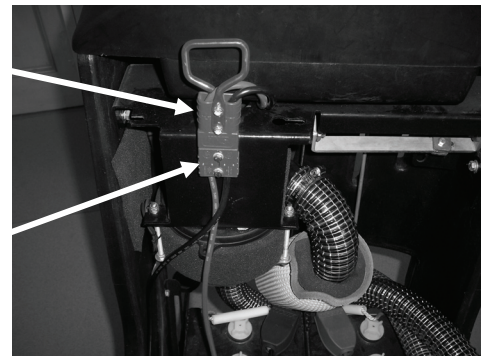

3) BATTERY CHARGE LEVEL INDICATOR

The battery indicator is digital with 4 display levels and a flashing one. The numbers, which appear on the display, show the approximate charge level. 4 represents a full charge and 0 represents discharged and the batteries must be recharged.

NOTE: The brush motor automatically switches off after the battery indicator light begins to flash. You will be able run the vacuum motor and finish drying any wet areas.

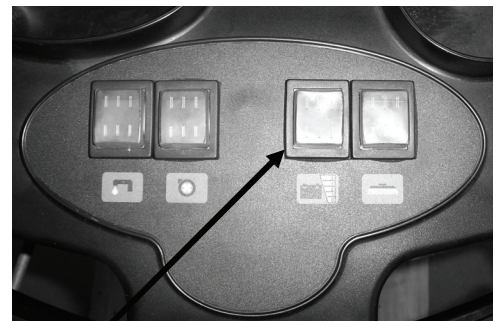

Battery Charge
Indicator



PACIFIC

MACHINE PREPARATION

4) SQUEEGEE ASSEMBLY INSTALLATION

The squeegee is assembled to the machine by lifting the locking latches and sliding the squeegee assembly onto the 2 posts at the rear of the squeegee swing arm. Push on the locking latches down. Lower the squeegee and install vacuum hose over vacuum outlet on squeegee assembly. The hose should be located to the rear of the lifting cable.

Vacuum
Outlet

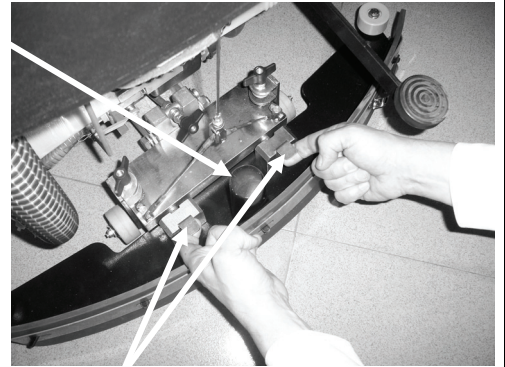

Locking Latches

5) ADJUSTING SQUEEGEE HEIGHT

The height from floor to squeegee should be adjusted based on blade wear. Rotate the adjusting knobs counter-clockwise to lower squeegee and clockwise to lift it.

NOTE: Rotate the right and left adjusting knobs until the squeegee is positioned parallel to the floor.

Height
Adjusting
Knobs

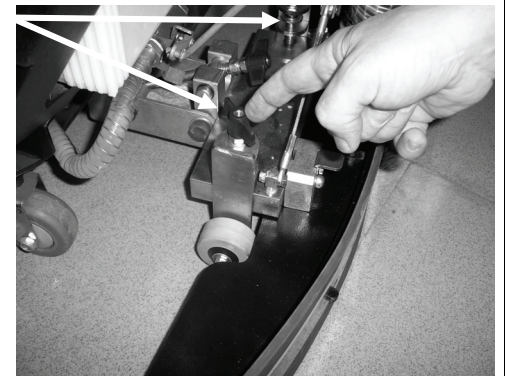

6) ADJUSTING SQUEEGEE INCLINATION

During operation the rear squeegee blade is most efficient when bent backwards roughly $3/16^{\text{ths}}$ to $5/16^{\text{ths}}$ of an inch along its entire length. To increase the blade bending in the center of the squeegee, tilt the squeegee body backward by turning the adjuster knob counter-clockwise. Conversely, turn the adjuster knob clockwise to increase the bending at the outside edges of squeegee blade.

Inclination
Adjusting
Knob

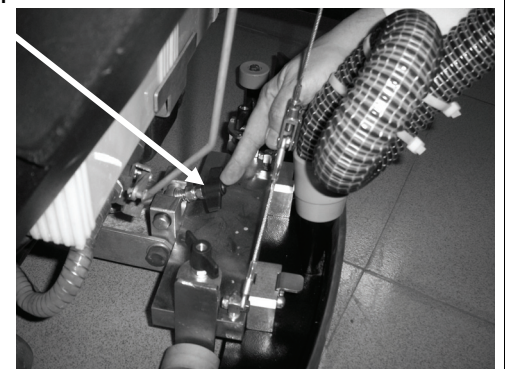



PACIFIC MACHINE PREPARATION

7) RECOVERY TANK

Open the lid and confirm the following connections are secure:

- The vacuum cover is securely attached. Align the notches and rotate the cover clockwise to close. The vacuum hose must also be attached.
- Confirm that the squeegee hose is properly connected.
- Confirm that the drain hose plug, which is located at the front of the machine, is closed.

Vacuum
Cover

Squeegee
Hose

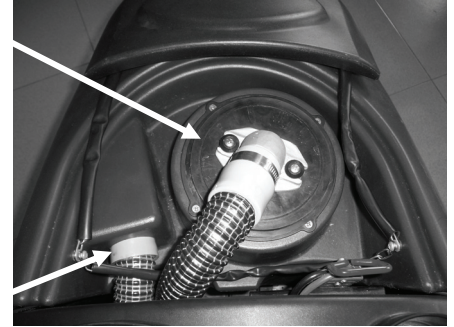

8) SOLUTION WATER

Fill the solution tank with clean water at a temperature not higher than 50°C / 122°F. Add the proper concentration of liquid detergent by following the manufacturer instructions. Excess foam in the recovery tank can damage the vacuum motor, so use only the minimum amount of detergent necessary. Reassemble the cover.



WARNING! Always use low foaming detergent. Adding antifoam liquid into the recovery tank before cleaning will also help prevent foaming.

NEVER USE ACID, BLEACH or AMMONIA

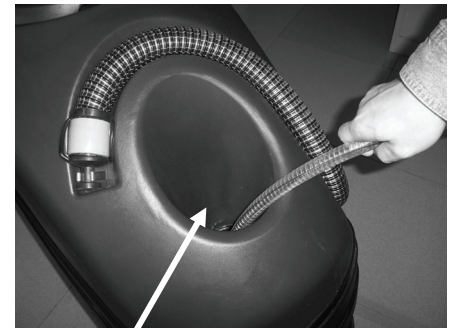

Solution Tank
Fill Opening

9) BRUSH INSTALLATION

- Lift the brush base by depressing the foot level at the rear of the machine.
- Place the brushes under the base. Align the brush lugs with the holes in the brush plate. Insert the brushes into the plate and turn each brush so the lugs are pushed toward their retaining springs, until locked. The photo shows the directions to rotate the brushes to lock them into operating position.

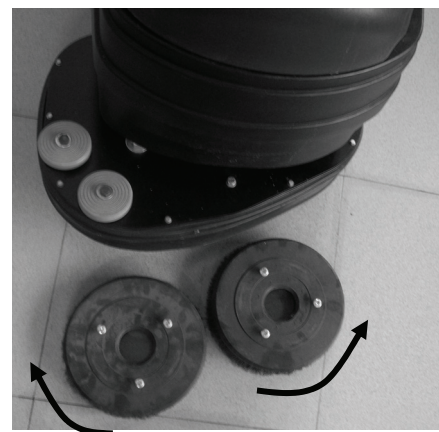



PACIFIC MACHINE PREPARATION

10) SPLASH GUARD INSTALLATION

- a) Wrap splash guard around the brush deck base.
- b) Place band clamp over the front band clamp stud.
- c) Pull band clamp around brush deck base and place band clamp spring over rear band clamp stud.
- d) Repeat process on opposite side of brush deck base.

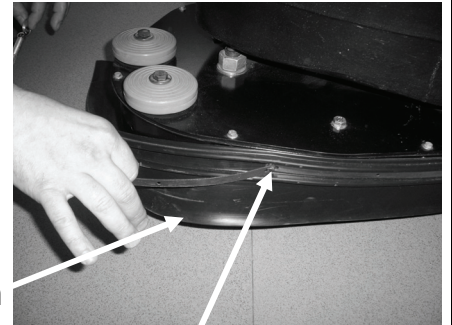

Splash
Guard

Front Band Clamp
Stud

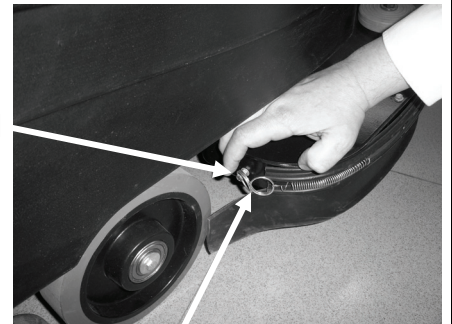

Rear Band
Clamp Stud

Band Clamp Spring

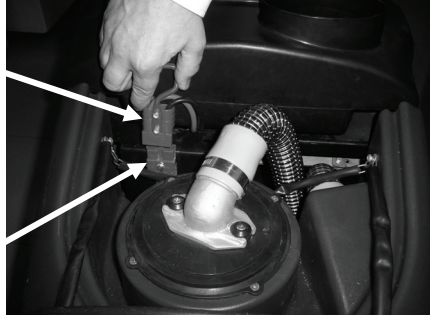
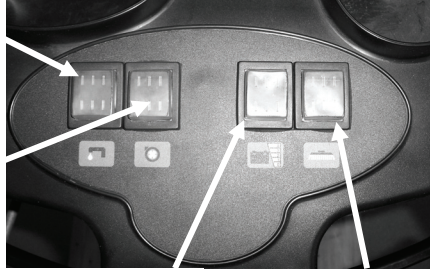
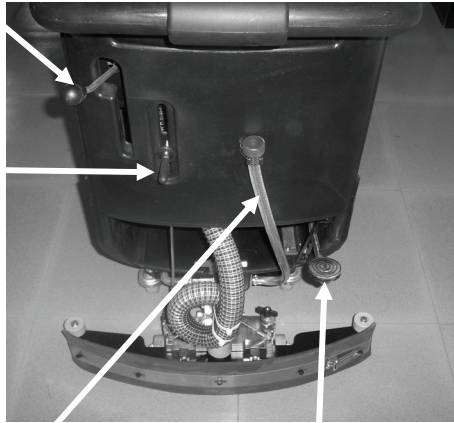

PACIFIC MACHINE OPERATION

<p>1) Connect machine connector to the battery connector.</p>	<p>Machine Connector</p> <p>Battery Connector</p> 
<p>2) Turn on the brush motor switch. Battery charge indicator will illuminate indicating the charge level of the batteries. If the indicator is flashing the batteries need to be charged. Please note that the scrubbing brushes will not rotate until the hand switch lever is engaged.</p> <p>3) Turn on the water solenoid valve switch.</p> <p>4) Turn on the vacuum motor switch.</p>	<p>Water Solenoid Switch</p> <p>Vacuum Motor Switch</p> <p>Battery Charge Indicator</p> <p>Brush Motor Switch</p> 
<p>5) Adjust the flow rate of the cleaning solution with lever. Moving the solution flow control lever downward increase the flow rate and raising the lever decreases the flow rate. There should be enough solution to wet the floor uniformly, but not so much that the water gets past the splash guard. Remember that the correct solution quantity depends on the type of floor, the dirt level and the scrubbing speed.</p> <p>6) Release and raise the brush base lift lever to lower the brush base.</p> <p>7) Lower the squeegee using the squeegee lift lever.</p>	<p>Squeegee Lift Lever</p> <p>Solution Flow Control Lever</p> <p>Solution Tank Drain Hose</p> <p>Brush Base Lift Lever</p> 



PACIFIC MACHINE OPERATION

8) SCRUBBING

This machine is equipped with brush assist propulsion. Depress the handle switch lever. The scrub brushes will begin to rotate and solution will begin to flow. During the first few yards of operation, check that the quantity of the cleaning solution is sufficient to wet the floor and that the squeegee dries the floor surface.



WARNING! Always lift the squeegee when moving backwards.

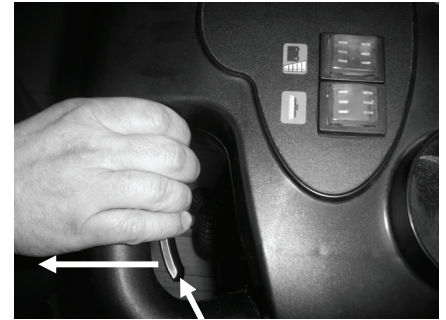

Handle Switch
Lever

9) OVER FILL PROTECTION

The machine is equipped with a float that stops the vacuum exhaust air flow when the recovery tank is full. Vacuum motor does not stop operating but the vacuum exhaust air flow rate is greatly reduced. When this occurs, empty the recovery tank by removing the drain plug on the drain hose and then empty the recovery tank.



WARNING! Use gloves for protection from contact with dangerous solutions.

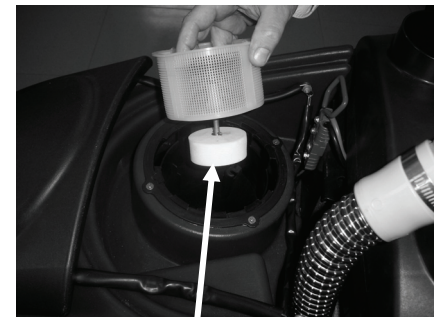

Float



Drain Plug



PACIFIC

UPON COMPLETION OF MACHINE USE

After finishing your work and before any type of maintenance is done, it is necessary to do the following:

- 1) Close the water valve by raising the solution flow control lever.
- 2) Raise the brush base by stepping down locking the brush base lift lever. To lock the lever move your foot to the right while the lever is pressed down.
- 3) Lift the squeegee by raising the squeegee lift lever and locking it by moving the lever to the left.



WARNING! The squeegee blades can be damaged if the squeegee is not raised during storage or transport.

Squeegee Lift Lever

Solution Flow Control Lever

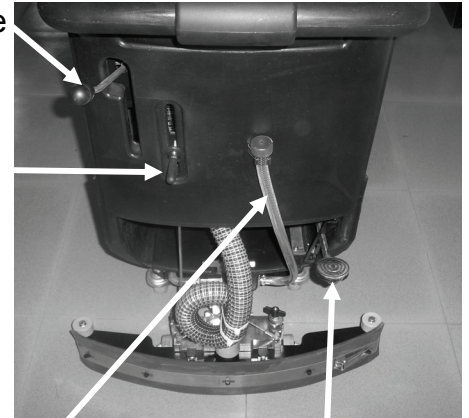

Solution Tank Drain Hose

Brush Base Lift Lever

- 4) Switch off the water solenoid valve switch.
- 5) Switch off the brush motor switch.
- 6) Switch off the vacuum motor switch.
- 7) Transport the machine to the location where the recovery tank should be emptied.

Water Solenoid Switch

Vacuum Motor Switch

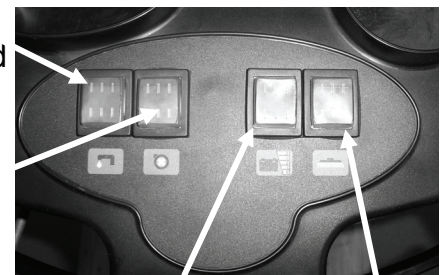

Battery Charge Indicator

Brush Motor Switch

- 8) Remove the drain hose at the front of the recovery tank.
- 9) Remove the drain plug and empty the recovery tank.



WARNING! Use gloves for protection from contact with dangerous solutions.

- 10) Remove the brushes or pad drivers and clean them with clear water.



Drain Plug



PACIFIC

DAILY MACHINE MAINTENANCE

CLEANING THE RECOVERY TANK

- 1) Empty the recovery tank by removing the drain plug from the drain hose.



WARNING: Use gloves for protection from contact with dangerous solution.



Drain Plug

- 2) Lift the cover of the recovery tank.
- 3) Take off the vacuum cover by rotating it counter clockwise.
- 4) Remove the filter and its housing.
- 5) Rinse the tank with clean water.

Vacuum Cover

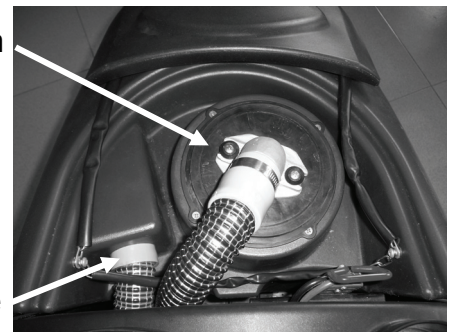

Squeegee Hose

CLEANING THE VACUUM FILTER

- 6) Lift the cover.
- 7) Take off the vacuum cover by rotating it counter clockwise.
- 8) Remove the filter and its housing.
- 9) Use clear water to clean the walls and the bottom of the filter.
- 10) Remove the filter and its housing.
- 11) Wash all components thoroughly.
- 12) Reassemble repeating the above operations in reverse.





PACIFIC

DAILY MACHINE MAINTENANCE

CLEANING THE SQUEEGEE

To obtain the best drying results, keep the squeegee clean. To clean the squeegee it is necessary to:

- 13) Remove the vacuum hose from the squeegee.
- 14) Lift locking latches. Remove the squeegee assembly by pulling rearward.
- 15) Clean the inside of the squeegee thoroughly.
- 16) Clean the squeegee blades thoroughly.
- 17) Reassemble.

Vacuum
Outlet

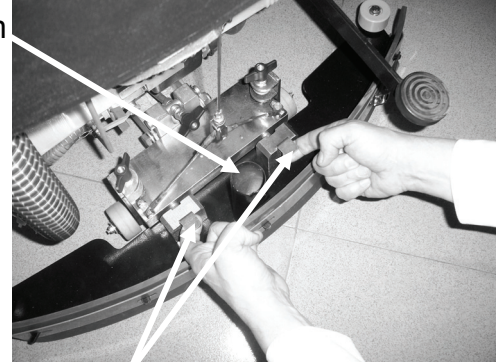

Locking Latches

REPLACING THE SQUEEGEE BLADES

Check the squeegee blades for wear and if necessary, change them. To replace the squeegee blades:

- 18) Remove the squeegee vacuum hose from its port.
- 19) Lift locking latches and pull squeegee assembly rearward.
- 20) Release the band clamps by lifting the band clamp latch.
- 21) Remove squeegee blades.
- 22) Rotate or replace the blades. Please note that the squeegee has 4 useable edges so you may be able to rotate squeegee blades.
- 23) To reassemble the squeegee, repeat the above operations in reverse.



Band
Clamp
Latch

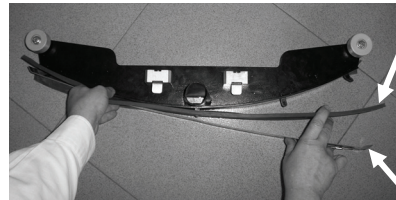

Squeegee
Blade

Band
Clamp

Band
Clamp
Latch



Squeegee
Blade

Band
Clamp





PACIFIC DAILY MACHINE MAINTENANCE

BRUSH / PAD DRIVER REMOVAL

- 24) Lift the brush base by depressing the foot level at the rear of the machine.
- 25) The photo shows the directions to rotate the brushes to unlock them from the auto scrubber. Clean the brushes with clear water.

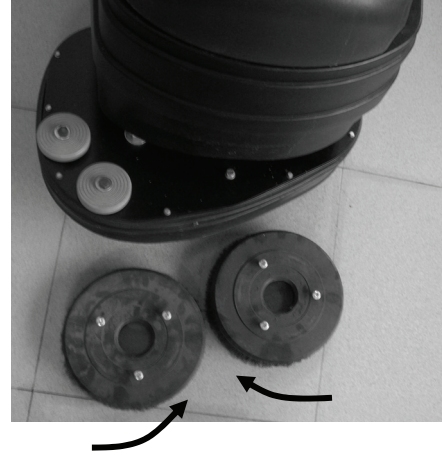



PACIFIC

WEEKLY MACHINE MAINTENANCE

CLEANING THE SQUEEGEE HOSE

To obtain the best drying results, keep the squeegee hose clean. To clean the squeegee hose it is necessary to:

- 1) Take off the vacuum hose from its vacuum port on the squeegee.
- 2) Remove the other end of the vacuum hose from the recovery tank.
- 3) Wash the inner part of the hose with clean water.
- 4) Reassemble.



WARNING: Do not wash the hose that goes from the vacuum motor to the vacuum cover.

Do Not Wash Vacuum Cover Hose

Wash Squeegee Hose

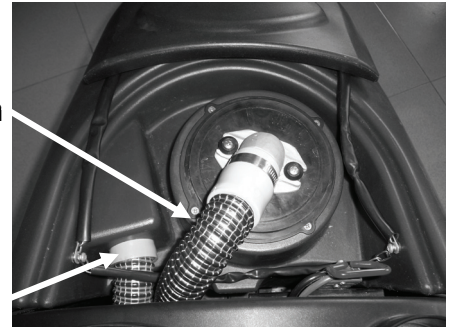

SOLUTION TANK CLEANING

- 5) Remove the fill cap from the solution tank.
- 6) Rinse with clear water.
- 7) Remove the solution tank drain hose and cap at rear of machine and empty the solution tank.



WARNING: Use gloves for protection from contact with dangerous solution.

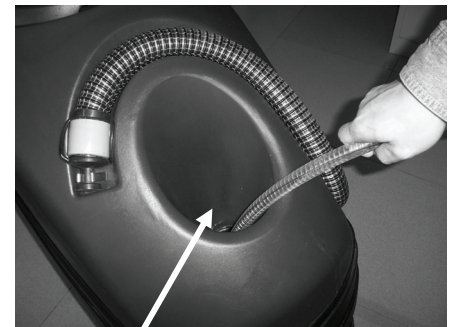

Solution Tank Fill Opening

IN-LINE FILTER CLEANING

- 8) Drain solution tank.
- 9) Turn off solenoid valve.
- 10) Loosen set screw on in-line filter but do not remove.
- 11) Pull rear hose rearward and separate in-line filter into 2 pieces.
- 12) Remove the filter element and clean with clear water.
- 13) Reassemble.



WARNING: Use gloves for protection from contact with dangerous solution.

In-Line Filter

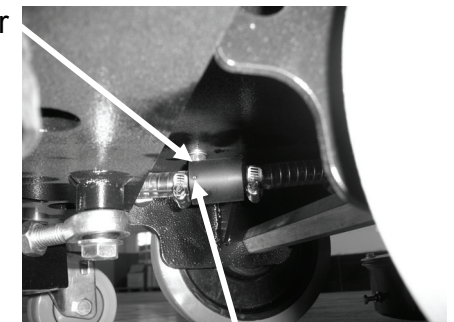

Set Screw

Filter Element

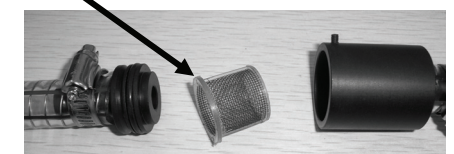



PACIFIC WATER SOLENOID MAINTENANCE

In the event that the water solenoid begins to leak when turned off debris must be cleared at the valve seat. To gain access the water solenoid the scrub deck must be disassembled from the lifting arms. Remove the 3 bolts shown in the photo to release the scrub deck.

Remove Water Solenoid

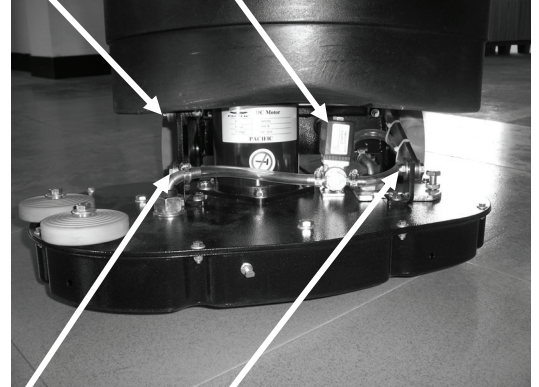

Remove Remove



PACIFIC TROUBLE SHOOTING GUIDE

1) INSUFFICIENT WATER TO THE BRUSHES

- a) Make sure the solution flow control valve is open.
- b) Confirm that there is water in the solution tank.
- c) Make sure solution dispensing tubes are not clogged or obstructed.

Solution
Flow
Control
Lever

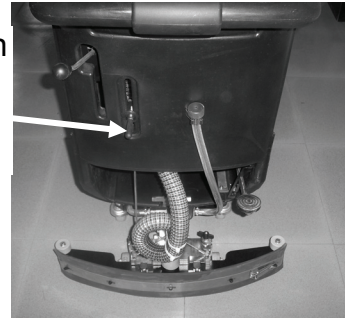

2) THE MACHINE DOES NOT CLEAN SATISFACTORILY

- a) Check the condition of the brushes or pads and replace them if necessary.
- b) The brushes should be replaced when the bristles reach a length of 5/8 inches (15mm).

3) THE SQUEEGEE DOES NOT DRY THE FLOOR WELL

- a) Check that the squeegee blades are clean.
- b) Adjust the inclination of the squeegee.
- c) Confirm the vacuum hose is correctly fitted into its port in the recovery tank and free from obstructions.
- d) Replace the squeegee blades if worn.
- e) Check that the vacuum motor switch is on.
- f) Check the squeegee height adjustment (see "MACHINE PREPARATION" section).

4) EXCESSIVE FOAM PRODUCTION

- a) Check that a low foaming detergent has been used. If required, add a small quantity of defoamer liquid to the recovery tank. More foam is generated when a floor is lightly soiled. Use less detergent if this is the case.



PACIFIC

Drawing 1			
PART NUMBER	DESCRIPTION & SPECIFICATION	QTY	NOTE
840302	Brush Base Idler Arm Adjuster	1	EPOXY PAINT
840904	Carbon Brush	2	
841102	Wheel Bushing	2	BRASS
842003	Hose Clamp	1	SS
842004	Hose Clamp	4	SS
842006	Clamp - Band	2	SS
842303	Base Cover	1	EPOXY PAINT
843302	Fitting Barbed	1	
843306	Fitting Barbed	2	
843307	Fitting	1	
843601	Z210 Splash Guard - Blue	1	
845003	Key - Motor Shaft	1	
845201	Brush Motor	1	
845604	Solenoid Valve Mount	1	ZINC
846904	Pulley	1	ZINC
848402	Stud Screw	1	SS
849003	Tubing	1	
849010	Tubing	1	
849401	Solenoid Valve	1	
849701	Wheel	2	
849801	Thrust Washer	1	ZINC
880550	Adjuster - Bolt	1	ZINC
881150	Bushing	1	
881151	Bushing	1	ZINC
887350	Ring	2	ZINC
888336	Spring	2	ZINC
888342	Spring	1	ZINC
920653	M6 Nyloc Hex Nut Zinc	2	ZINC
920658	Nut Flange M5 Zinc	6	ZINC
924032	M5 Nyloc Hex Nut Zinc	9	ZINC
924033	NyLoc Hex Nut M8 Zinc	6	ZINC
924055	Lock Nut M10	1	ZINC
964103	Hex Bolt-Full M8x45 Zinc	2	ZINC
964116	Hex Bolt M6x20 Zinc	3	ZINC
964225	Hex Bolt M5X20 Zinc	2	ZINC
964239	Hex Bolt M8x25 Zinc	4	ZINC
964335	Hex Bolt M5X16 Zinc	9	ZINC
964423	Hex Bolt M6X12 Zinc	2	ZINC
980064	M10 Washer Flat Zinc	1	ZINC
980665	M6 Flat Washer Zinc	6	ZINC
980672	M6 Lock Washer Zinc	3	ZINC
980679	M8 Washer Flat Zinc	10	ZINC
980684	M8 Washers Flat L Zinc	4	ZINC
980685	M5 Washer Flat Zinc	18	ZINC



Brush Base Assembly

Drawing 2

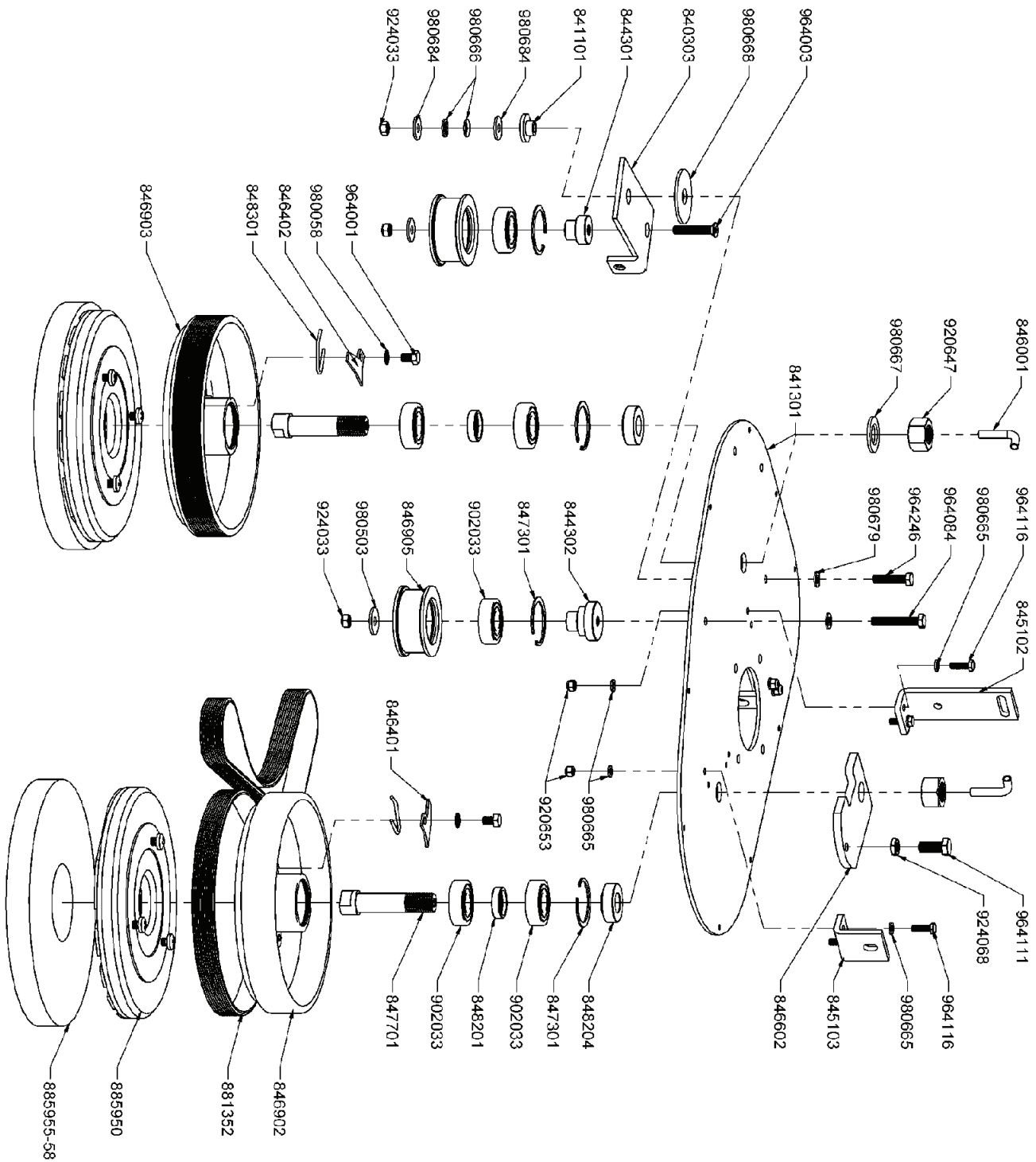



PACIFIC

Drawing 2			
PART NUMBER	DESCRIPTION & SPECIFICATION	QTY	NOTE
840303	Idler Arm	1	EPOXY PAINT
841101	Bushing	1	
841301	Brush Base Deck	1	EPOXY PAINT
844301	Bearing Hub	1	ZINC
844302	Bearing Hub	1	ZINC
845102	Brush Base Dual Lift Link	1	EPOXY PAINT
845103	Brush Base Lift Link	1	EPOXY PAINT
846001	Pipe	2	
846401	Left Spring Retaining Plate	1	ZINC
846402	Right Spring Retaining Plate	1	ZINC
846602	Plate	1	ZINC
846902	Brush Clutch Pulley	1	
846903	Brush Clutch Pulley	1	
846905	Idler Pulley	2	ZINC
847301	Reataining Ring 50 mm	4	
847701	Brush Pulley Shaft	2	BLACK OXIDE
848201	Bearing Spacer	2	ZINC
848204	Spacer	2	ZINC
848301	Brush Retaining Spring	2	ZINC
881352	210 Brush Drive Belt	1	
885950	Pad Driver 10 Inch	2	
902033	Bearing	6	
920647	Hex Nut M20 Zinc	2	ZINC
920653	M6 Nyloc Hex Nut Zinc	4	ZINC
924033	NyLoc Hex Nut M8 Zinc	3	ZINC
924068	Hex Nut M10 Thin Zinc	1	ZINC
964001	Hex Bolt M8x12	2	ZINC
964003	Screw Flat Head Torx Drive M8x45	1	ZINC
964084	Hex Bolt-Full M8X50 Zinc	1	ZINC
964111	Hex Bolt M10X25 Zinc	1	ZINC
964116	Hex Bolt M6x20 Zinc	4	ZINC
964246	Hex Bolt M8x35 Zinc	1	ZINC
980058	Washer Star Lock M8	2	ZINC
980503	M8 Washer XL Flat Zinc	2	ZINC
980665	M6 Flat Washer Zinc	8	ZINC
980666	Spring Washer M8x18	2	
980667	Washer M20x39 Flat Zinc	1	ZINC
980668	Washer - Wide M16x56x3Thk	1	
980679	M8 Washer Flat Zinc	2	ZINC
980684	M8 Washers Flat L Zinc	2	ZINC
885955-58	10 Inch Scrub Pad	2	



PACIFIC

Drawing 3			
PART NUMBER	DESCRIPTION & SPECIFICATION	QTY	NOTE
840301	Brush Deck Lift Idler Arm	1	ZINC
840306	Brush Deck Lift Arm ASM	1	ZINC
841105	Bushing	2	BRASS
842003	Hose Clamp	2	SS
842005	Clamp Bar	1	SS
842306	Pedal Cover	1	
842701	Metal Disc	1	ZINC
843202	Z210 Main Frame Weldment	1	EPOXY PAINT
843314	In Line Filter Outer Housing	1	
843315	In Line Filter Inner Housing	1	
843316	In Line Filter Element	1	
843602	Splash Guard	1	
843801	Grommet	1	
845801	O-Ring 21.2x2.65	1	
847001	Brush Lift - Pivot Block	6	
847704	Wheel Shaft	1	ZINC
848211	Wheel Spacer	2	ZINC
848302	Spring	1	ZINC
849001	Tubing	1	
849002	Tubing	1	
849703	Castor	2	
849704	Main Wheel	2	
920648	M12 Nyloc Hex Nut Zinc	3	ZINC
920649	Hex Nut M8 Zinc	4	ZINC
920653	M6 Nyloc Hex Nut Zinc	6	ZINC
924033	NyLoc Hex Nut M8 Zinc	7	ZINC
964007	Hex Bolt M8X40 Zinc	1	ZINC
964083	Hex Bolt M8X30 Zinc	2	ZINC
964116	Hex Bolt M6x20 Zinc	2	ZINC
964182	Screw M4x10 Pan Head Zinc	4	ZINC
964209	Hex Bolt M6X16 Zinc	4	ZINC
964230	Hex Bolt M12x65 Zinc	1	ZINC
964400	Flat Head Soc Hex Screw M6x16 Zinc	1	ZINC
964415	Hex Bolt M6x45 Zinc	6	ZINC
964437	Screw - SHCS M8x40 Zinc	2	ZINC
964442	Slotted Set Screw Cone Point M3x6	1	BLACK OXIDE
980043	Washer Flat M12	5	ZINC
980501	M6x22 OD Washer Flat Zinc	2	ZINC
980665	M6 Flat Washer Zinc	14	ZINC
980670	M6 External Lock Washer Zinc	2	ZINC
980671	M6 Washer Flat XL Zinc	2	ZINC
980672	M6 Lock Washer Zinc	4	ZINC
980676	M8 Washer - Plastic	2	
980679	M8 Washer Flat Zinc	8	ZINC
980684	M8 Washers Flat L Zinc	5	ZINC



Squeegee Arm Assembly

Drawing 4

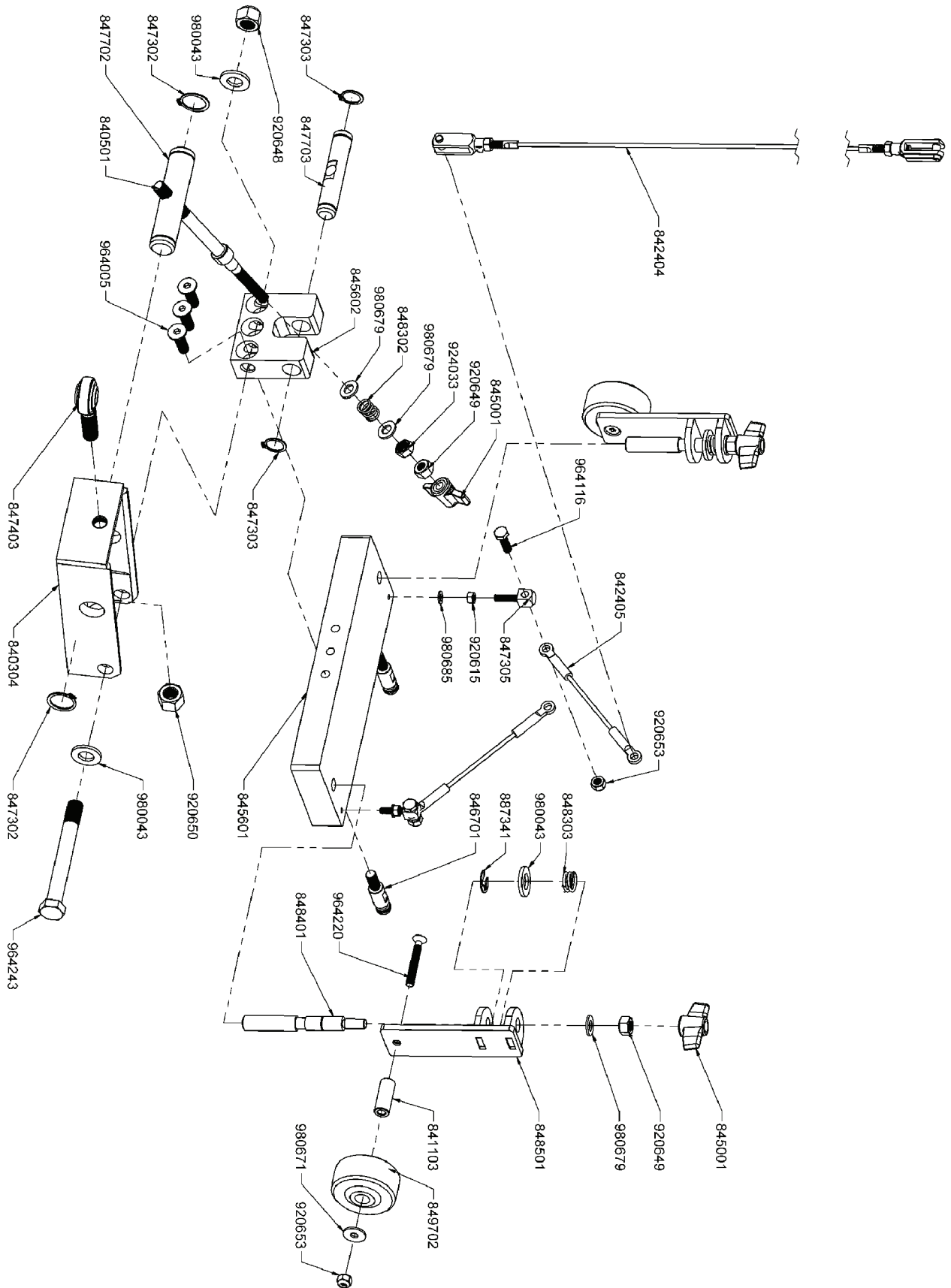



PACIFIC

Drawing 4			
PART NUMBER	DESCRIPTION & SPECIFICATION	QTY	NOTE
840304	Squeegee Link Arm Weldment	1	EPOXY PAINT
840501	Squeegee Adjuster Bolt ASM	1	ZINC
841103	Wheel Bushing	2	
842404	Squeegee Lift Cable	1	
842405	Squeegee Lift Cable	2	
845001	Adjustment Knob	3	
845601	Squeegee Mount Base	1	ZINC
845602	Squeegee Mount Base Pivot	1	ZINC
846701	Squeegee Attachment Pin	2	ZINC
847302	Retaining Ring 20mm x 1.2mm THK	2	BLACK OXIDE
847303	Retaining Ring 15mm x 1.0mm THK	2	BLACK OXIDE
847305	Squeegee Lift Ring	2	ZINC
847403	Rod End Male M12 Zinc	1	ZINC
847702	Squeegee Adjuster Front Shaft	1	ZINC
847703	Squeegee Adjuster Rear Shaft	1	ZINC
848302	Spring	1	ZINC
848303	Spring - Squeegee Adjust	2	ZINC
848401	Squeegee Wheel Adjusting Stud	2	SS
848501	Wheel Strut Upright	2	ZINC
849702	Wheel	2	
887341	E-Ring 9 mm ID	2	BLACK OXIDE
920615	Hex Nut M5 Zinc	2	ZINC
920648	M12 Nyloc Hex Nut Zinc	1	ZINC
920649	Hex Nut M8 Zinc	3	ZINC
920650	Hex Nut M12 Zinc	1	ZINC
920653	M6 Nyloc Hex Nut Zinc	4	ZINC
924033	NyLoc Hex Nut M8 Zinc	1	ZINC
964005	Flat Head Soc Hex Screw M8X25	3	ZINC
964116	Hex Bolt M6x20 Zinc	2	ZINC
964220	M6x45 Flat Hd Phil Zinc	2	ZINC
964243	Hex Bolt M12x100 Lg Zinc	1	ZINC
980043	Washer Flat M12	4	ZINC
980671	M6 Washer Flat XL Zinc	2	ZINC
980679	M8 Washer Flat Zinc	4	ZINC
980685	M5 Washer Flat Zinc	2	ZINC



Squeegee Assembly

Drawing 5

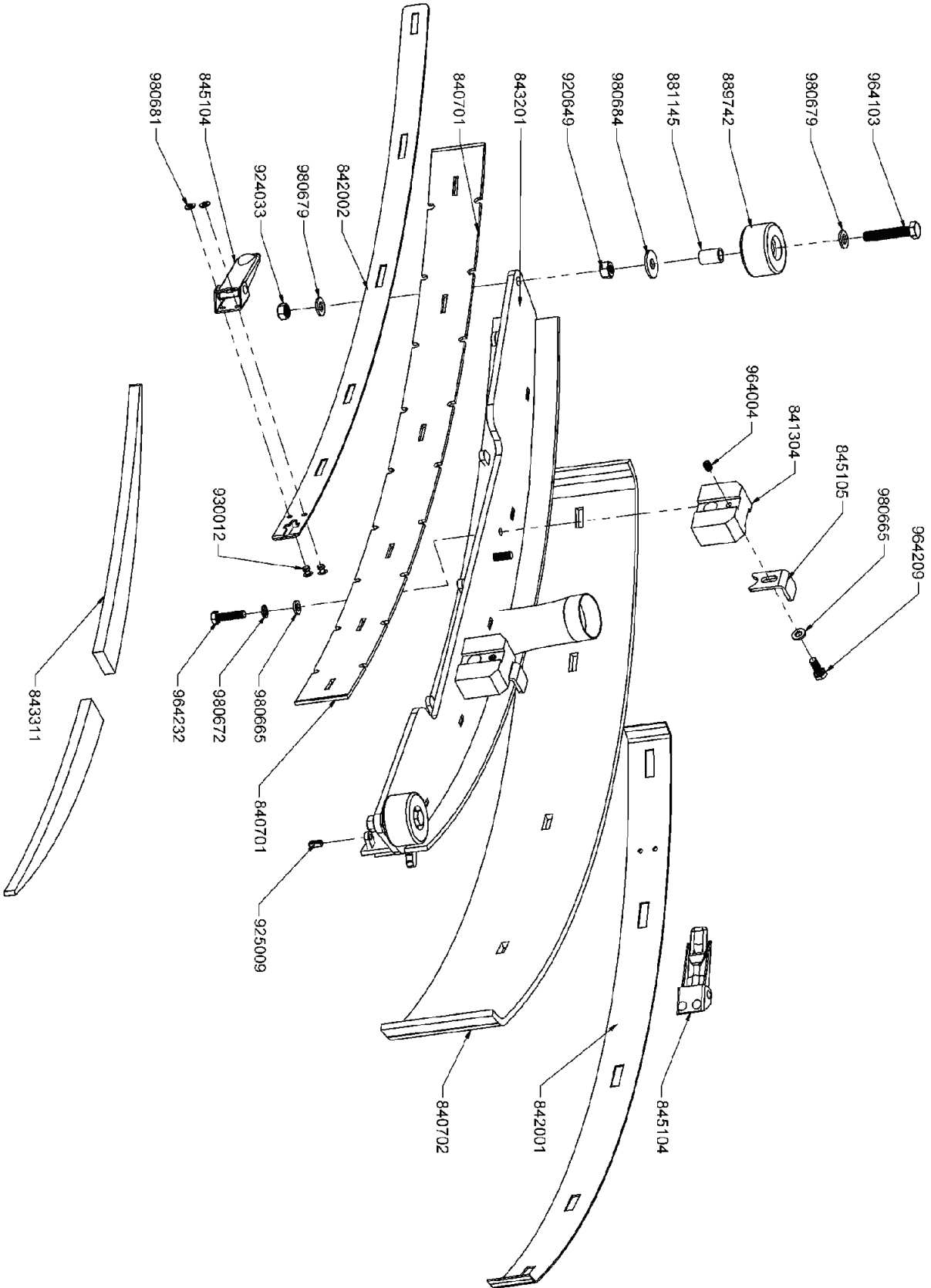



PACIFIC

Drawing 5			
PART NUMBER	DESCRIPTION & SPECIFICATION	QTY	NOTE
840701	Squeegee Blade Front	1	
840702	Squeegee Blade Rear	1	
841304	Squeegee Attachment Block	2	ZINC
842001	Band Clamp-Rear	1	SS
842002	Band Clamp-Front	1	SS
843201	Squeegee Frame Weldment	1	EPOXY PAINT
843311	Filler - Z210 Squeegee	2	
845104	Latch ASM	2	ZINC
845105	Squeegee Attachment Block Latch	2	ZINC
881145	Wheel Bushing	2	BRASS
889742	Wheel 45 Dia	2	
920649	Hex Nut M8 Zinc	2	ZINC
924033	NyLoc Hex Nut M8 Zinc	2	ZINC
925009	Roll Pin M5.5x12 SS	1	SS
930012	Revit M4x8 Lg Oval Head Semi-Tubular	4	
964004	Hex Set Screw M6X8	2	BLACK OXIDE
964103	Hex Bolt-Full M8x45 Zinc	2	ZINC
964209	Hex Bolt M6X16 Zinc	2	ZINC
964232	Hex Bolt M6x25 Zinc	4	ZINC
980665	M6 Flat Washer Zinc	6	ZINC
980672	M6 Lock Washer Zinc	4	ZINC
980679	M8 Washer Flat Zinc	4	ZINC
980681	Washer M4 Flat Zinc	4	ZINC
980684	M8 Washers Flat L Zinc	2	ZINC



PACIFIC

Drawing 6			
PART NUMBER	DESCRIPTION & SPECIFICATION	QTY	NOTE
841302	Rear Battery Bracket	1	ZINC
841303	Side Battery Bracket	1	ZINC
842003	Hose Clamp	2	SS
842705	Sound Deadener	1	
843308	Fitting Barbed	1	
843309	Fitting Barbed	1	
843310	Filter Basket	1	
843401	Battery Plastic Gasket	1	
843402	Side Battery Gasket	1	
843406	Conical Tank Gasket	1	
844702	Fitting	1	
845106	Brush Deck Lift Latch	1	EPOXY PAINT
845107	Lever - Valve	1	ZINC
845111	Z Series Water Control Label	1	
845113	Z Series Squeegee Lift Label	1	
846403	Plate Wire Retaining	3	
846603	Water Valve Limit Plate	1	
847401	Rod - Connecting	1	ZINC
848302	Spring	1	ZINC
848601	Z210 Solution Tank	1	
849007	Drain Tubing - Solution Tank	1	
849402	Valve	1	
882440	Hook	1	SS
885044	Knob	1	
886852	Cap	1	
920615	Hex Nut M5 Zinc	1	ZINC
924051	M5 Retaining Nut	1	ZINC
925008	Cotter Pin M2x10	1	SS
964127	Screw M4X8 Pan Head Zinc	1	ZINC
964224	M5.5X16 Pan Head Plastite Screw	4	ZINC
964228	M3x9.5 Pan Head Plastite Screw	6	ZINC
964231	ST M4.2X12 Pan HD PL Zinc	2	ZINC
964398	Hex Bolt Full-THD M6x25 SS	1	SS
964423	Hex Bolt M6X12 Zinc	2	ZINC
964435	Hex Bolt M8x90 Zinc	4	ZINC
980060	Plastic Washer M5	1	
980504	M6x30 OD Washer Flat Plastic	2	
980665	M6 Flat Washer Zinc	2	ZINC
980671	M6 Washer Flat XL Zinc	4	ZINC
980672	M6 Lock Washer Zinc	2	ZINC
980679	M8 Washer Flat Zinc	1	ZINC
980680	Lock Washer M4 Zinc	1	ZINC
980682	M3 Washer Flat Zinc	6	ZINC
980684	M8 Washers Flat L Zinc	4	ZINC
980685	M5 Washer Flat Zinc	1	ZINC
980702	M4 Large Flat Washer Zinc	1	ZINC



PACIFIC

Drawing 7			
PART NUMBER	DESCRIPTION & SPECIFICATION	QTY	NOTE
505172	Dolphin Dome Label-Large	1	
842007	Hose Clamp	1	
842304	Z210 Recovery Tank Cover	1	
842305	Solution Tank Cover	1	
842403	Chain	2	SS
842410	Chain For Lift	1	
843405	Tank Gasket	1	
844101	Z210 Recovery Tank Vacuum Hose	1	
844102	Z210 Squeegee Vacuum Hose	1	
844103	Z210 Drain Hose	1	
845110	Z Series Recovery Tank Cover Label	1	
845131	Label For Lifting	1	
846801	Plug - Solution Tank Fill	1	
847304	Ring - Filter Holder	1	
848101	Sleeve	2	
848102	Sleeve For Lift	1	
848602	Z210 Recovery Tank	1	
849004	Tubing	1	
882440	Hook	1	SS
882442	Vacuum Outlet Port	1	
883343	Filter Basket	1	
883344	Float	1	
883441	Gasket	1	
883442	Gasket	1	
883446	Gasket	1	
886841	Filter Cover	1	
887440	Float Rod	1	SS
888551	Splash Protector	1	
924045	M5 Nyloc Hex Nut Stainless	2	SS
925603	Cotter Pin M2x20	2	SS
964063	FLHD Screw Ph Drive SS 4.2x13	4	SS
964105	Oval HD PHL Screw M5x25 SS	2	SS
964231	ST4.2X13 Pan HD PL Zinc	2	ZINC
964438	Screw M5x16 Pan Head Zinc	4	ZINC
980060	Plastic Washer M5	2	
980502	M5 x 15OD Flat Washer Zinc	4	ZINC
980675	M6 Flat Washer Stainless	2	SS
980704	M5 Washer Flat SS	2	SS
S611A	Hose Clamp 45mm	3	SS



PACIFIC

Drawing 8			
PART NUMBER	DESCRIPTION & SPECIFICATION	QTY	NOTE
840305	Lever Arm Weldment	1	ZINC
840805	Bracket-Weldment	1	EPOXY PAINT
841104	Bushing	2	BRASS
841305	Lever Bracket	1	ZINC
842014	Hose Clamp 50mm	1	SS
842702	Vacuum Motor Sound Deadener	1	
842703	Vacuum Motor Sound Deadener	1	
842704	Sound Deadener	1	
843801	Grommet	1	
843901	Connector Handle	1	
844104	Vacuum Exhaust Hose	1	
845002	Lever Arm Knob	1	ZINC
845202	24VDC Vacuum Motor - SIX	1	
845603	Muffler	1	
847405	Rod - Connecting	1	ZINC
911441	Connector Male 50A	1	
911442	Connector Female 50A	1	
911531	Hose Clamp	1	
920033	M4 Hexagon Lock Nut	4	ZINC
920653	M6 Nyloc Hex Nut Zinc	6	ZINC
924063	Hex Nut M6 Zinc	4	ZINC
962332	ST M6.3X22 Pan Head Zinc	2	ZINC
964116	Hex Bolt M6x20 Zinc	3	ZINC
964176	Hex Bolt M6X30 Zinc	2	ZINC
964421	Screw M4x25 Pan HD PL Zinc	2	ZINC
964422	Screw M4x20 Pan HD PL Zinc	2	ZINC
964423	Hex Bolt M6X12 Zinc	5	ZINC
980501	M6x22 OD Washer Flat Zinc	2	ZINC
980665	M6 Flat Washer Zinc	18	ZINC
980671	M6 Washer Flat XL Zinc	2	ZINC
980672	M6 Lock Washer Zinc	6	ZINC
980681	Washer M4 Flat Zinc	4	ZINC



Switch Box Assembly

Drawing 9

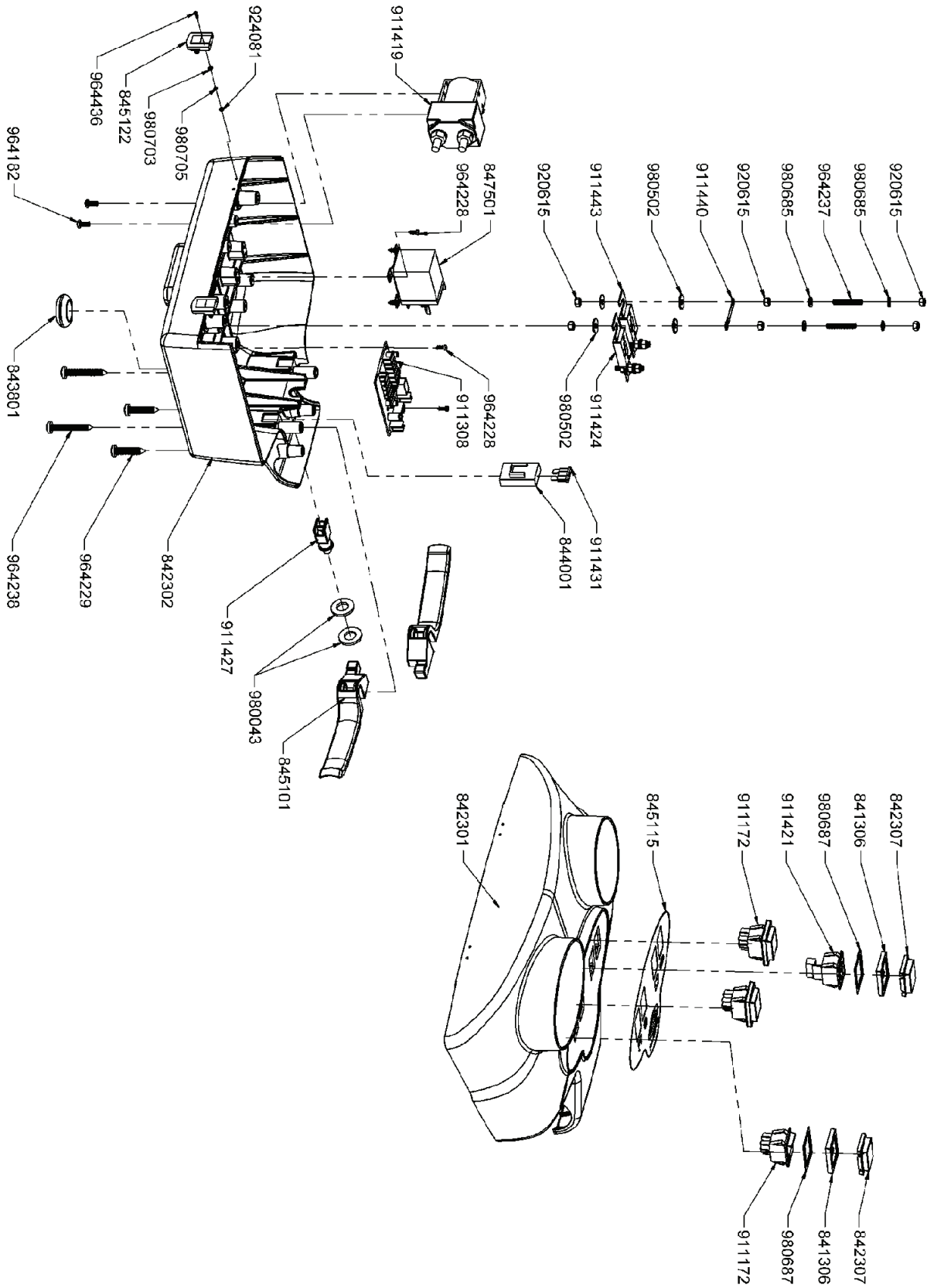



PACIFIC

Drawing 9			
PART NUMBER	DESCRIPTION & SPECIFICATION	QTY	NOTE
841306	Bezel - Rocker Switch	4	
842301	Cover Upper Switch Box	1	
842302	Cover Lower Switch Box	1	
842307	Cover - Rocker Switch	4	
843801	Grommet	1	
844001	Fuse Holder	1	
845101	Scrubber Lever - Switch Box	2	
845115	Z210 Switch Box label	1	
845122	Switch Box Latch	2	
845132	Z210 Switch Box label-China	1	
847501	Traction & Vacuum Motor Relay	1	
911172	Rocker Switch Green	3	
911308	Battery Check Card	1	
911419	Brush Motor Relay	1	
911421	Battery Charge Numeric Indicator	1	
911424	Fuse 30Amp	1	
911427	Microswitch	1	
911431	Fuse 3Amp	1	
911440	Jumper Wire	1	
911443	Fuse 50Amp	1	
920615	Hex Nut M5 Zinc	12	ZINC
924081	Hex Nut M2 Zinc	8	ZINC
964182	Screw M4x10 Pan Head Zinc	2	ZINC
964228	M3 x9.5 Pan Head Plastite Screw	6	ZINC
964229	M6.0x32 Pan Head Plastite Screw	2	ZINC
964237	Set Screw Socket M5X30 Zinc	4	ZINC
964238	Plastite Screw M6x45 Pan HD PL Zinc	2	ZINC
964436	Flat HD PHL Screw M2x8 Zinc	8	ZINC
980043	Washer Flat M12	2	ZINC
980502	M5 x 15OD Flat Washer Zinc	8	ZINC
980685	M5 Washer Flat Zinc	8	ZINC
980687	Special Washer	4	
980703	M2 Flat Washer Zinc	8	ZINC
980705	Spring Lock Washer M2 Zinc	8	ZINC



PACIFIC

Drawing 10		
PART NUMBER	DESCRIPTION & SPECIFICATION	QTY
844505	Wire Harness	1
844506	Wire Harness	1
844507	Wire Harness	1
844508	Wire Harness	1
844509	Wire Harness	1
844510	Wire Harness	1
844511	Wire Harness	1
844512	Wire Harness	1
844513	Wire Harness	1
844514	Wire Harness	1
844515	Wire Harness	1
844516	Wire Harness	1
844517	Wire Harness	1
844518	Wire Harness	1
844519	Wire Harness	1
844520	Wire Harness	1
844521	Wire Harness	1
844522	Wire Harness	1
844523	Wire Harness	1
844526	Wire Harness	1
844527	Wire Harness	1
844528	Wire Harness	1
844529	Wire Harness	1
844530	2 Cables black-red and connector 50A	1
844531	2 Cables black-red and connector 50A	1
845201	Brush Motor	1
845202	24VDC Vacuum Motor - SIX	1
847501	Traction & Vacuum Motor Relay	1
849401	Solenoid Valve	1
911172	Rocker Switch Green	3
911308	Battery Check Card	1
911401	Capacitor 470nF-250V	1
911402	Resistor 220 Ohm	1
911419	Brush Motor Relay	1
911421	Battery Charge Numeric Indicator	1
911424	Fuse 30Amp	1
911427	Microswitch	1
911431	Fuse 3Amp	1
911440	Jumper Wire	1
911443	Fuse 50Amp	1
911490	Butt Connector 6.0mm Yellow	2
911491	Spade Connector Female Ins 6.3x5.0mm Yellow	2
911495	Spade Connector male Ins 6.3x5.0mm Yellow	2
68000154	Cable Bridge	1
72500008	Diode 1N4007	6



PACIFIC WARRANTY POLICY PACIFIC LIMITED WARRANTY

The **Pacific** Z210 has been manufactured, tested and inspected in accordance with specific engineering requirements. This machine is **WARRANTED** to be free from defects in workmanship and materials for periods as follows from the date of purchase.

Ten (10) Years Parts, One (1) Year Labor – Polyethylene Components
Five (5) Years Parts, One (1) Year Labor – Main Frame
Two (2) Years Parts, One (1) Year Labor – Brush Drive Motors
One (1) Year Parts & Labor – All other components unless excluded below

Travel time for warranty repair is authorized for a period of ninety (90) days following the date of sale to the end user, with a maximum of three (3) hours per claim.

This warranty extends to the original user/purchaser and only when used, operated and maintained in accordance with **Pacific** Operating and Maintenance instructions.

This warranty does not apply to certain wear parts and accessories of the machine such as electrical cords, carbon motor brushes, floor brushes, belts, hoses, tools, squeegee blades, etc., nor does it apply to damage or failure caused by improper use, abuse or neglect. Warranty credit of return parts including motors, pumps, etc., is subject to incoming inspection of those items.

To secure repair under this warranty, the following procedure should be taken:

1. After the expiration of the ninety (90) day travel time warranty period, the customer is responsible for warranty travel payment for the inoperative machine or warranted parts must be delivered to the authorized dealer with shipping and delivery charges prepaid. If unable to locate the Dealer, you may contact **Pacific** at the address listed herein for the location of the nearest **Pacific** repair center or agent or for other instructions pertaining to your warranty difficulty.
2. Upon compliance with the above warranty procedure, all warranted repairs will be completed at no additional charge or cost to the user.
3. Only **Pacific** or its authorized dealers and agents may make no charge warranty repairs on this product. All others do so at their own risk.

This warranty limits **Pacific** liability to the repair of the product and/or warranted parts replacement and does not include incidental or consequential damages arising from the use of a **Pacific** machine whether defective or not.

BATTERY WARRANTY

In addition to the terms above, any original equipment **Pacific** battery which becomes unserviceable under normal use within a period of ninety (90) days from the date of sale to the original user will be repaired or replaced with one of equal specification at our option, F.O.B. any authorized **Pacific** sales or service branch, with no charge to user, except transportation costs. After the expiration of the above ninety (90) day period, any battery which fails under normal use will be adjusted to the original user with a new battery of equal specification on a twelve (12) month pro rata basis from the date of purchase. Adjustments will be determined using the then current list price, plus transportation costs. Warranty is rendered null and void if battery is not kept filled to the proper level with **DISTILLED WATER**.

This warranty is in lieu of all other expressed or implied warranties and is extended to the original purchaser/user.