



# PARTS & OPERATING MANUAL

## Z210 PAD ASSIST AUTO SCRUBBER

PLEASE READ THIS BOOK

---

This operator's book has important information for the use and safe operation of this machine. Read this book carefully before using the machine. Keep this book and tell all operators to read the book. If you do not follow the instructions, you can cause an injury or damage equipment, furniture or buildings.

For new books, please download your copy from our website [www.pacificfloorcare.com](http://www.pacificfloorcare.com) or write to:

***Pacific Floorcare***  
*2259 S. Sheridan Drive*  
*Muskegon, MI 49442-6252*

Carefully inspect all components to ensure that there is no concealed freight damage. If such damage is discovered, file a "CONCEALED DAMAGE REPORT" immediately with the delivering carrier.







The contents of this manual are based on the latest product information available at the time of publication. Pacific reserves the right to make changes or improvements without notice.

**Thank you for purchasing a Pacific Floorcare product. Warranty registration will allow us to better serve you over the lifetime of the product. For quick and easy registration, go to: [www.pacificfloorcare.com/Register Product](http://www.pacificfloorcare.com/Register Product).**

## SAFETY INSTRUCTIONS

- 1) You must have training in the operation of the machine before using it. **READ THE INSTRUCTION BOOK.** If you do not understand any instruction, ask your supervisor.
- 2) Make sure all labels, decals, warnings, cautions and instructions are fastened to the machine.
- 3) Read the labels carefully on the machine. Do not cover them for any reason and replace them if damaged.
- 4) Do not operate this machine unless it is completely assembled and inspect the machine carefully before operation.
- 5) Pay close attention to other people and especially children while operating this machine.
- 6) Be a careful driver and do not strike shelving or scaffolding, especially where there is a danger of falling objects.
- 7) Machines can cause an explosion when operated near flammable materials and vapors. Do not use this machine with or near fuels, grain dust, solvents, thinners, or other flammable materials.
- 8) In case of fire, use a powder extinguisher. Do not use water.
- 9) Do not use this machine as a means of transport.
- 10) Do not use acid solutions that could damage the machine or flooring.
- 11) Adjust your speed to the conditions of the floor.
- 12) Do not turn the machine on an incline. Do not stop and leave the machine on a ramp or incline.
- 13) During any maintenance operation disconnect the power supply from the machine.
- 14) Lead acid batteries generate gases that can cause an explosion. Read the instruction manual supplied with the battery charger. Keep sparks and flames away from batteries. **NO SMOKING.** Charge the batteries only in an area with good ventilation.
- 15) Do not use a charger if the power cord is damaged or a charger that is not matched to the machine.
- 16) Always wear eye protection and protective clothing when working near batteries. Remove all jewelry. Do not put tools or other metal across the battery terminals, or on the top of the batteries.
- 17) Maintenance and repairs must be performed by authorized Service Centers only.
- 18) Keep the electrical parts of the machine dry. Do not wash the machine with direct water jets or high pressure, or with corrosive material. For storage, keep the machine in a dry location.
- 19) Water solutions or cleaning materials used with this type of machine can leave wet areas on the floor surface. These areas can cause a dangerous condition for the operator or other persons. Always put **CAUTION** signs near the area you are cleaning.
- 20) Do not reach under shrouds with fingers, hands, or toes when machine is running.

## SYMBOLS USED ON THE AUTOMATIC SCRUBBER

	Water Valve Indicator
	Brush Drive Motor Control Switch
	Vacuum Motor Control Switch
	Battery Charge Indicator
	Squeegee Lift Lever Indicator
	Water Flow Control Indicator

## MACHINE PREPARATION

### 1. UNPACKING THE MACHINE

- a. Take off the outer packaging
- b. The machine is fastened to the pallet with wooden wedges that block the wheels. Remove tie down straps
- c. Using a ramp, pull the machine off the pallet



### 2. BATTERY INSTALLATION

- a. Remove the squeegee hose from the recovery tank
- b. Remove the vacuum cover by rotating it counterclockwise



- c. Remove recovery tank by lifting tank by lift chain at the back of the tank and the drain hose at the front of the tank
- d. Place the batteries in the battery compartment
- e. Connect the battery connector to the machine connector
- f. Replace the recovery tank and reassemble the vacuum cover and squeegee hose



### 3. BATTERY CHARGE LEVEL INDICATOR

The battery indicator is digital with 4 display levels and a flashing one. The numbers, which appear on the display, show the approximate charge level. 4 represents a full charge and 0 represents discharged and the batteries must be recharged.

**NOTE:** The brush motor automatically switches off after the battery indicator light begins to flash. You will be able run the vacuum motor and finish drying any wet areas.

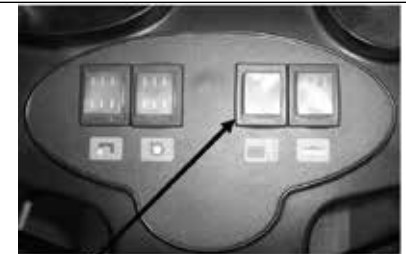

Battery charge indicator

## MACHINE PREPARATION

### 4. SQUEEGEE ASSEMBLY INSTALLATION

The squeegee is assembled to the machine by lifting the locking latches and sliding the squeegee assembly onto the 2 posts at the rear of the squeegee swing arm. Push on the locking latches down. Lower the squeegee and install vacuum hose over vacuum outlet on squeegee assembly. The hose should be located to the rear of the lifting cable

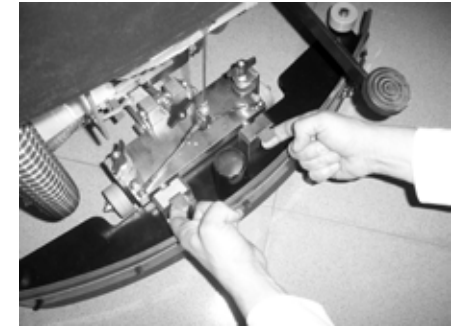

### 5. ADJUSTING SQUEEGEE HEIGHT

The height from floor to squeegee should be adjusted based on blade wear. Rotate the adjusting knobs counter-clockwise to lower squeegee and clockwise to lift it

**NOTE:** Rotate the right and left adjusting knobs until the squeegee is positioned parallel to the floor

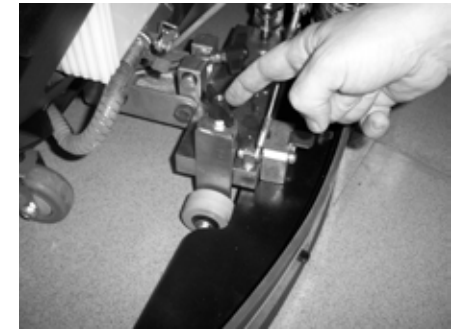

### 6. ADJUSTING SQUEEGEE INCLINATION

During operation the rear squeegee blade is most efficient when bent backwards roughly  $3/16^{\text{th}}$  to  $5/16^{\text{th}}$  of an inch along its entire length. To increase the blade bending in the center of the squeegee, tilt the squeegee body backward by turning the adjuster knob counter-clockwise. Conversely, turn the adjuster knob clockwise to increase the bending at the outside edges of squeegee blade

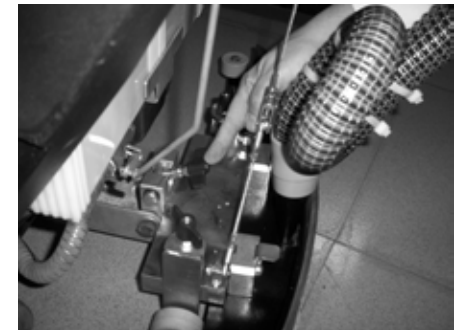

## MACHINE PREPARATION

### 7. RECOVERY TANK

Open the lid and confirm the following connections are secure:

- a. The vacuum cover is securely attached. Align the notches and rotate the cover clockwise to close. The vacuum hose must also be attached
- b. Confirm that the squeegee hose is properly connected
- c. Confirm that the drain hose plug, which is located at the front of the machine, is closed

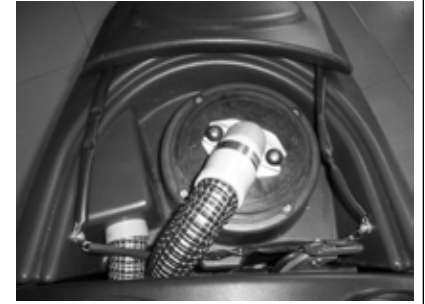

### 8. SOLUTION WATER

Fill the solution tank with clean water at a temperature not higher than 50°C / 122°F. Add the proper concentration of liquid detergent by following the manufacturer instructions. Excess foam in the recovery tank can damage the vacuum motor, so use only the minimum amount of detergent necessary. Reassemble the cover



**WARNING!** Always use low foaming detergent. Adding antifoam liquid into the recovery tank before cleaning will also help prevent foaming



**NEVER USE ACID, BLEACH or AMMONIA**

### 9. BRUSH INSTALLATION

- a. Lift the brush base by depressing the foot level at the rear of the machine
- b. Place the brushes under the base. Align the brush lugs with the holes in the brush plate. Insert the brushes into the plate and turn each brush so the lugs are pushed toward their retaining springs, until locked. The photo shows the directions to rotate the brushes to lock them into operating position

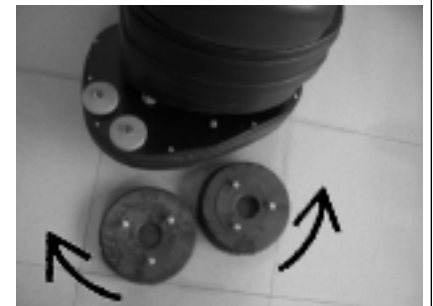

## MACHINE PREPARATION

### 10. SPLASH GUARD INSTALLATION

- a. Wrap splash guard around the brush deck base
- b. Place band clamp over the front band clamp stud
- c. Pull band clamp around brush deck base and place and clamp spring over rear band clamp stud
- d. Repeat process on opposite side of brush deck base



## MACHINE OPERATION

1. Connect machine connector to the battery connector



2. Turn on the brush motor switch. Battery charge indicator will illuminate indicating the charge level of the batteries. If the indicator is flashing the batteries need to be charged or a fault has occurred. Call technical service if problem persists after charging.
3. Turn on the brush motor switch. Please note that the scrubbing brushes will not rotate until the hand switch lever is engaged
4. Turn on the water solenoid valve switch
5. Turn on the vacuum motor switch



Battery charge indicator

## MACHINE OPERATION

5. Adjust the flow rate of the cleaning solution with lever. Moving the solution flow control lever downward increases the flow rate and raising the lever decreases the flow rate. There should be enough solution to wet the floor uniformly, but not so much that the water gets past the splash guard. Remember that the correct solution quantity depends on the type of floor, the dirt level and the scrubbing speed
6. Release and raise the brush base lift lever to lower the brush base
7. Lower the squeegee using the squeegee lift lever



### 8. SCRUBBING

The machine is equipped with pad assist propulsion. Depress the handle switch lever. The scrub brush will begin to rotate and solution will begin to flow. During the first few yards of operation, check that the quantity of the cleaning solution is sufficient to wet the floor and that the squeegee dries the floor surface



**WARNING!** Always lift the squeegee when moving backwards





## MACHINE OPERATION

### 10. OVER FILL PROTECTION

The machine is equipped with a float that stops the vacuum exhaust air flow when the recovery tank is full. Vacuum motor does not stop operating but the vacuum exhaust air flow rate is greatly reduced. When this occurs, empty the recovery tank by removing the drain plug on the drain hose and then empty the recovery tank



**WARNING!** Use gloves for protection from contact with dangerous solutions



## UPON COMPLETION OF MACHINE USE

After finishing your work and before any type of maintenance is done, it is necessary to do the following:

1. Close the water valve by raising the solution flow control lever
2. Raise the brush base by stepping down locking the brush base lift lever. To lock the lever move your foot to the right while the lever is pressed down
3. Lift the squeegee by raising the squeegee lift lever and locking it by moving the lever to the left



**WARNING!** The squeegee blades can be damaged if the squeegee is not raised during storage or transport

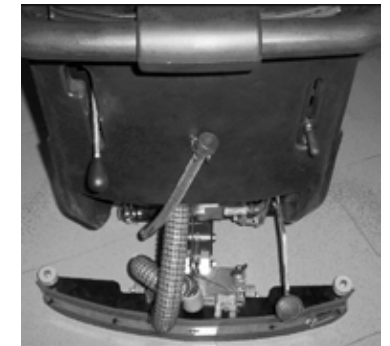

## UPON COMPLETION OF MACHINE USE

5. Switch off the water solenoid valve switch
6. Switch off the brush motor switch
7. Switch off the vacuum motor switch
8. Transport the machine to the location where the recovery tank should be emptied

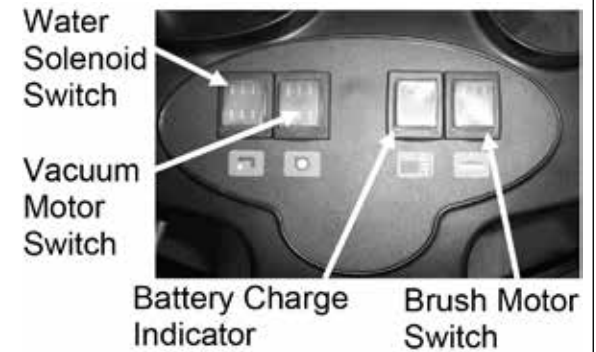

10. Remove the drain hose at the front of the recovery tank
11. Remove the drain plug and empty the recovery tank



**WARNING!** Use gloves for protection from contact with dangerous solutions

12. Remove the brush or pad driver and clean them with clear water



## DAILY MACHINE MAINTENANCE

### 1. CLEANING THE RECOVERY TANK

- a. Empty the recovery tank by removing the drain plug from the drain hose



**WARNING:** Use gloves for protection from contact with dangerous solution

- b. Lift the cover of the recovery tank
- c. Take off the vacuum cover by rotating it counter clockwise
- d. Remove the filter and its housing
- e. Rinse the tank with clean water



## DAILY MACHINE MAINTENANCE

### 2. CLEANING THE VACUUM FILTER

- a. Lift the cover
- b. Take off the vacuum cover by rotating it counter clockwise
- c. Remove the filter and its housing
- d. Use clear water to clean the walls and the bottom of the filter
- e. Remove the filter and its housing
- f. Wash all components thoroughly
- g. Reassemble repeating the above operations in reverse



### 3. CLEANING THE SQUEEGEE

To obtain the best drying results, keep the squeegee clean. To clean the squeegee it is necessary to:

- a. Remove the vacuum hose from the squeegee
- b. Lift locking latches. Remove the squeegee assembly by pulling rearward
- c. Clean the inside of the squeegee thoroughly
- d. Clean the squeegee blades thoroughly
- e. Reassemble

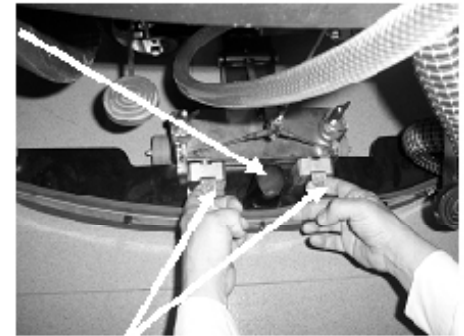

### 4. REPLACING THE SQUEEGEE BLADES

Check the squeegee blades for wear and if necessary, change them. To replace the squeegee blades:

- a. Remove the squeegee vacuum hose from its port
- b. Lift locking latches and pull squeegee assembly rearward
- c. Release the band clamps by lifting the band clamp latch
- d. Remove squeegee blades
- e. Rotate or replace the blades. Please note that the squeegee has 4 useable edges so you may be able to rotate squeegee blades
- f. To reassemble the squeegee, repeat the above operations in reverse



## DAILY MACHINE MAINTENANCE

### 5. BRUSH / PAD DRIVER REMOVAL

- a. Lift the brush base by depressing the foot level at the rear of the machine
- b. The photo shows the directions to rotate the brushes to unlock them from the auto scrubber. Clean the brushes with clear water



## WEEKLY MACHINE MAINTENANCE

### 1. CLEANING THE SQUEEGEE HOSE

To obtain the best drying results, keep the squeegee hose clean. To clean the squeegee hose it is necessary to:

- a. Take off the vacuum hose from its vacuum port on the squeegee
- b. Remove the other end of the vacuum hose from the recovery tank
- c. Wash the inner part of the hose with clean water
- d. Reassemble



**WARNING:** Do not wash the hose that goes from the vacuum motor to the vacuum cover



## WEEKLY MACHINE MAINTENANCE

### 2. SOLUTION TANK CLEANING

- a. Remove the fill cap from the solution tank
- b. Rinse with clear water
- c. Remove the solution tank drain hose and cap at rear of machine and empty the solution tank



**WARNING:** Use gloves for protection from contact with dangerous solution



### 3. IN-LINE FILTER CLEANING

- a. Drain solution tank
- b. Turn off solenoid valve
- c. Unscrew clear housing
- d. Remove screen and clean with clear water
- e. Reassemble



**WARNING:** Use gloves for protection from contact with dangerous solution

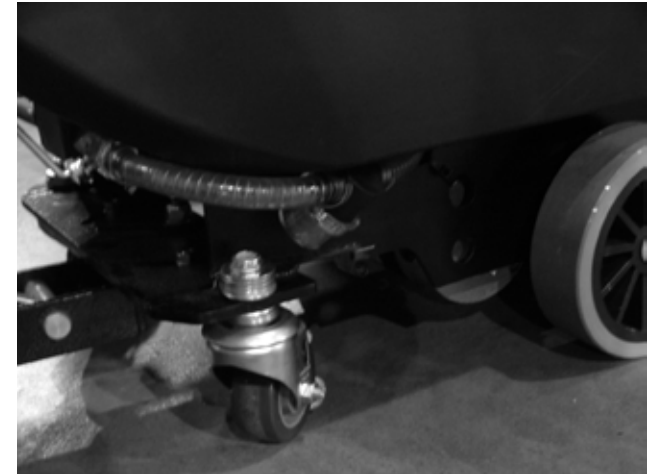
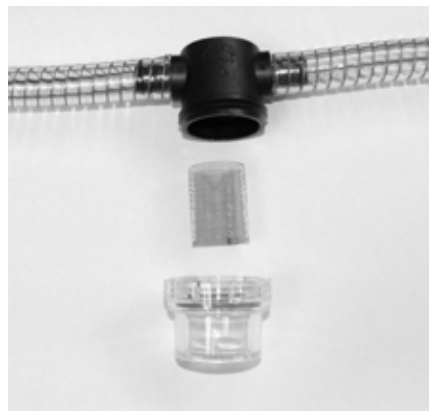

## WATER SOLENOID MAINTENANCE

In the event that the water solenoid begins to leak when turned off debris must be cleared at the valve seat. To gain access the water solenoid the scrub deck must be disassembled from the lifting arms. Remove the 3 bolts shown in the photo to release the scrub deck

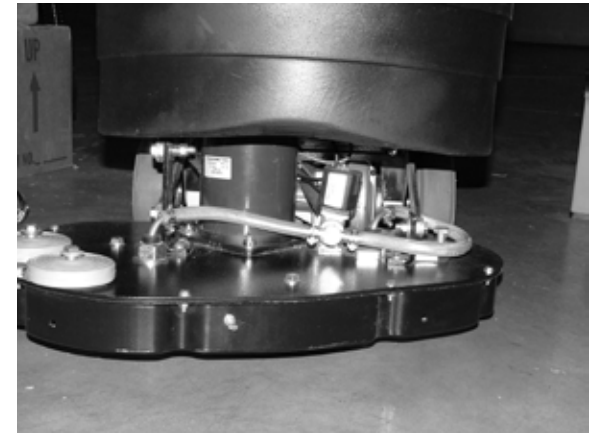

## TROUBLE SHOOTING GUIDE

### 1. INSUFFICIENT WATER TO THE BRUSHES

- a. Make sure the solution flow control valve is open
- b. Confirm that there is water in the solution tank
- c. Make sure solution dispensing tubes are not clogged or obstructed
- d. Make sure inline solution filter assembly is not clogged or obstructed

### 2. THE MACHINE DOES NOT CLEAN SATISFACTORILY

- a. Check the condition of the brushes or pads and replace them if necessary
- b. The brushes should be replaced when the bristles reach a length of 5/8 inches (15 mm)

### 3. THE SQUEEGEE DOES NOT DRY THE FLOOR WELL

- a. Check that the squeegee blades are clean
- b. Adjust the inclination of the squeegee
- c. Confirm that the vacuum hose is correctly fitted into its port in the recovery tank and free from obstructions
- d. Replace squeegee blades if worn
- e. Check that the vacuum motor switch is on
- f. Check the squeegee height adjustment (see "MACHINE PREPARATION" section)



## TROUBLE SHOOTING GUIDE

### 4. EXCESSIVE FOAM PRODUCTION

- a. Check that a low foaming detergent has been used. If required, add a small quantity of defoamer liquid to the recovery tank. More foam is generated when a floor is lightly soiled. Use less detergent if this is the case

# Z210 PAD ASSIST AUTO SCRUBBER - BRUSH DECK ASSEMBLY

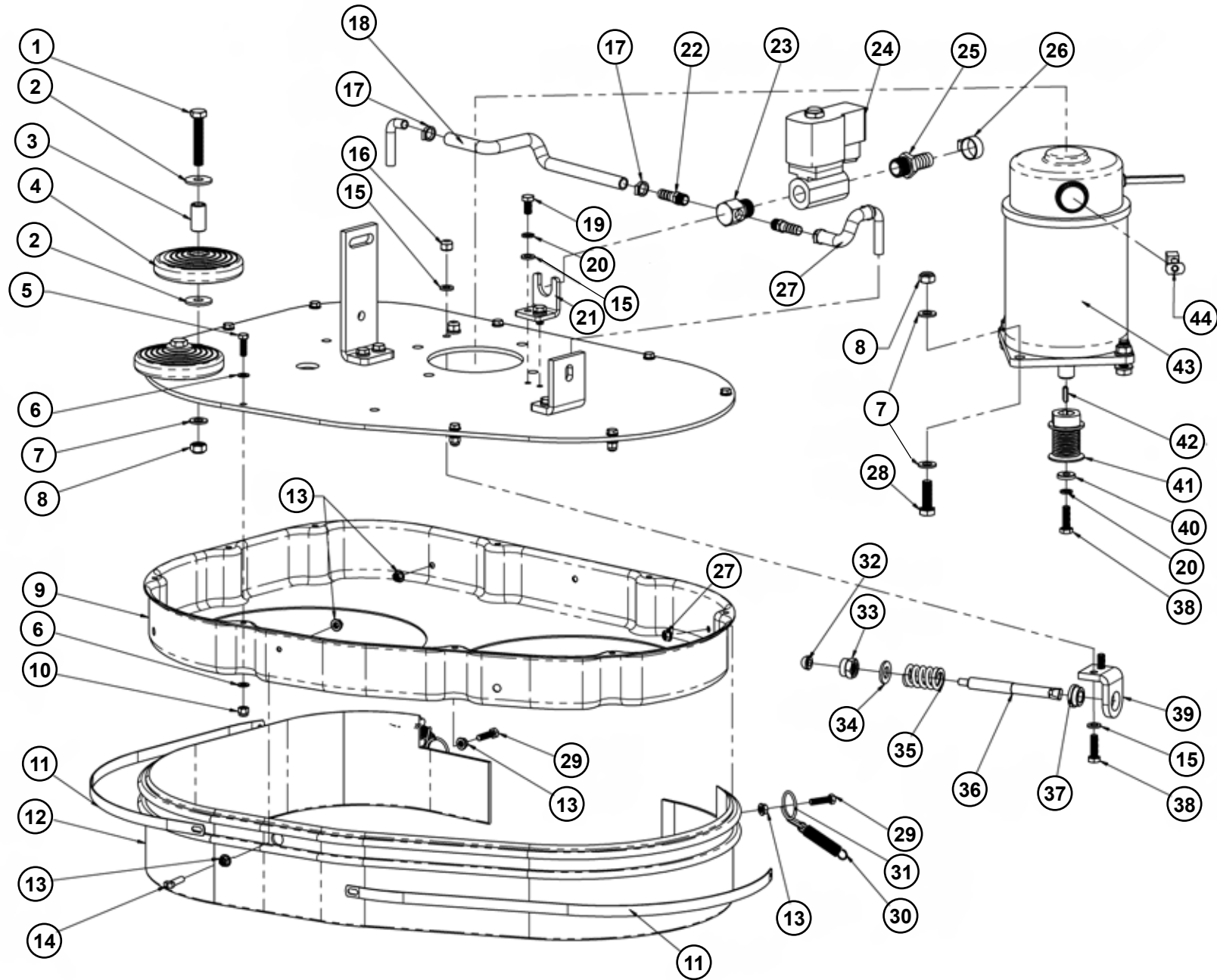



ITEM	PART #	DESCRIPTION	QTY	NOTE
1	964103	Hex Bolt-Full M8x45 Zinc	2	ZINC
2	980684	M8 Washers Flat L Zinc	2	ZINC
3	841102	Wheel Bushing	2	BRASS
4	849701	Wheel	2	
5	964335	Hex Bolt M5X16 Zinc	9	ZINC
6	980685	M5 Washer Flat Zinc	18	ZINC
7	980679	M8 Washer Flat Zinc	10	ZINC
8	924033	NyLoc Hex Nut M8 Zinc	6	ZINC
9	842303	Base Cover	1	EPOXY PAINT
10	924032	M5 Nyloc Hex Nut Zinc	9	ZINC
11	842006	Clamp - Band	2	SS
12	843601	Splash Guard - Blue	1	
	863605	Splash Guard - Orange	1	
	843610	Splash Guard - Black	1	
13	920658	Nut Flange M5 Zinc	6	ZINC
14	848402	Stud Screw	1	SS
15	980665	M6 Flat Washer Zinc	6	ZINC
16	920653	M6 Nyloc Hex Nut Zinc	2	ZINC
17	842004	Hose Clamp	4	SS
18	849010	Tubing	1	
19	964423	Hex Bolt M6X12 Zinc	2	ZINC
20	980672	M6 Lock Washer Zinc	3	ZINC
21	845604	Solenoid Valve Mount	1	ZINC

ITEM	PART #	DESCRIPTION	QTY	NOTE
22	843306	Fitting Barbed	2	
23	843324	Fitting	1	
24	849404	Solenoid Valve	1	
25	843323	Fitting Barbed	1	
26	842003	Hose Clamp	1	SS
27	849003	Tubing	1	
28	964239	Hex Bolt M8x25 Zinc	4	ZINC
29	964225	Hex Bolt M5X20 Zinc	2	ZINC
30	888336	Spring	2	ZINC
31	887350	Ring	2	ZINC
32	881151	Bushing	1	ZINC
33	924055	Lock Nut M10	1	ZINC
34	980064	M10 Washer Flat Zinc	1	ZINC
35	888342	Spring	1	ZINC
36	880550	Adjuster - Bolt	1	ZINC
37	881150	Bushing	1	
38	964116	Hex Bolt M6x20 Zinc	3	ZINC
39	840302	Brush Base Idler Arm Adjuster	1	EPOXY PAINT
40	849801	Thrust Washer	1	ZINC
41	846904	Pulley	1	ZINC
42	845003	Key - Motor Shaft	1	
43	845201	Brush Motor	1	
44	840904	Carbon Brush	2	

# Z210 PAD ASSIST AUTO SCRUBBER - BRUSH BASE ASSEMBLY

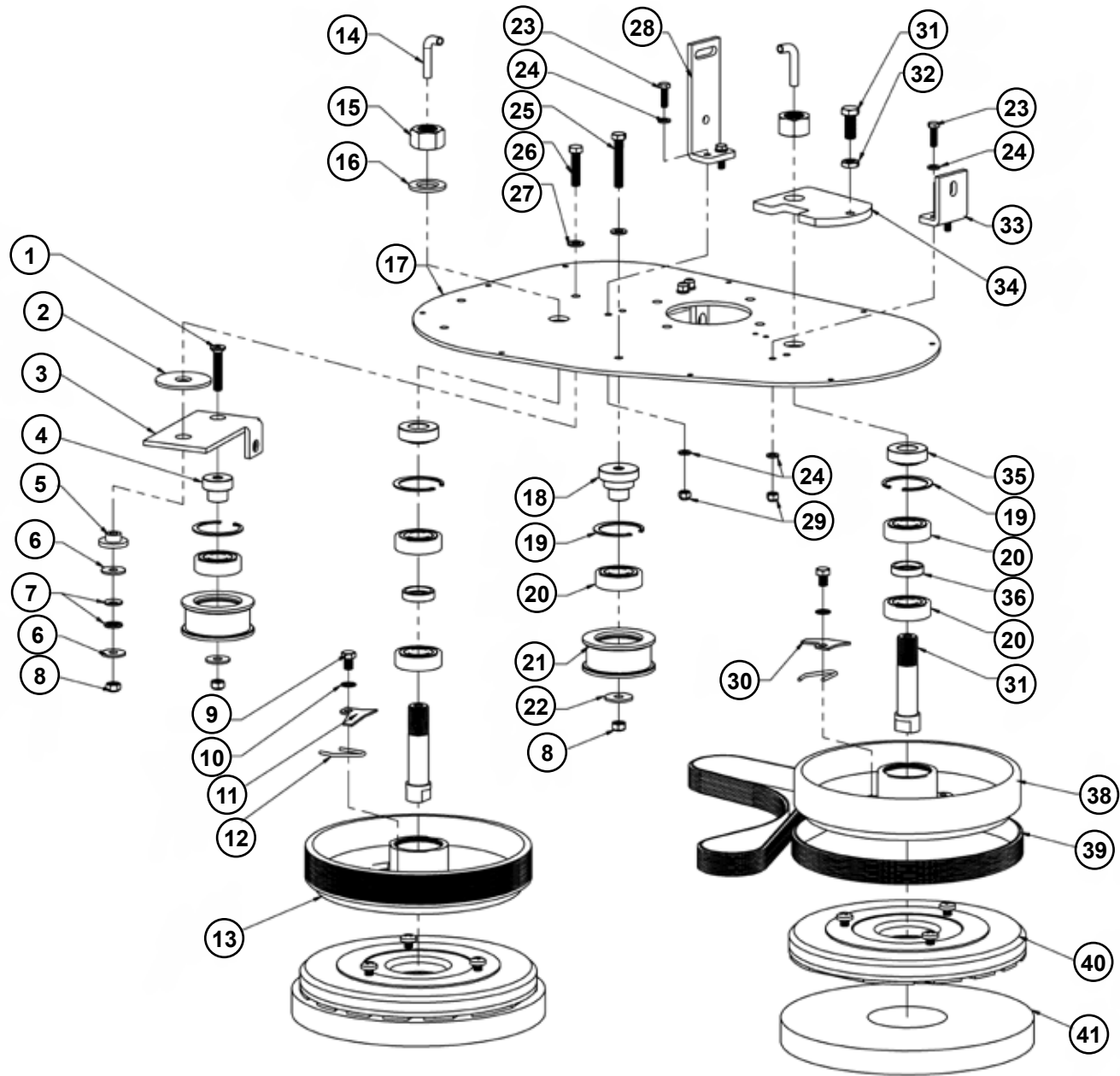

ITEM	PART #	DESCRIPTION	QTY	NOTE
1	964003	Screw Flat Head Torx Drive M8x45	1	ZINC
2	980668	Washer - Wide M16x56x3Thk	1	
3	840303	Idler Arm	1	EPOXY PAINT
4	844301	Bearing Hub	1	ZINC
5	841101	Bushing	1	
6	980684	M8 Washers Flat L Zinc	2	ZINC
7	980666	Spring Washer M8x18	2	
8	924033	NyLoc Hex Nut M8 Zinc	3	ZINC
9	964001	Hex Bolt M8x12	2	ZINC
10	980058	Washer Star Lock M8	2	ZINC
11	846402	Right Spring Retaining Plate	1	ZINC
12	848301	Brush Retaining Spring	2	ZINC
13	846903	Brush Clutch Pulley	1	
14	846001	Pipe	2	
15	920647	Hex Nut M20 Zinc	2	ZINC
16	980667	Washer M20x39 Flat Zinc	1	ZINC
17	841301	Brush Base Deck	1	EPOXY PAINT
18	844302	Bearing Hub	1	ZINC
19	847301	Reataining Ring 50 mm	4	
20	902033	Bearing	6	
21	846905	Idler Pulley	2	ZINC
22	980503	M8 Washer XL Flat Zinc	2	ZINC

ITEM	PART #	DESCRIPTION	QTY	NOTE
23	964116	Hex Bolt M6x20 Zinc	4	ZINC
24	980665	M6 Flat Washer Zinc	8	ZINC
25	964084	Hex Bolt-Full M8X50 Zinc	1	ZINC
26	964246	Hex Bolt M8x35 Zinc	1	ZINC
27	980679	M8 Washer Flat Zinc	2	ZINC
28	845102	Brush Base Dual Lift Link	1	EPOXY PAINT
29	920653	M6 Nyloc Hex Nut Zinc	4	ZINC
30	846401	Left Spring Retaining Plate	1	ZINC
31	964111	Hex Bolt M10X25 Zinc	1	ZINC
32	924068	Hex Nut M10 Thin Zinc	1	ZINC
33	845103	Brush Base Lift Link	1	EPOXY PAINT
34	846602	Plate	1	ZINC
35	848204	Spacer	2	ZINC
36	848201	Bearing Spacer	2	ZINC
37	847701	Brush Pulley Shaft	2	BLACK OXIDE
38	846902	Brush Clutch Pulley	1	
39	881352	210 Brush Drive Belt	1	
40	885950	Pad Driver 10 Inch	2	
41	885955	Pads, 10 Inch Black - Case of 5		
	885956	Pads, 10 Inch Green - Case of 5		
	885957	Pads, 10 Inch Red - Case of 5		
	885958	Pads, 10 Inch White - Case of 5		

# Z210 PAD ASSIST AUTO SCRUBBER - MAIN FRAME ASSEMBLY

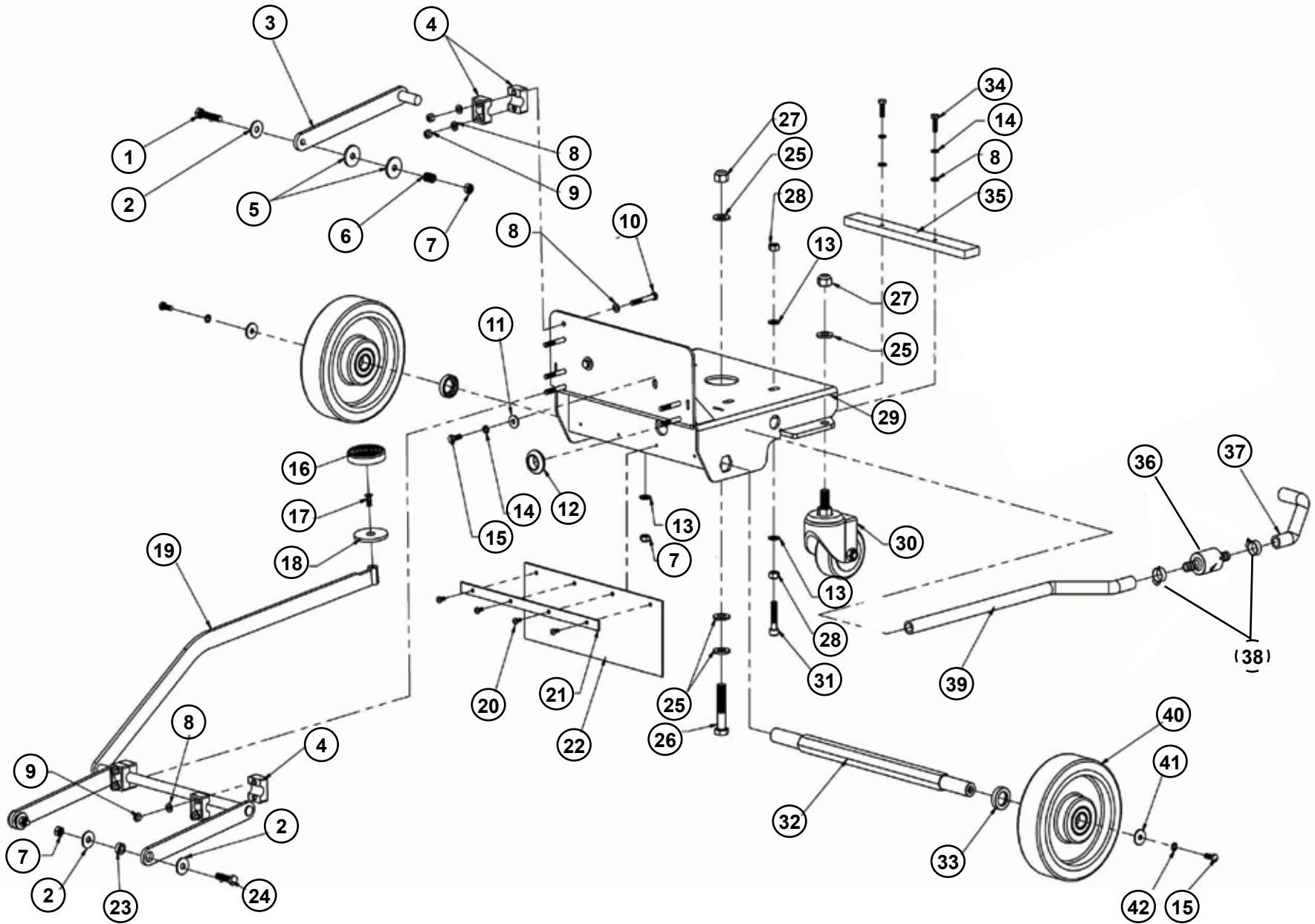

ITEM	PART #	DESCRIPTION	QTY	NOTE
1	964007	Hex Bolt M8X40 Zinc	1	ZINC
2	980684	M8 Washers Flat L Zinc	5	ZINC
3	840301	Brush Deck Lift Idler Arm	1	ZINC
4	847001	Brush Lift - Pivot Block	6	
5	980676	M8 Washer - Plastic	2	
6	848302	Spring	1	ZINC
7	924033	NyLoc Hex Nut M8 Zinc	7	ZINC
8	980665	M6 Flat Washer Zinc	14	ZINC
9	920653	M6 Nyloc Hex Nut Zinc	6	ZINC
10	964415	Hex Bolt M6x45 Zinc	6	ZINC
11	980671	M6 Washer Flat XL Zinc	2	ZINC
12	843801	Grommet	1	
13	980679	M8 Washer Flat Zinc	8	ZINC
14	980672	M6 Lock Washer Zinc	4	ZINC
15	964209	Hex Bolt M6X16 Zinc	4	ZINC
16	842306	Pedal Cover	1	
17	964400	Flat Head Soc Hex Screw M6x16 Zinc	1	ZINC
18	842701	Metal Disc	1	ZINC
19	840306	Brush Deck Lift Arm ASM	1	ZINC
20	964182	Screw M4x10 Pan Head Zinc	4	ZINC
21	842005	Clamp Bar	1	SS

ITEM	PART #	DESCRIPTION	QTY	NOTE
22	843602	Splash Guard	1	
23	841105	Bushing	2	BRASS
24	964083	Hex Bolt M8X30 Zinc	2	ZINC
25	980043	Washer Flat M12	5	ZINC
26	964230	Hex Bolt M12x65 Zinc	1	ZINC
27	920648	M12 Nyloc Hex Nut Zinc	3	ZINC
28	920649	Hex Nut M8 Zinc	4	ZINC
29	843202	Main Frame Weldment	1	EPOXY PAINT
30	849703	Caster	2	
31	964437	Screw - SHCS M8x40 Zinc	2	ZINC
32	847704	Wheel Shaft	1	ZINC
33	848211	Wheel Spacer	2	ZINC
34	964116	Hex Bolt M6x20 Zinc	2	ZINC
35	841330	Bar-Squeegee Stop	1	
36	843319	Inline Filter Assembly	1	
37	849001	Tubing	1	
38	842003	Hose Clamp	2	SS
39	849002	Tubing	1	
40	849704	Main Wheel	2	
41	980501	M6x22 OD Washer Flat Zinc	2	ZINC
42	980670	M6 External Lock Washer Zinc	2	ZINC

# Z210 PAD ASSIST AUTO SCRUBBER - SQUEEGEE FRAME ASSEMBLY

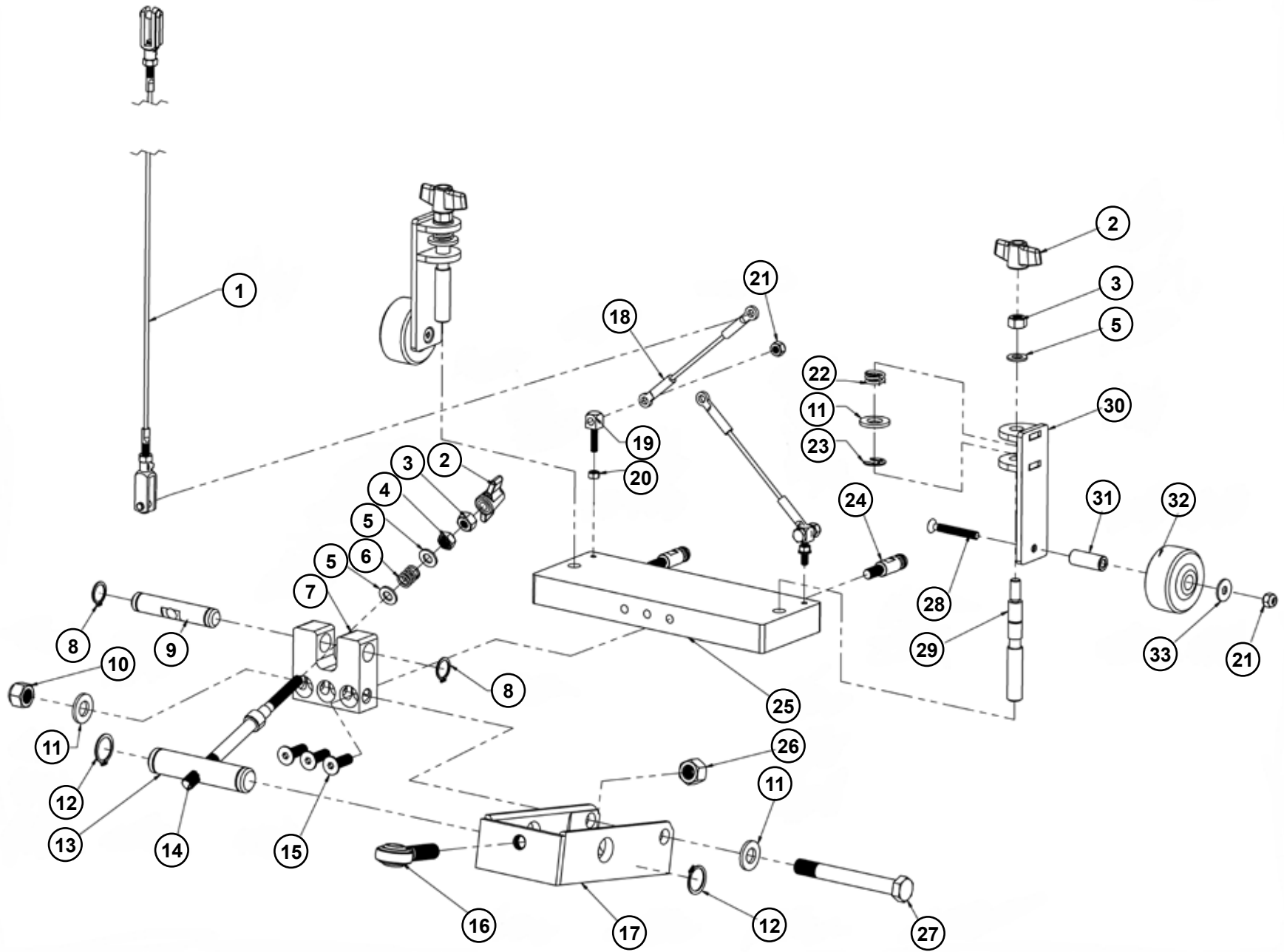

ITEM	PART #	DESCRIPTION	QTY	NOTE
1	842407	Squeegee Lift Cable	1	
2	845001	Adjustment Knob	3	
3	920649	Hex Nut M8 Zinc	3	ZINC
4	924033	NyLoc Hex Nut M8 Zinc	1	ZINC
5	980679	M8 Washer Flat Zinc	4	ZINC
6	848302	Spring	1	ZINC
7	845602	Squeegee Mount Base Pivot	1	ZINC
8	847303	Retaining Ring 15mm x 1.0mm THK	2	BLACK OXIDE
9	847703	Squeegee Adjuster Rear Shaft	1	ZINC
10	920648	M12 Nyloc Hex Nut Zinc	1	ZINC
11	980043	Washer Flat M12	4	ZINC
12	847302	Retaining Ring 20mm x 1.2mm THK	2	BLACK OXIDE
13	847702	Squeegee Adjuster Front Shaft	1	ZINC
14	840501	Squeegee Adjuster Bolt ASM	1	ZINC
15	964005	Flat Head Soc Hex Screw M8X25	3	ZINC
16	847403	Rod End Male M12 Zinc	1	ZINC
17	840304	Squeegee Link Arm Weldment	1	EPOXY PAINT

ITEM	PART #	DESCRIPTION	QTY	NOTE
18	842405	Squeegee Lift Cable	2	
19	964225	Hex Bolt M5X20 Zinc	2	ZINC
20	920615	Hex Nut M5 Zinc	2	ZINC
21	920653	M6 Nyloc Hex Nut Zinc	4	ZINC
22	848303	Spring - Squeegee Adjust	2	ZINC
23	887341	E-Ring 9 mm ID	2	BLACK OXIDE
24	846701	Squeegee Attachment Pin	2	ZINC
25	845601	Squeegee Mount Base	1	ZINC
26	920650	Hex Nut M12 Zinc	1	ZINC
27	964243	Hex Bolt M12x100 Lg Zinc	1	ZINC
28	964220	M6x45 Flat Hd Phil Zinc	2	ZINC
29	848401	Squeegee Wheel Adjusting Stud	2	SS
30	848501	Wheel Strut Upright	2	ZINC
31	841103	Wheel Bushing	2	
32	849709	Wheel 2"	2	
33	980671	M6 Washer Flat XL Zinc	2	ZINC

# Z210 PAD ASSIST AUTO SCRUBBER - SQUEEGEE ASSEMBLY

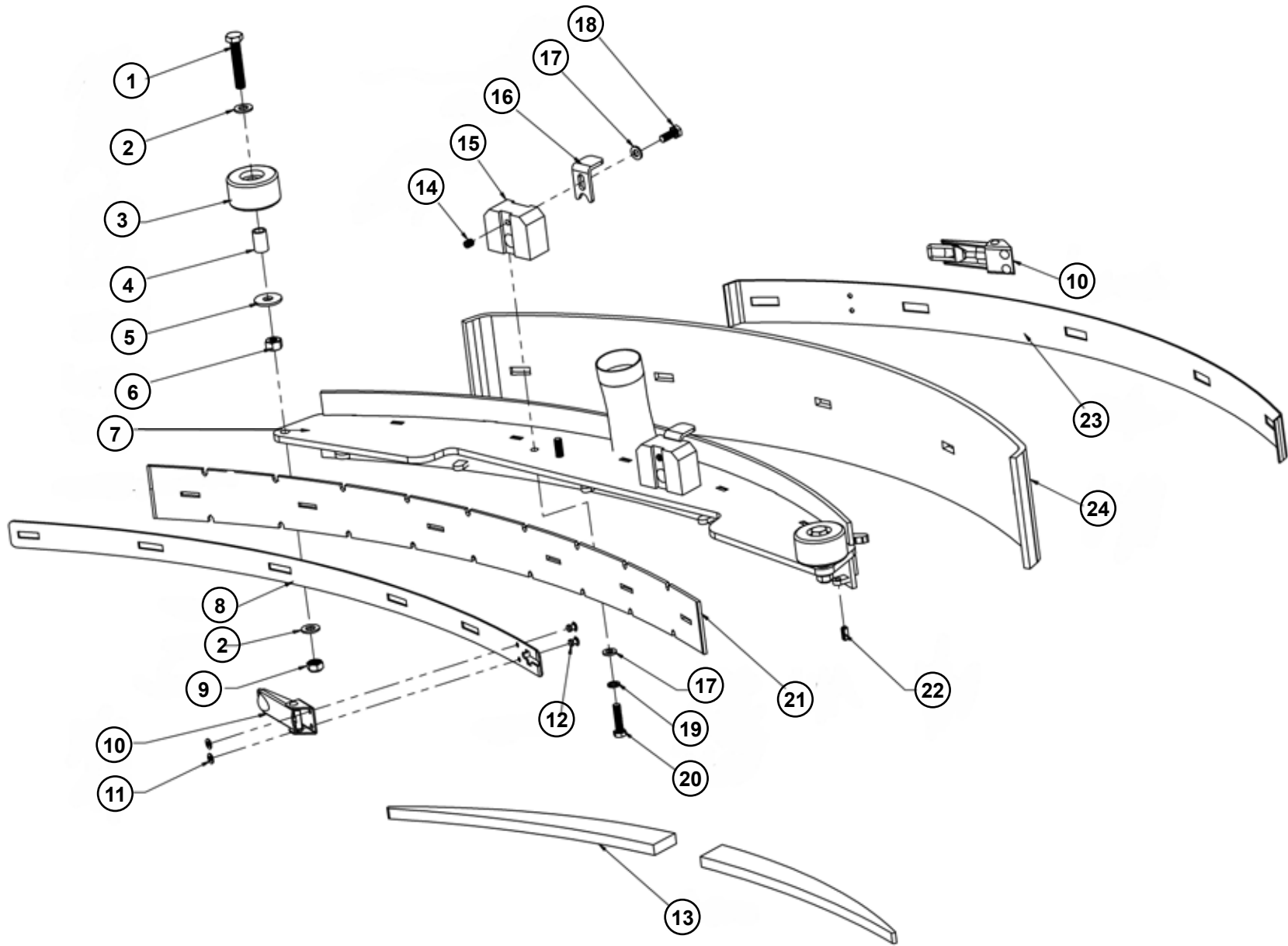



ITEM	PART #	DESCRIPTION	QTY	NOTE
1	964103	Hex Bolt-Full M8x45 Zinc	2	ZINC
2	980679	M8 Washer Flat Zinc	4	ZINC
3	889742	Wheel 45 Dia	2	
4	881145	Wheel Bushing	2	BRASS
5	980684	M8 Washers Flat L Zinc	2	ZINC
6	920649	Hex Nut M8 Zinc	2	ZINC
7	843201	Squeegee Frame Weldment	1	EPOXY PAINT
8	842002	Band Clamp-Front	1	SS
9	924033	NyLoc Hex Nut M8 Zinc	2	ZINC
10	845104	Latch ASM	2	ZINC
11	980033	Washer #6 Flat S/S	4	
12	W363D	Pop Rivet: #43 S/S	4	
13	843311	Filler - Squeegee	2	

ITEM	PART #	DESCRIPTION	QTY	NOTE
14	964004	Hex Set Screw M6X8	2	BLACK OXIDE
15	841304	Squeegee Attachment Block	2	ZINC
16	845105	Squeegee Attachment Block Latch	2	ZINC
17	980665	M6 Flat Washer Zinc	6	ZINC
18	964209	Hex Bolt M6X16 Zinc	2	ZINC
19	980672	M6 Lock Washer Zinc	4	ZINC
20	964232	Hex Bolt M6x25 Zinc	4	ZINC
21	840701	Squeegee Blade Front	1	
22	925009	Roll Pin M5.5x12 SS	1	SS
23	842001	Band Clamp-Rear	1	SS
24	840712	Squeegee Blade-Linatex	1	
	840702	Optional Squeegee Blade-Gum Rubber	1	

# Z210 PAD ASSIST AUTO SCRUBBER - SOLUTION TANK ASSEMBLY

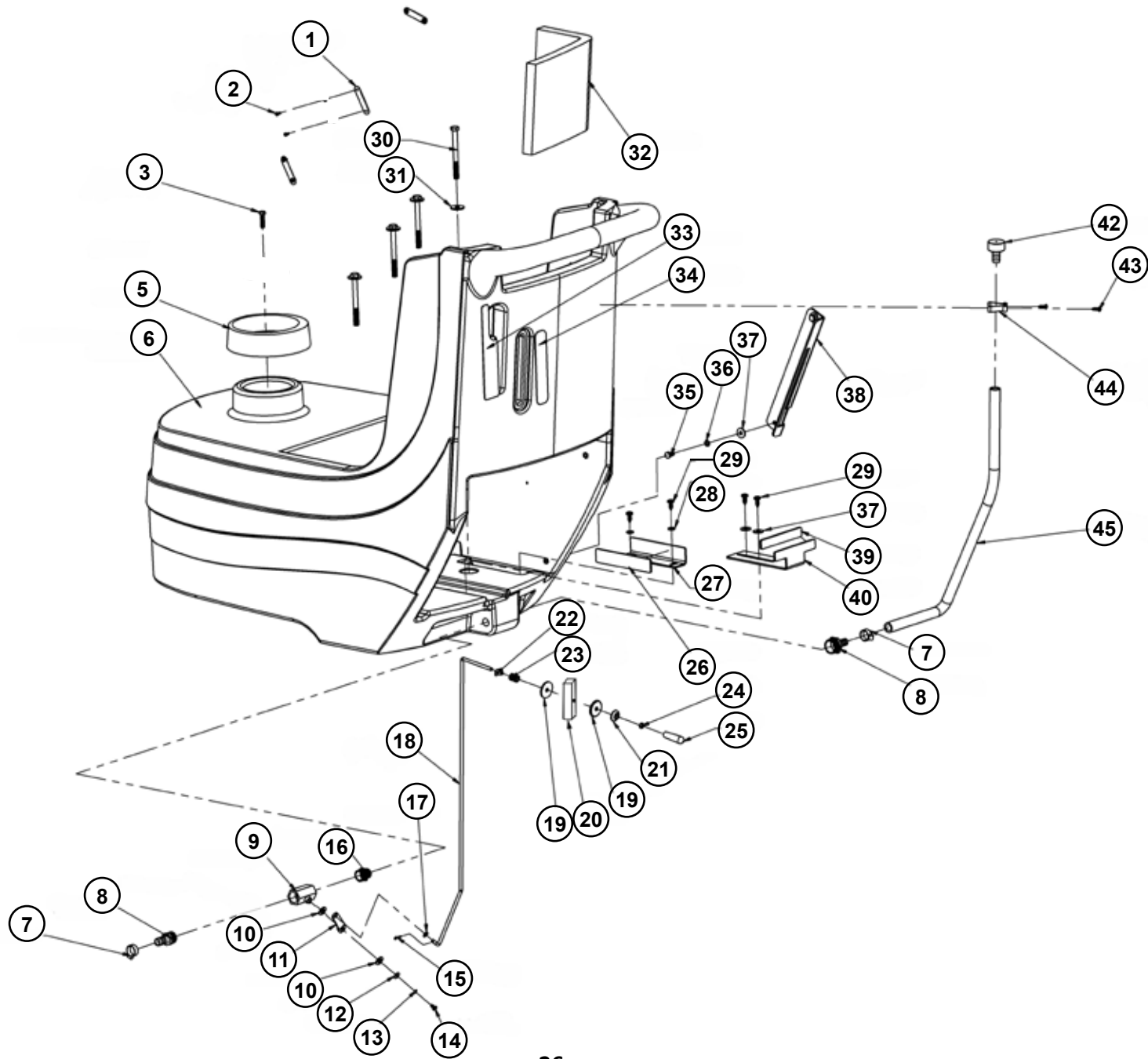

ITEM	PART #	DESCRIPTION	QTY	NOTE
1	846403	Plate Wire Retaining	3	
2	964228	M3x9.5 Pan Head Plastite Screw	6	ZINC
3	964398	Hex Bolt Full-THD M6x25 SS	1	SS
5	843406	Conical Tank Gasket	1	
6	848601	Solution Tank	1	
7	S453P	Hose Clamp	2	
8	223343	Fitting 1/2MPT x 1/2 Barb	2	
9	849402	Valve	1	
10	980679	M8 Washer Flat Zinc	2	ZINC
11	845107	Lever - Valve	1	ZINC
	849407	Valve w/Lever (Incl. #9, 10 & 11)	1	
12	980704	M5 Washer Flat SS	1	SS
13	980680	Lock Washer M4 Zinc	1	ZINC
14	964127	Screw M4X8 Pan Head Zinc	1	ZINC
15	A13507	Cotter Pin - 1/2 S/S	1	
16	843322	Fitting, Nipple 1/2NPT w/Hex	1	
17	980685	M5 Washer Flat Zinc	1	ZINC
18	847401	Rod - Connecting	1	ZINC
19	980504	M6x30 OD Washer Flat Plastic	2	
20	841310	Valve Limiting Bar	1	
21	980060	Plastic Washer M5	1	
22	924051	M5 Retaining Nut	1	ZINC

ITEM	PART #	DESCRIPTION	QTY	NOTE
23	848302	Spring	1	ZINC
24	920615	Hex Nut M5 Zinc	1	ZINC
25	885044	Knob	1	
26	843402	Side Battery Gasket	1	
27	841303	Side Battery Bracket	1	ZINC
28	980665	M6 Flat Washer Zinc	2	ZINC
29	964224	M5.5X16 Pan Head Plastite Screw	4	ZINC
30	964435	Hex Bolt M8x90 Zinc	4	ZINC
31	980684	M8 Washers Flat L Zinc	4	ZINC
32	842705	Sound Deadener	1	
33	845113	Squeegee Lift Label	1	
34	845111	Water Control Label	1	
35	964423	Hex Bolt M6X12 Zinc	2	ZINC
36	980672	M6 Lock Washer Zinc	2	ZINC
37	980671	M6 Washer Flat XL Zinc	4	ZINC
38	845106	Brush Deck Lift Latch	1	EPOXY PAINT
39	843401	Battery Plastic Gasket	1	
40	841302	Rear Battery Bracket	1	ZINC
42	886852	Cap	1	
43	964231	ST M4.2X12 Pan HD PL Zinc	2	ZINC
44	882440	Hook	1	SS
45	224130	Hose - 1/2" Drain (By Foot)	2	

# Z210 PAD ASSIST AUTO SCRUBBER - RECOVERY TANK ASSEMBLY

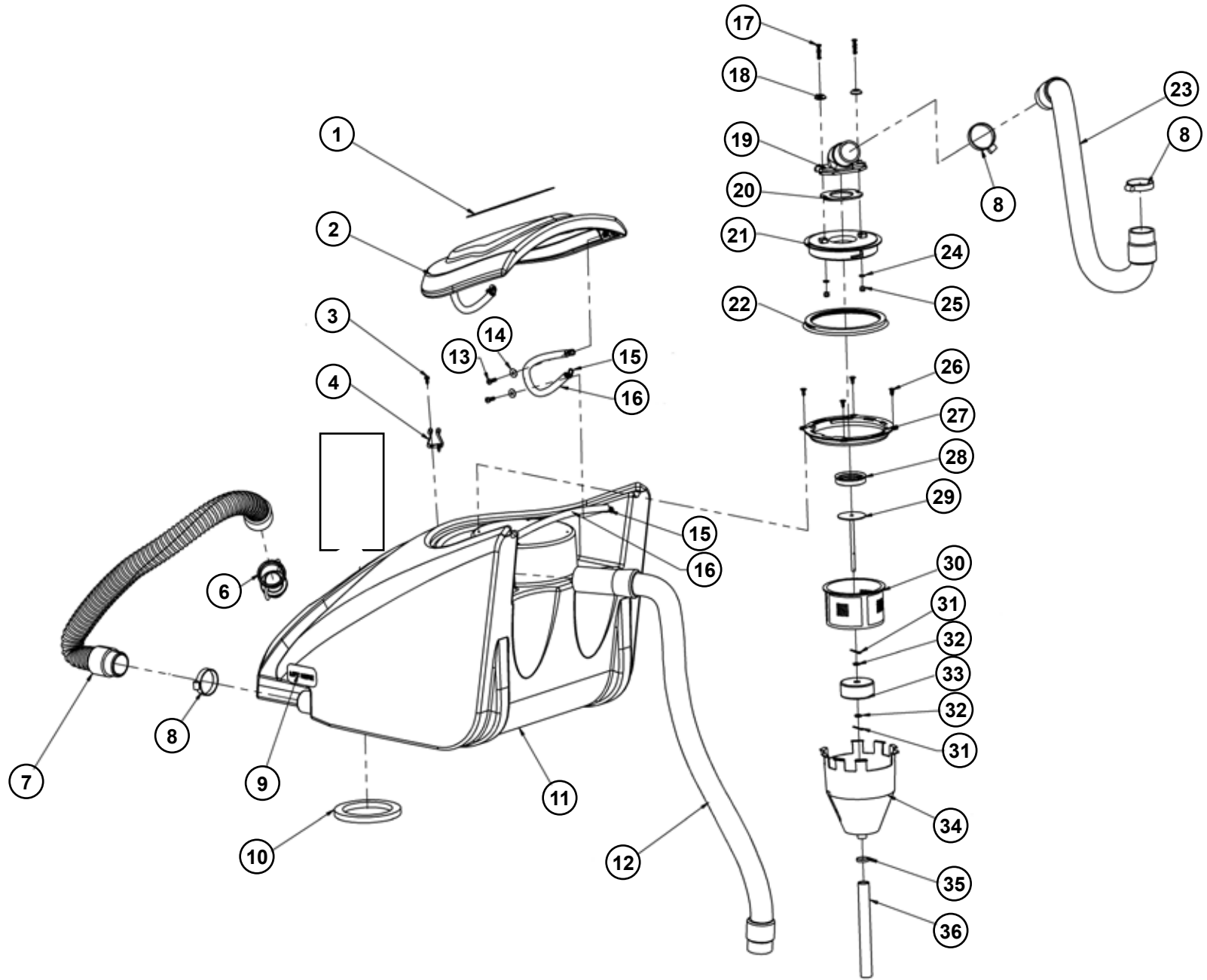

ITEM	PART #	DESCRIPTION	QTY	NOTE
1	845110	Recovery Tank Cover Label	1	
2	842304	Recovery Tank Cover	1	
3	964231	ST M4.2X12 Pan HD PL Zinc	2	ZINC
4	882440	Hook	1	SS
6	846801	Plug - Solution Tank Fill	1	
7	844103	Drain Hose	1	
8	S611A	Hose Clamp 45mm	3	SS
9	845131	Label For Lifting	2	
10	843405	Tank Gasket	1	
11	848608	Recovery Tank-Blue	1	
	848602	Recovery Tank-Gray	1	
12	844102	Squeegee Vacuum Hose	1	
13	964438	Screw M5x16 Pan Head Zinc	4	ZINC
14	980502	M5 x 15OD Flat Washer Zinc	4	ZINC
15	842403	Chain	3	SS
16	848101	Sleeve	3	
17	964105	Oval HD PHL Screw M5x25 SS	2	SS
18	980060	Plastic Washer M5	2	

ITEM	PART #	DESCRIPTION	QTY	NOTE
19	882442	Vacuum Outlet Port	1	
20	883446	Gasket	1	
21	886841	Filter Cover	1	
22	883441	Gasket	1	
23	844101	Recovery Tank Vacuum Hose	1	
24	980704	M5 Washer Flat SS	2	SS
25	924045	M5 Nyloc Hex Nut Stainless	2	SS
26	964063	FLHD Screw Ph Drive SS 4.2x13	4	SS
27	847304	Ring - Filter Holder	1	
28	883442	Gasket	1	
29	887440	Float Rod	1	SS
30	883343	Filter Basket	1	
31	925603	Cotter Pin M2x20	2	SS
32	980675	M6 Flat Washer Stainless	2	SS
33	883344	Float	1	
34	888551	Splash Protector	1	
35	S453P	Hose Clamp	1	
36	849004	Tubing	1	

# Z210 PAD ASSIST AUTO SCRUBBER - VACUUM ASSEMBLY

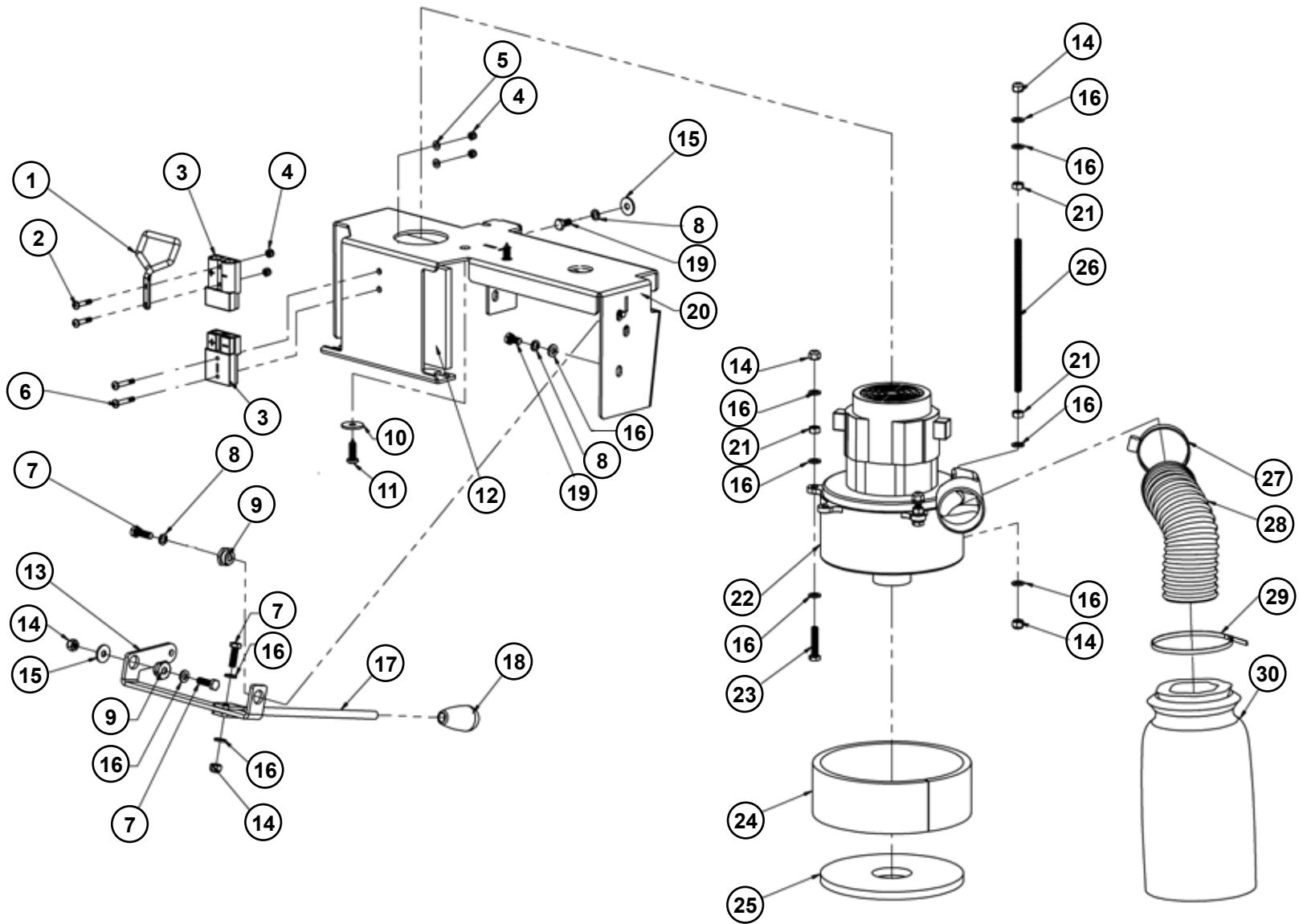

ITEM	PART #	DESCRIPTION	QTY	NOTE
1	843901	Connector Handle	1	
2	964422	Screw M4x20 Pan HD PL Zinc	2	ZINC
3	911186	Plug - Charge	2	
4	920033	M4 Hexagon Lock Nut	4	ZINC
5	980681	Washer M4 Flat Zinc	2	ZINC
6	964421	Screw M4x25 Pan HD PL Zinc	2	ZINC
7	964116	Hex Bolt M6x20 Zinc	3	ZINC
8	980672	M6 Lock Washer Zinc	6	ZINC
9	841104	Bushing	2	BRASS
10	980501	M6x22 OD Washer Flat Zinc	2	ZINC
11	962332	ST M6.3X22 Pan Head Zinc	2	ZINC
12	842704	Sound Deadener	1	
13	841312	Bracket, Lift, Squeegee	1	
14	920653	M6 Nyloc Hex Nut Zinc	6	ZINC
15	980671	M6 Washer Flat XL Zinc	2	ZINC
16	980665	M6 Flat Washer Zinc	17	ZINC
17	840305	Lever Arm Weldment	1	ZINC

ITEM	PART #	DESCRIPTION	QTY	NOTE
18	845002	Lever Arm Knob	1	ZINC
19	964423	Hex Bolt M6X12 Zinc	5	ZINC
20	840805	Bracket-Weldment	1	EPOXY PAINT
21	924063	Hex Nut M6 Zinc	4	ZINC
22	845202	24VDC Vacuum Motor - SIX	1	
23	964176	Hex Bolt M6X30 Zinc	2	ZINC
24	842702	Vacuum Motor Sound Deadener	1	
25	842703	Vacuum Motor Sound Deadener	1	
26	847405	Rod - Connecting	1	ZINC
27	842014	Hose Clamp 50mm	1	SS
28	844104	Vacuum Exhaust Hose	1	
29	911531	Hose Clamp	1	
30	845603	Muffler	1	
Not Shown - Support Plate Assm for Muffler:				
	74400019	Support Plate	1	
	911104	Cable Tie 14.5 Long	1	
	964228	M3x9.5 Pan Head Plastite Screw	2	

# Z210 PAD ASSIST AUTO SCRUBBER - SWITCH BOX ASSEMBLY

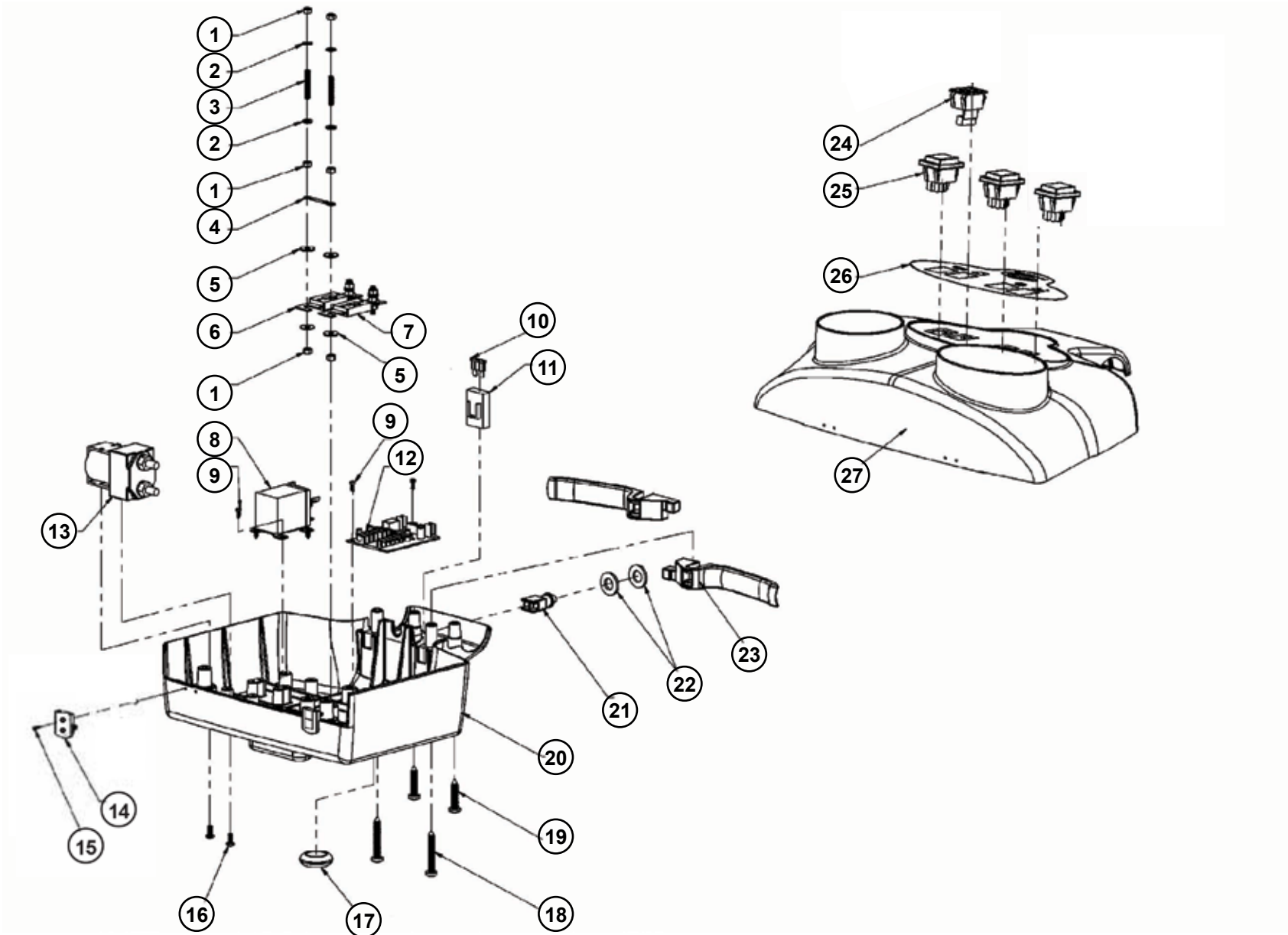



ITEM	PART #	DESCRIPTION	QTY	NOTE
1	920615	Hex Nut M5 Zinc	12	ZINC
2	980685	M5 Washer Flat Zinc	8	ZINC
3	964237	Set Screw Socket M5X30 Zinc	4	ZINC
4	911440	Jumper Wire	1	
5	980502	M5 x 15OD Flat Washer Zinc	8	ZINC
6	911443	Fuse 50Amp	1	
7	911424	Fuse 30Amp	1	
8	847501	Traction & Vacuum Motor Relay	1	
9	964228	M3x9.5 Pan Head Plastite Screw	6	ZINC
10	911431	Fuse 3Amp	1	
11	844001	Fuse Holder	1	
12	911308	Battery Check Card	1	
13	911419	Brush Motor Relay	1	
14	846406	Strap-Wire Retaining	2	
15	964228	M3x9.5 Pan Head Plastite Screw	4	ZINC
16	964182	Screw M4x10 Pan Head Zinc	2	ZINC
17	843801	Grommet	1	
18	964238	Plastite Screw M6x45 Pan HD PL Zinc	2	ZINC
19	964229	M6.0x32 Pan Head Plastite Screw	2	ZINC
20	842302	Cover Lower Switch Box	1	
21	911427	Microswitch	1	
22	980043	Washer Flat M12	2	ZINC
23	845101	Scrubber Lever - Switch Box	2	
24	911421	Battery Charge Numeric Indicator	1	
25	911172	Rocker Switch Green	3	
26	845115	Switch Box label	1	
27	842301	Cover Upper Switch Box	1	

# Z210 PAD ASSIST AUTO SCRUBBER - WIRING DIAGRAM

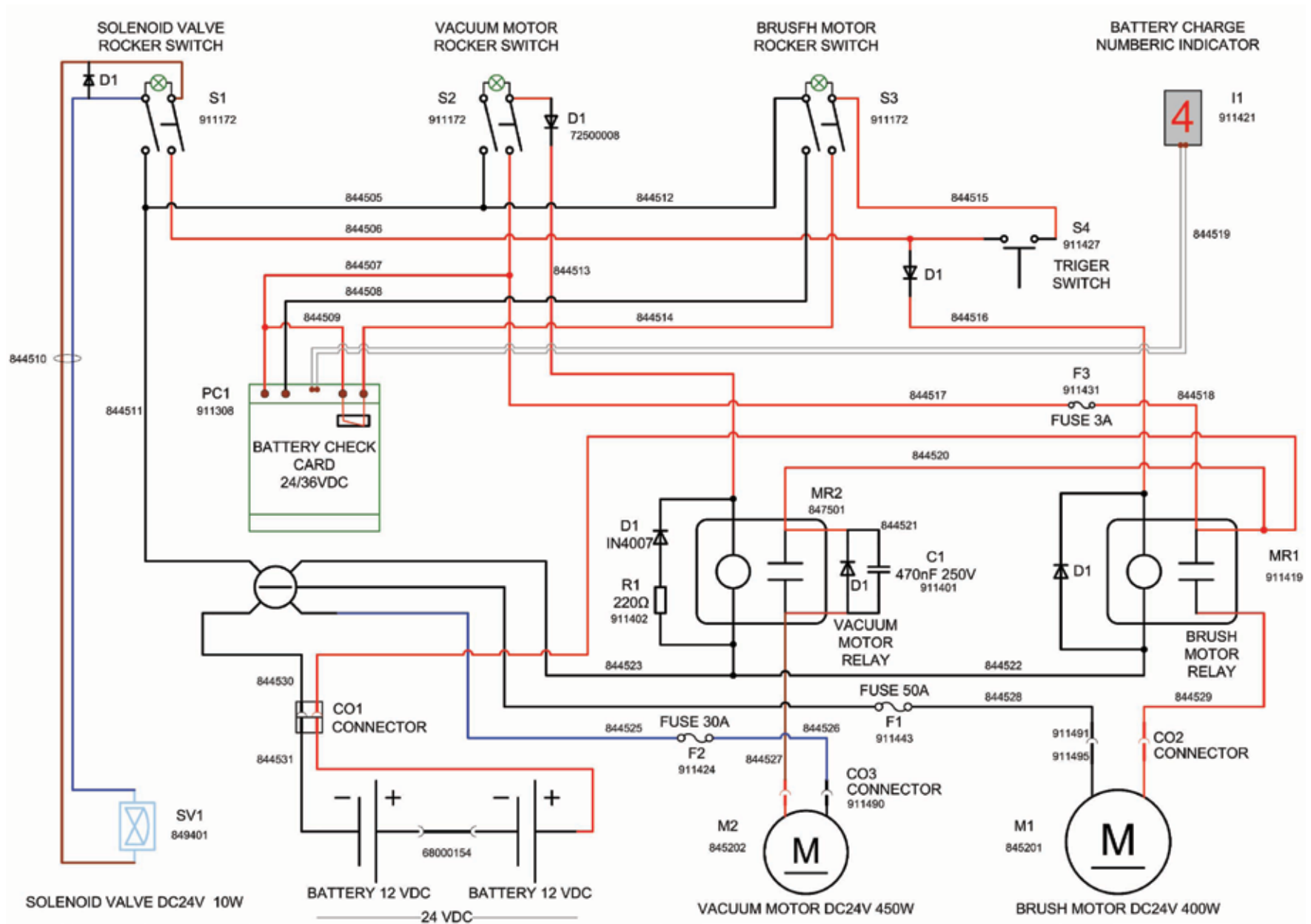

**WARRANTY POLICY**  
**AUTO SCRUBBER, Z210 PAD ASSIST**

The **Pacific** Z210 pad assist auto scrubber has been manufactured, tested and inspected in accordance with specific engineering requirements. This machine is **WARRANTED** to be free from defects in workmanship and materials for periods as follows from the date of purchase.

Ten (10) Years Parts, One (1) Year Labor – Polyethylene Components  
Five (5) Years Parts, One (1) Year Labor – Main Frame

Two (2) Years Parts, One (1) Year Labor – Brush Drive Motors  
One (1) Year Parts & Labor – All other components unless excluded below

Travel time for warranty repair is authorized for a period of ninety (90) days following the date of sale to the end user, with a maximum of three (3) hours per claim.

This warranty extends to the original user/purchaser and only when used, operated and maintained in accordance with **Pacific** Operating and Maintenance instructions.

This warranty does not apply to certain wear parts and accessories of the machine such as carbon motor brushes, floor brushes or pad drivers, belts, hoses, squeegee blades, etc., nor does it apply to damage or failure caused by improper use, abuse or neglect. Warranty credit or replacement of return parts including motors, switches, etc., is subject to incoming inspection of those items.

To secure repair under this warranty, the following procedure should be taken:

1. After the expiration of the ninety (90) day travel time warranty period, the customer is responsible for warranty travel payment or the inoperative machine or warranted parts must be delivered to the authorized dealer with shipping and delivery charges prepaid. If unable to locate the Dealer, you may contact **Pacific** at the address listed herein for the location of the nearest **Pacific** repair center or agent or for other instructions pertaining to your warranty difficulty.
2. Upon compliance with the above warranty procedure, all warranted repairs will be completed at no additional charge or cost to the user.
3. Only **Pacific** or its authorized dealers and agents may make no charge warranty repairs on this product. All others do so at their own risk.

This warranty limits **Pacific** liability to the repair of the product and/or warranted parts replacement and does not include incidental or consequential damages arising from the use of a **Pacific** machine whether defective or not.

**BATTERY WARRANTY**

In addition to the terms above, any original equipment **Pacific** Battery which becomes unserviceable under normal use within a period of ninety (90) days from date of sale to the original user will be repaired or replaced with one of equal specification at our option, F.O.B. any authorized Pacific or Service Branch, with no charge to user, except transportation costs. After the expiration of the above ninety (90) day period, any battery which fails under normal use will be adjusted to the original user with a new battery of equal specification on a twelve (12) month pro rata basis from the date of purchase. Adjustment will be determined using the then current list price, plus transportation costs. Warranty is rendered null and void if battery maintenance is not performed regularly.

This warranty is in lieu of all other expressed or implied warranties and is extended to the original purchaser/user.



**PACIFIC™**  
FLOORCARE

PURPOSE BUILT.™

2259 S. SHERIDAN DRIVE  
MUSKEGON, MICHIGAN 49442-6252  
800-968-1332

FAX 800-863-9536