

PARTS DIAGRAM

DISK FLOOR MACHINE

TOOLS REQUIRED

7/16" SOCKET WRENCH OR OPEN END WRENCH

1/2" SOCKET WRENCHES OR OPEN END WRENCHES – 2 REQUIRED

5/8" OPEN END WRENCH

1" OPEN END WRENCH

ITEM	SOLUTION TANK KIT	545007	QTY
1	TANK ASSY FM	548601	1
2	FITTING STR .25 FPT .25 BARB BRASS	533301	1
3	TUBING 1/4" - 11"	544105	1
4	FITTING ELBOW .25NPT .25 BARB NYL	533302	1
5	FITTING BULKEAD	T4056	1
6	PLATE ADAPTER TANK	546102	2
7	CLAMP U-SHAPED WITH RUBBER	542002	2
8	SCREW, HEX, 5/16-18X1.75,SS	962270	4
9	WASHER FLAT .31 ZINC	980007	4
10	NUT, NYLOCK, 5/16-18, ZINC	920012	4
11	NUT, NYLOCK, 1/4-20, ZINC	920011	4

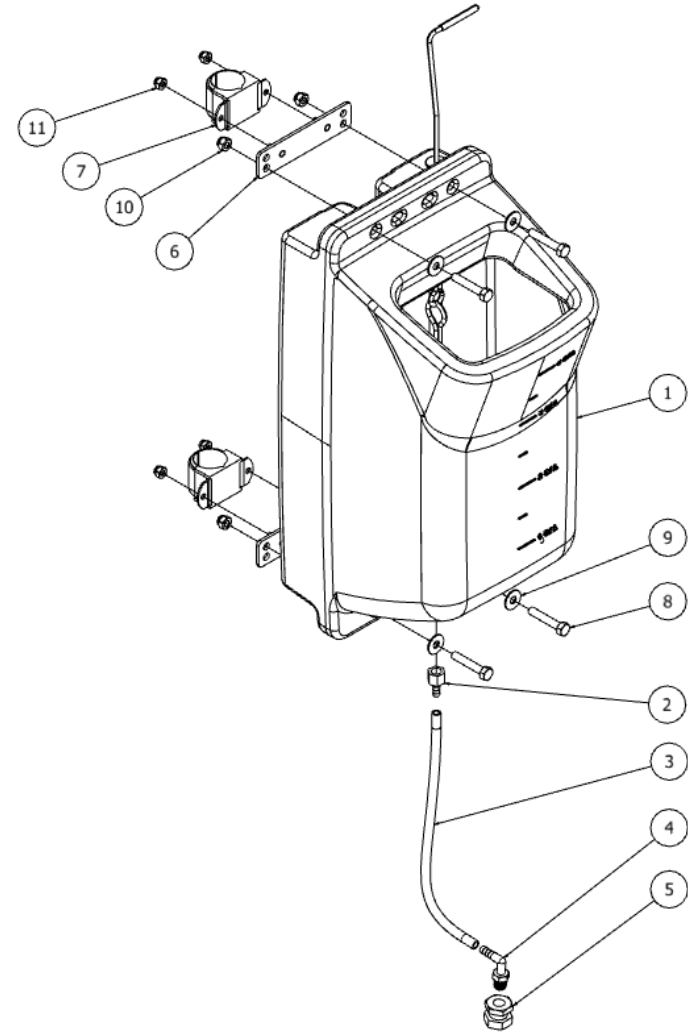

PACIFICTM
FLOORCARE

INSTALLATION INSTRUCTIONS

DISK FLOOR MACHINE

- | STEP | INSTRUCTIONS |
|------|--|
| 1 | Use hardware (items 8, 9 & 10) to attached both brackets (item 6) to the tank (item 1). |
| 2 | Place both clamps (item 7) on the handle of the machine. |
| 3 | Use nuts (item 11) to attach the tank sub-assembly to the clamps. |
| 4 | Ensure the tank is positioned to allow the machine handle to rest in it's fully upright position. |
| 5 | Assemble the bulkhead fitting (item 5) to the hole provided in the base of the machine. |
| 6 | Assemble the tube and fitting (items 2 & 3) to the bottom fitting on the tank.
Note: some items may need to be removed from the tank. |
| 7 | Connect the tube to the elbow fitting (item 4). |

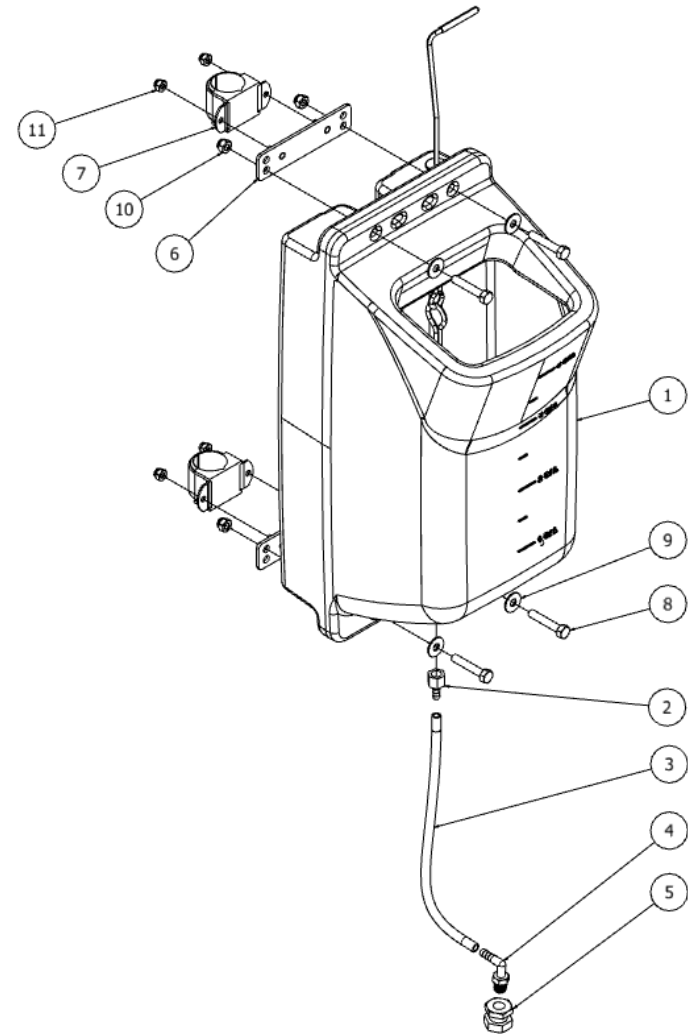

PARTS DIAGRAM

ORBITAL FLOOR MACHINE

TOOLS REQUIRED

7/16" SOCKET WRENCH OR OPEN END WRENCH

1/2" SOCKET WRENCHES OR OPEN END WRENCHES – 2 REQUIRED

5/8" OPEN END WRENCH

3/4" DEEP WELL SOCKET WRENCH

ITEM	SOLUTION TANK KIT	545005	QTY
1	TANK		1
2	FITTING STR .25 FPT .25 BARB BRASS	533301	1
3	HOSE REPL 1/4" DIA X 9" LONG	544104	1
4	FITTING, TEE, .25INCH	873301	1
5	HOSE REPL 1/4" DIA X 15" LONG	544106	1
6	HOSE REPL 1/4" DIA X 11" LONG	544105	1
7	FITTING STRAIGHT .25NPT .25BARB	543301	2
8	NUT .25NPT PLASTIC	920699	2
9	PLATE ADAPTER TANK	546102	2
10	CLAMP U-SHAPED WITH RUBBER	542002	2
11	SCREW, HEX, 5/16-18X1.75,SS	962270	4
12	WASHER FLAT .31 ZINC	980007	4
13	NUT, NYLOCK, 5/16-18, ZINC	920012	4
14	NUT, NYLOCK, 1/4-20, ZINC	920011	4

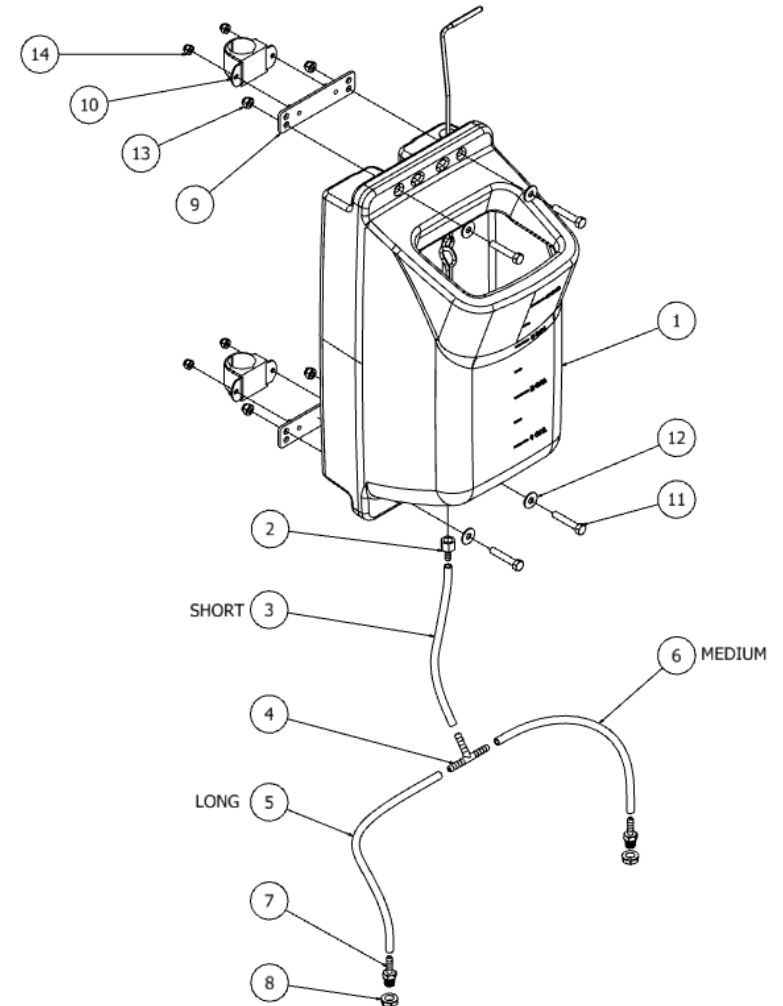

PACIFICTM
FLOOR CARE

INSTALLATION INSTRUCTIONS

ORBITAL FLOOR MACHINE

STEP INSTRUCTIONS

- 1 Use hardware (items 11, 12 & 13) to attached both brackets (item 9) to the tank (item 1).
- 2 Place both clamps (item 10) on the handle of the machine.
- 3 Use nuts (item 14) to attach the tank sub-assembly to the handle of the machine.
- 4 Ensure the tank is positioned to allow the machine handle to rest in it's fully upright position.
- 5 Assemble fitting and plastic nut (items 7 & 8) to the holes provided in the steel base of the machine.
- 6 Assemble tubes and fittings (items 2 through 6) to the bottom fitting on the tank.
Note: some items may need to be removed from the tank.
- 7 Connect hoses (items 5 & 6) to the straight fittings (item 7) and the tee fitting (item 4).

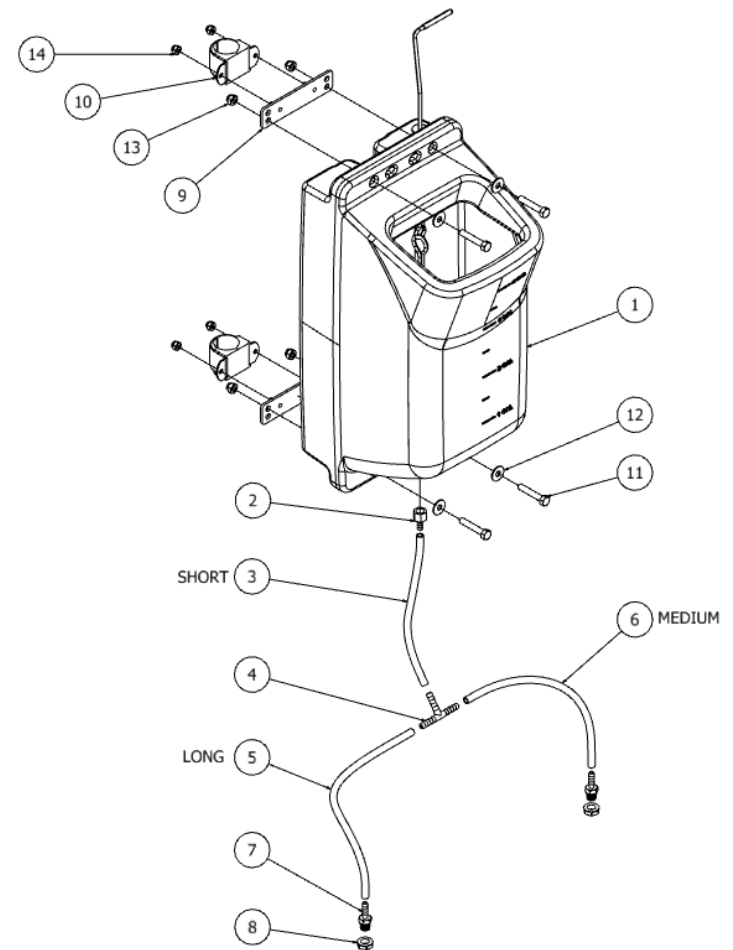

PACIFICTM
FLOORCARE