



**PACIFIC**<sup>®</sup>  
F L O O R C A R E

Powered by  
**ORBOT**<sup>®</sup>



## **MSE-19 ORB OPERATING MANUAL**

**MSE-19 ORB MACHINE DATA**

Model:	MSE-19 ORB
Serial:	_____
Date of Purchase:	_____
Dealer:	_____
Address:	_____
Phone Number:	_____
Sales Representative:	_____

<b>Machine Data</b>	<b>2</b>
<b>How to Use This Manual</b>	<b>4</b>
<b>Safety - Important Instructions</b>	<b>5 - 7</b>
<b>Technical Details</b>	<b>8</b>
<b>Operation</b>	<b>9 - 16</b>
Unpacking and Initial Operations	<b>9</b>
Pre-Run Inspection	
Power Cable Connection	
Spray System Preparation	
Spray Jets	<b>10</b>
Adjusting Height	
Process of Cleaning	
End of Application	<b>11</b>
Storage	
Lifting and Carrying	
Weight Kit Installation	<b>12</b>
Brush Installation	
Attaching and Removing the Driver Plates	<b>13</b>
Accessories and Applications	
Multi-Floor Velcro Driver Plate	<b>14</b>
AgiClean Pad	
SuperZorb Pad	
UltraLift Pad	<b>15</b>
AkwaStrip Pad	
Multi-Purpose Scrub Brush	<b>16</b>
<b>Operation/Maintenance</b> (Application on Different Floors)	<b>17</b>
Carpet Cleaning, Cleaning Hard Floors	
Cleaning the Machine	
Changing the Driver Grip Face	
<b>Part Diagrams and Part Lists</b>	<b>18 - 26</b>
<b>Wiring Diagram</b>	<b>27</b>

# HOW TO USE THIS MANUAL

This manual contains the following sections:

- How to Use This Manual
- Safety
- Operations
- Maintenance
- Parts List

The HOW TO USE THIS MANUAL section will tell you how to find important information for ordering correct repair parts.

Parts may be ordered from authorized dealers. When placing an order for parts, the machine model and machine serial number are important. Refer to the MACHINE DATA box which is filled out during the installation of your machine. The MACHINE DATA box is located on the inside of the front cover of this manual.

The model and serial number of your machine is located on the left side of the handle, from the operators perspective.

The SAFETY section contains important information regarding hazardous or unsafe practices of the machine. Levels of hazards are identified that could result in product damage, personal injury, or severe injury resulting in death.

The OPERATIONS section is to familiarize the operator with the operation and function of the machine.

The MAINTENANCE section contains preventive maintenance to keep the machine and its components in good working condition. They are listed in this general order:

- Storage
- Maintenance
- Troubleshooting

The PARTS LIST section contains assembled parts illustrations and corresponding parts list. The parts lists include a number of columns of information:

- REF – column refers to the reference number on the parts illustration.
- PART NO. – column lists the part number for the part.
- PRV NO. – reference number.
- QTY – column lists the quantity of the part used in that area of the machine.
- DESCRIPTION – column is a brief description of the part.
- SERIAL NO. FROM – If this column has an (\*) and a Reference number, see the SERIAL NUMBERS page in the back of your manual. If column has two asterisk (\*\*), call manufacturer for serial number. The serial number indicates the first machine the part number is applicable to. The main illustration shows the most current design of the machine. When a boxed illustration is shown, it displays the older design.
- NOTES – column for information not noted by the other columns.

**NOTE:** If a service or option kit is installed on your machine, be sure to keep the KIT INSTRUCTIONS which came with the kit. It contains replacement parts numbers needed for ordering future parts.

**NOTE:** The manual part number is located on the lower left corner of the front cover.

## IMPORTANT SAFETY INSTRUCTIONS

When using this machine, basic precautions must always be followed, including the following:

### READ ALL INSTRUCTIONS BEFORE USING THIS MACHINE.

#### **WARNING**

#### To reduce the risk of fire, electric shock, or injury:

- Use only indoors. Do not use outdoors or expose to rain.
- Store the machine indoors where temperature is between 32° and 104°F (0° and 40°C).
- Use only as described in this manual. Use only manufacturers recommended components and attachments.
- If the machine is not working properly, has been dropped, damaged, left outdoors, or dropped into water, return it to an authorized service center.
- Do not operate the machine with any openings blocked. Keep openings free of debris that may reduce airflow.
- Machine can cause a fire when operating near flammable vapors or materials. Do not operate this machine near flammable fluids, dust or vapors.
- This machine is suitable for commercial use such as: in hotels, schools, hospitals, factories, shops, and offices for more than normal housekeeping purposes.
- Maintenance and repairs must be done by qualified personnel.
- During operation, use caution around other persons, especially children.
- The machine shall only be operated by instructed and authorized persons.
- When leaving unattended, unplug the machine.
- Do not handle the plug or machine with wet hands.
- Do not unplug machine by pulling on cord. To unplug, grasp the plug and not the cord.
- Do not use with damaged cord or plug. Follow all instructions in this manual concerning grounding the machine.
- Do not pull or carry by cord, use cord as a handle, close a door on cord, or pull cord around sharp edges or corners.
- Do not pull/run machine over cord. Keep cord away from heated surfaces.
- Connect to a properly grounded outlet. See Grounding Instructions.
- If the supply cord is damaged it must be replaced by an authorized service agent.
- Unplug before cleaning or servicing.
- Operational hazard may occur when running the machine over the supply cord.
- This appliance has been designed for use with pads specified by the manufacturer. The fitting of other pads may affect its safety.
- This machine is for dry use only and shall not be used or stored outdoors in wet conditions
- Moving Parts - To reduce the risk of injury, unplug before servicing.

### READ AND SAVE THESE INSTRUCTIONS

# SAFETY

The following symbols are used throughout this guide as indicated in their descriptions:

## HAZARD INTENSITY LEVEL

There are three levels of hazard intensity identified by signal words -**WARNING**, **CAUTION**, and **FOR SAFETY**. The level of hazard intensity is determined by the following definitions:



**WARNING** - Hazards or unsafe practices CAN result in severe personal injury or death.



**CAUTION** - Hazards or unsafe practices which could result in minor personal injury or product or property damage.

**FOR SAFETY:** To identify actions which must be followed for safe operation of equipment.

Report machine damage or faulty operation immediately. Do not use the machine if it is not in proper operating condition. The following is information that signals some potentially dangerous conditions to the operator or the equipment. Read this information carefully. Know when these conditions can exist. Locate all safety devices on the machine. Please take the necessary steps to train the machine operating personnel.

### **FOR SAFETY:**

DO NOT OPERATE MACHINE:

- Unless trained and authorized.
- Unless Operation Guide is read and understood.
- In flammable or explosive areas.
- In areas with possible falling objects.

WHEN SERVICING MACHINE:

Avoid moving parts. Do not wear loose clothing, jackets, shirts, or sleeves when working on the machine. Use only manufacturer approved replacement parts.

## GROUNDING INSTRUCTIONS 120V

THIS PRODUCT IS FOR COMMERCIAL USE ONLY

**ELECTRICAL:** In USA this machine operates on a 15 amp nominal 120V, 60 hz, A.C. power circuit. The amp, hertz, and voltage are listed on the data label found on each machine. Using voltages above or below those indicated on the data label will cause serious damage to the motors.

**GROUNDING INSTRUCTIONS:** This appliance must be grounded. If it should malfunction or break down, grounding provides a path of least resistance for electric current to reduce the risk of electric shock. This appliance is equipped with a cord that has an equipment-grounding conductor and grounding plug. The plug must be inserted into an appropriate outlet that is properly installed and grounded in accordance with all local codes and ordinances.

For use on a nominal 120 volt circuit with a grounded plug that looks like the plug in FIGURE A. A temporary adaptor that looks like the adaptor in FIGURE C may be used to connect this plug to a 2-pole receptacle as shown in FIGURE B, if a properly grounded outlet is not available. The temporary adaptor should be used only until a properly grounded outlet (FIGURE A) can be installed by a qualified electrician. The green colored rigid ear, lug or similar that extends from the adaptor must be connected to a permanent ground such as a properly grounded outlet box cover. Whenever the adaptor is used, it must be held in place by a metal screw.

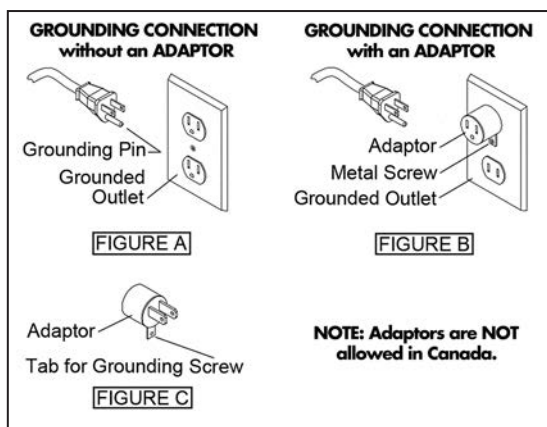

## WARNING

Improper connection of the equipment-grounding conductor can result in electric shock. Check with a qualified electrician or service person if you are in doubt as to whether the outlet is properly grounded. Do not modify the plug provided with the appliance - if it will not fit the outlet, have a proper outlet installed by a qualified electrician.

**EXTENSION CORDS:** It is recommended to only use the supplied power cord. However, when the use of an extension cord is unavoidable, use only three-wire 12/3 or larger gauge approved extension cords that have threeprong grounding type plugs and three-pole receptacles that accept the machine's plug. Replace or repair any damaged cords or plugs.

**SAFETY LABEL LOCATION:** If at any time the safety labels become illegible, contact your authorized representative for prompt replacement.

## TECHNICAL DETAILS

ITEM	SPECIFICATIONS
Motor	1HP, 1400W, 6-12amp, 100-240V, 50/60Hz
Dual Speed	1725 RPM (Orbital), 80 RPM (Rotational)
Drive Diameter	19" (48.26 cm)
Wheel Diameter	10" (25.4 cm)
Quick-Connect Power Cord	50 ft. (15m)
Solution Tank Capacity	3 Gallon (11.4L)
Pump	90 PSI (6.2 BAR)
Noise Level	59 dB
Height	48" (122 cm)
Length	29" (75 cm)
Weight	107 Lbs./48.5 Kg





## Unpacking and Initial Operations

Open shipping box (both sides). Remove packaging material and roll machine out of box.

### Pre-Run Inspection

Before each use, inspect for cracks, tears or excess wear. If the machine or accessory is dropped, inspect for damage. Then repair or replace, if necessary, before use.

**1** - Tilt head back and place the foot of bumper on the ground. Choose a pad for the appropriate application. **2** - Center the pad on driver plate. **3** - Then position handle in a lower position. **4** - Push slowly forward until machine base tilts towards the ground.

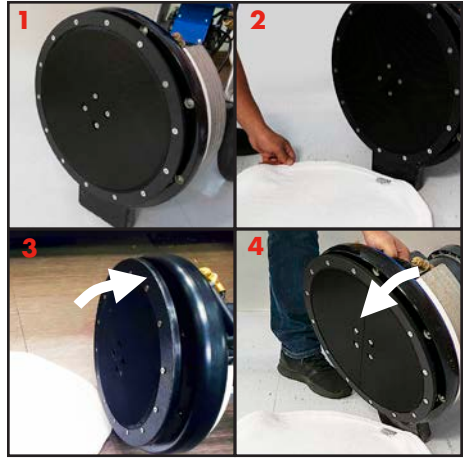

### **!** CAUTION

Make sure to put the wheels back on the ground in time to avoid the base from falling on the ground. This might cause damage!

Check that the power switch is in the "off" position.

### Power Cable / Quick Disconnect

Take provided power cable and connect to machine quick disconnect located on machine. Push and twist to lock cables together. Plug power cord into outlet.



### **!** WARNING

### Spray System Preparation

Fill bottle cartridge with suggested cleaning solution.

Prime pump system by moving valve lever to the vertical position and depress spray switch for 30 seconds.

By adjusting valve lever you can vary spray pressure. The further you move the lever counterclockwise upwards, the higher the water pressure. A horizontal position means maximum water output at maximum pressure.

To turn the machine on, press the power button on the end of the left handle.

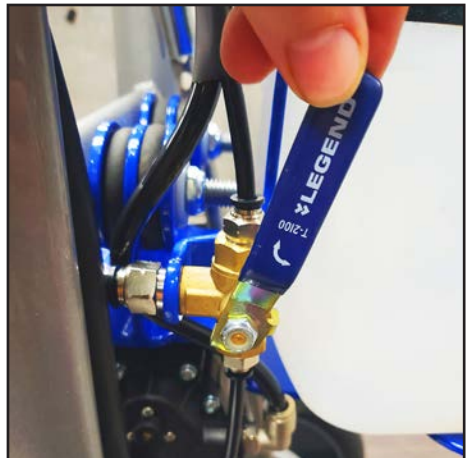

## OPERATION

### Spray Jets

Adjust spray jets on machine base to the desired position. For most floor cleaning applications, adjust spray jets so they spray about 6 inches (15 cm) in front of the base.

### Adjusting Height

Set handle position to desired height by pulling and releasing the black knob with the left hand.

While holding the black knob out, raise or lower the handle frame with your right hand.

To secure handle frame, release the black knob so that it locks firmly into one of the holes provided.

Position "0" is off and position "1" is on.



### **!** CAUTION

Make sure a suitable pad or brush is mounted before starting the machine. The immediate contact to floor and driver plate, without a pad, can lead to serious damage to the floor and/or the machine.

### Process of Cleaning

For effective floor cleaning, move the machine forward and backwards. It is recommended to wet the floor as you move the machine forward, releasing the solution button when you move the machine backwards.

To increase the pressure and cleaning effect on certain floor types like tile and grout, you can lift the machine frame up, raising the wheels off the ground. When lifting the wheels off the ground the full weight of the machine lies on the machine base.

### **!** CAUTION

Make sure the surface to be cleaned is not damaged by the increase in pressure.

Omit this measure on very sensitive floors.



## End of the Application

Turn off the machine by putting the on/off switch to "O". If a cleaning solution was used, fill bottle cartridge with water and spray out system for 30 seconds. Make sure to not let solution come in contact with the motor.

## Storage

To avoid damage to the handle frame, do NOT lay machine frame on floor as done with other traditional cleaning equipment. Remove the pad from the driver plate by pulling it down firmly. Put machine frame in an upright position by pulling the black knob with the left hand and move the handle frame upwards with the right hand. The black knob should lock firmly in the top hole.



## ⚠ CAUTION

To allow for easy transportation of the machine, remove the weight kit if used. Use tie down straps to secure the machine to the truck or trailer during transport. It is recommended to completely drain or remove the solution tank prior to transporting.



To easily roll machine, push your foot on the back wheel axle and pull handle towards you. Moving machine similar to a dolly. Always store with the base in the upright position.

## Lifting and Carrying

Without a ramp, we recommend 2 people to lift machine in and out of vehicle setting wheels down first, then base. Lock handle in a lower position. Make sure that the machine base rests on a pad, so that the grip surface of the driver plate does NOT get damaged or hooked onto a carpeted surface.



## ⚠ WARNING

Grip the machine from each side as shown. Do NOT grip too close to the machine base. If the base should flip upwards it can cause serious hand injury.

Lift machine with a back-friendly posture. And then secure machine firmly so it will not move.

## OPERATION

### Weight Kit Installation

Place the weight kit (40 lbs.) on top of the mounting plates located on the sides of the machine base.

Put the 4 screws into the holes provided on the weight plates and fasten by turning clockwise.

Once the screws have threaded at least 5 full turns, tighten wing nuts by turning clockwise, until the weights fit securely to the base.



### CAUTION

Make sure that the weights are securely attached to the base. Loose weights can cause serious damage.

For storage and transport, we recommend removing the weight kit. The machine can be transported more easily without the weights.

### Brush Installation

Put the machine base in an upright position, sitting on the foot of the bumper. Remove the driver plate by removing the four countersink screws in the center of the plate using an electric screwdriver.



### WARNING

It is important to only use a # 3 Phillips head screwdriver bit. Smaller bit sizes can damage the screw heads and leave sharp edges, which can tear or snag the pads. Damaged screws can cause further damage.

Mount the brush with the same countersink screws used for mounting the driver plates.

- **NOTE:** Tighten the screws sufficiently to avoid disengagement of the brush from the machine during operation.

To avoid stripping the screws, do NOT over tighten. An electric screwdriver with a clutch will ensure that stripping will NOT occur.



## Attaching and Removing the Driver Plates

Put the machine base in an upright position, sitting on the foot of the bumper.

Remove the driver plate by removing the four countersink screws in the center of the plate using an electric screwdriver.

Attach a driver plate to the machine base by lining up the holes of the driver plate with the appropriate threads of the bearing retainer ring.

It is recommended to align the threads of the bearing horizontally to the ground.

Put the 4 countersink screws through the holes of the driver plate and first screw them into the bearing retainer ring threads manually. Then, tighten the screws with an electric screwdriver



### **! WARNING**

It is important to only use a # 3 Phillips head screwdriver bit. Smaller bit sizes can damage the screw heads and leave sharp edges, which can tear or snag the pads. Damaged screws can cause further damage.

- **NOTE:** Tighten the screws sufficiently to avoid disengagement of the driver plate from the machine base during operation.

To avoid stripping the screws, do NOT over tighten. An electric screwdriver with a clutch will ensure that stripping will NOT occur.

## ACCESSORIES AND APPLICATIONS

### **! WARNING**

Never store the accessories in wet conditions. Keep the accessories away from extreme heat and from chemicals.

## OPERATION

### Multi-Floor Velcro Driver Plate

Exclusively use designated driver plates only. Using other driver plates will damage the machine and its mechanical action. Driver plates are fastened on the machine base with four countersink screws.

The 19" driver plate supplied is suitable for all pads on textile and hard floor applications. Pads can be easily attached and removed from the driver disc.

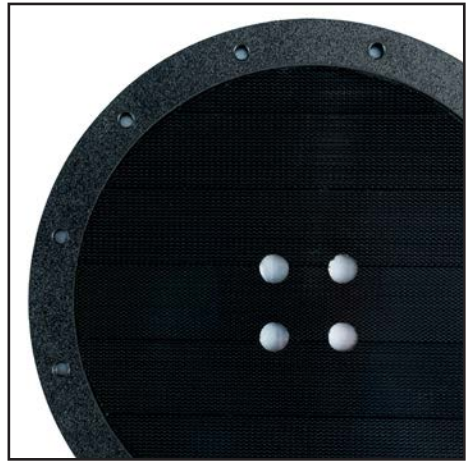

### **!** WARNING

Never place driver on carpet without a pad attached. May cause damage to the floor.

### AgiClean Pad

The beige AgiClean pad is made of a special blend of fibers and latex that allows gentle cleaning of heavily soiled short-pile carpets as well as scrubbing of hard floors. Attach the AgiClean pad by centering onto the driver plate.

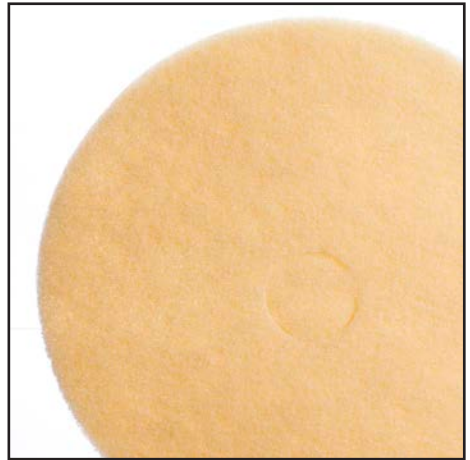

AgiClean pads, used on both sides, cleans an approximate area of 3,000 sq. ft. (280m<sup>2</sup>), depending on floor type and level of soil. Rinse the AgiClean pads after each use with clean water.

### SuperZorb Pad

Our exclusive SuperZorb pad is made of a special cotton and polyester blend. One of the primary components that help to extract an essential amount of soil from the carpet fibers. They also play an important role to achieve fast dry times.

SuperZorb pads, used on both sides, cleans approximately 30,000 sq. ft. (2800m<sup>2</sup>) with up to 100 washes. This of course depends upon floor type and level of soil. SuperZorb pads are also machine washable. Allow to air dry.



**UltraLift Pad**

The UltraLift pad can be used on stone, concrete, VCT, marble and porous surfaces.

Each pad can clean an approximate area of 4,000 sq. ft. (372m<sup>2</sup>) depending on floor type and level of soil.

**AkwaStrip Pad**

The AkwaStrip pad is a chemical free stripping pad made of a unique material filled with diamonds. Used for deep cleaning and to remove wax off of vinyl, VCT, linoleum, wood, safety tiles and more. Used on both sides, can clean approximately 2,500 to 5,000 sq. ft. (230 to 460m<sup>2</sup>), depending on floor type and the level of wax/soil. Thoroughly rinse with clean water after use.



## OPERATION

### Multi-Purpose Scrub Brush

The bristles of the brush are made of high quality nylon. The unique brush design is ideal for cleaning tile and grout, smooth concrete, rubber flooring and other microporous surfaces such as porcelain and safety tiles. It can also be used for any other hard surfaces.

### ⚠ CAUTION

The use of the multi-purpose brush may splash in certain applications. Take appropriate measures or use a splash guard to prevent the wetting of walls and other obstacles.

Rinse the brush as needed with clean water after each use. Depending on usage and care, you can use the multi-purpose brush for many years.

- **NOTE ON STORAGE:** Never store the multi-purpose brush with the bristles down. This can deform the bristles, damage the brush, and reduce the cleaning performance.

You can bring deformed bristles back into their original form by heating them with a heat gun.

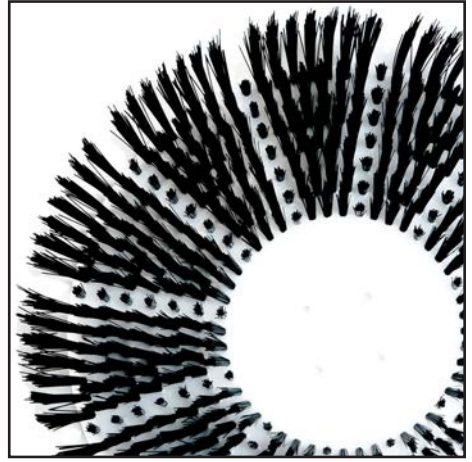



## APPLICATION ON DIFFERENT FLOORS

### Carpet Cleaning

Vacuum the carpet thoroughly before cleaning. Large dirt particles are removed, allowing the application to be more effective.

Apply solution while moving forward. Clean by going forward and backwards 2 to 3 times, while applying solution on the first pass in order to keep the drying time low. Depending on soil level and nature of the carpet, this process can be shortened or extended. As required, carpets can be vacuumed again after cleaning.



### Cleaning Hard Floors

Remove dust and coarse dirt from the surface before cleaning. Choose a suitable pad according to the application. Place the pad in the center of the driver. Gently lower the head on to the floor. Moving forward and backwards while adding water to the surface. Use cleaning solution as needed. Depending on soil contamination and floor type, this process can be shortened or extended.

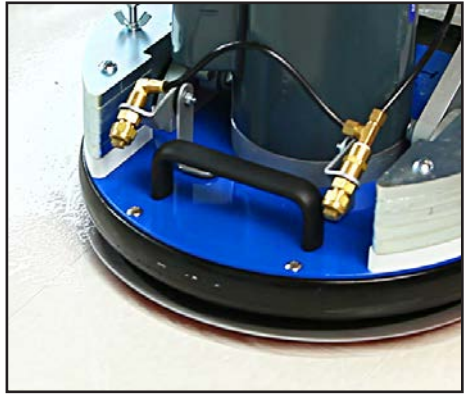

### Cleaning the Machine

Clean the machine and bearing with a soft cloth and a neutral pH cleaner. Regular cleaning of the bearing is required to prevent build up that will cause it to seize up.

### Changing the Driver Grip Face

Remove the 10 outer screws that fasten the grip face disc on the driver plate. To save time, use an electric screwdriver with a #3 Phillips head bit.

## WARNING

The #3 Phillips head bit is slightly larger than standard size. It is important that you are using a #3 Phillips head bit, as smaller bits can damage the screw heads and produce sharp edges which can damage the cleaning pads. Attach a new grip face disc to the driver plate using the 10 screws.

Make sure that the screws are very tight, not loose. If the screws are too loose, it can cause damage to the grip face disc. Ensure that the 4 holes in the middle of the grip face disc are aligned with the screws located on the driver plate. An exact alignment allows an easy removal and installation of the driver plate.

## HANDLE ADJUSTMENT ASSEMBLY

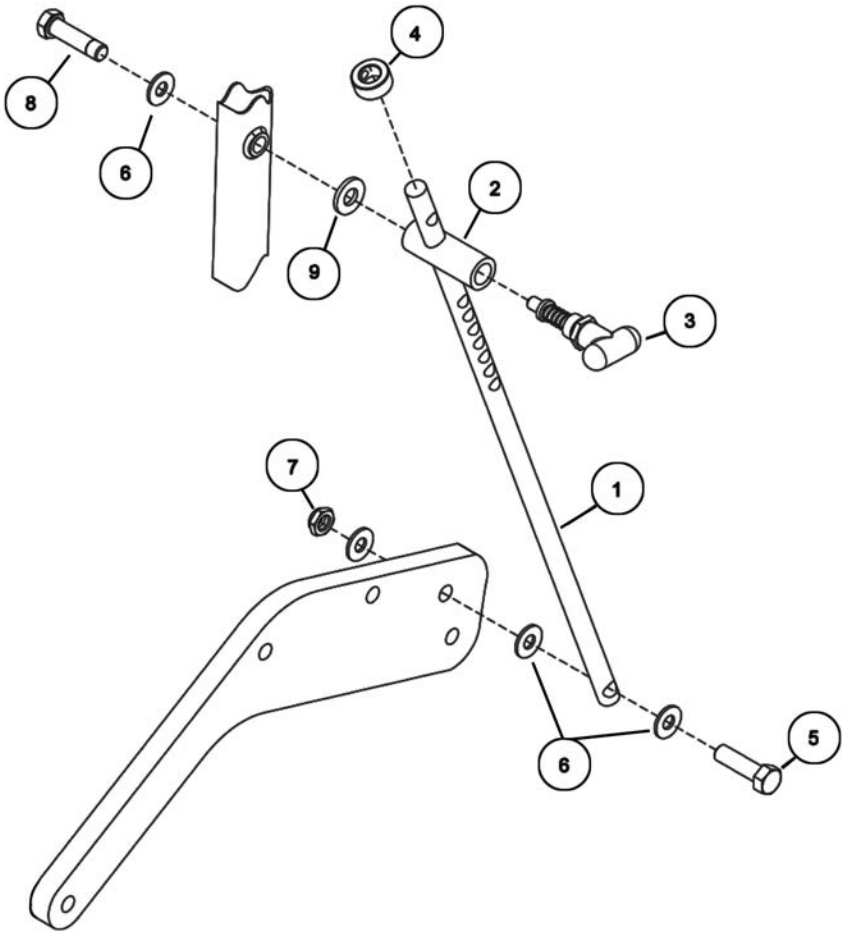

ITEM NO	PART NUMBER	QTY	DESCRIPTION
1	570151	1	ROD, HANDLE
2	570149	1	PULL LATCH BODY
3	570150	1	PULL LATCH
4	570037	1	SHAFT COLLAR
5	570129	1	SCREW, 1/2-13 X 2"
6	570152	3	WASHER, NYLON, 1/2"
7	570132	1	HEX NUT, LOCK, .5-13 X .75W X .312
8	570129	1	SCREW, 1/2-13 X 2"
9	570131	2	WASHER, PLASTIC, .5 ID X 1.125 OD X .125 THK

## SOLUTION TANK & CAGE ASSEMBLY

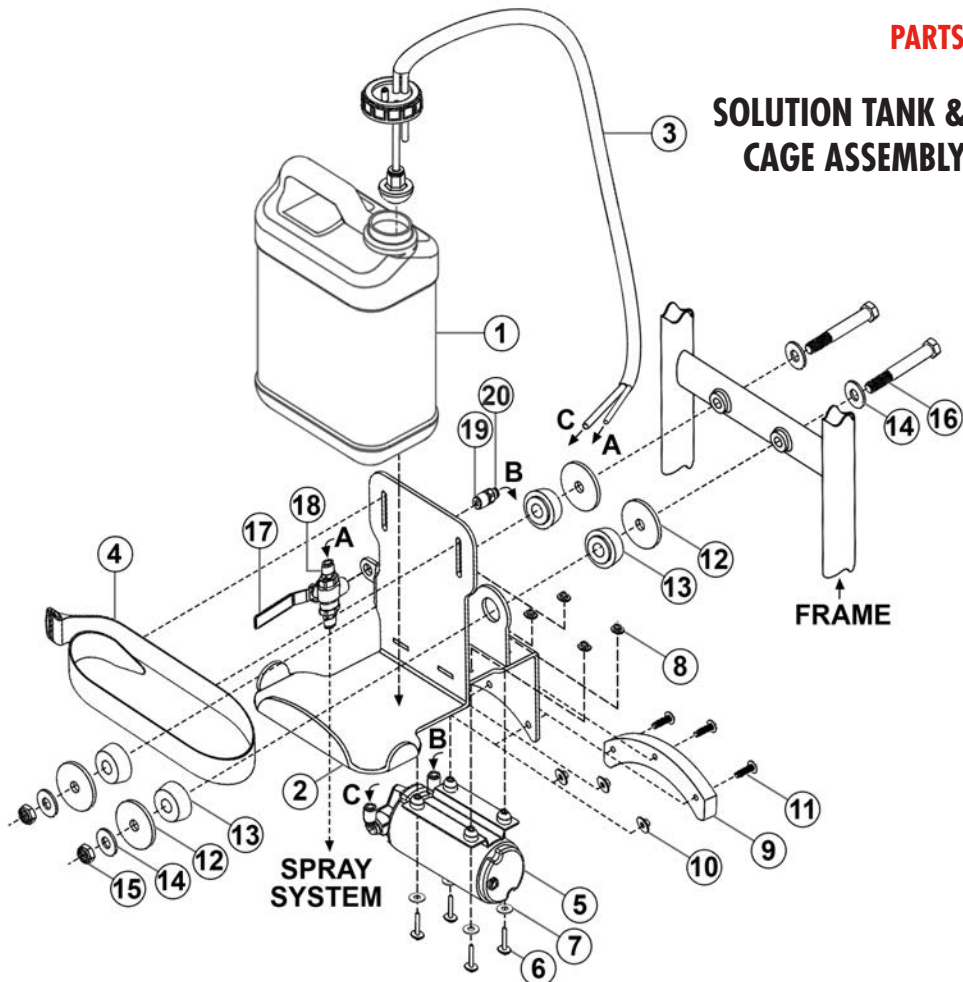

ITEM NO	PART NUMBER	QTY	DESCRIPTION
1/2	570065 / 570156	1/1	BOTTLE CARTRIDGE, 3-GALLON / CAGE ASSY
3/4	570179/ 570174	1/1	BOTTLE CAP ASSY/ VELCRO STRAP, 2" X 36"
5/6	570171/570059	1/4	PUMP, (DOMESTIC)/SCREW, 6-32 X 1-1/4"
7/8	570060/570061	4/4	WASHER, PUMP MOUNT / HEX NUT, 6-32, NYLOCK
9	570182	1	STOP, CAGE/MOTOR
10/11	570138/570137	3/3	BUMPER INSERT/SCREW, 1/4-20 X 1" X 3/16"
12/13	570181/ 570067	4/4	WASHER, ID .5", OD 2.25"/ DAMPNER, RUBBER
14	570131	2	WASHER, PLASTIC, .5" ID X 1.125" OD X .125 THK
15	570132	2	HEX NUT, LOCK, .5-13 X .75W X .312
16	570180	2	SCREW, 1/2-13 X 4-1/2"
17	570165	1	VALVE, FLOW CONTROL, 3-WAY
18	570166	2	COUPLER, QD, FLOW CONTROL
19/20	570167/570168	1/1	NIPPLE, HEX, PIPE, 1/4"/ COUPLER, FLOW CONTROL

**MOTOR & BASE ASSEMBLY**

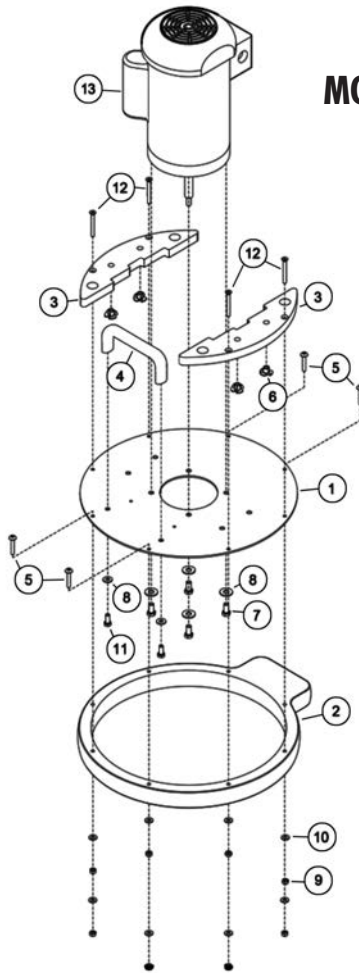

ITEM NO	PART NUMBER	QTY	DESCRIPTION
1	570184	1	BASE, .1875 THK
2	570075	1	BUMPER, 19"
3	570120	2	WEIGHT PLATE ASSEMBLY
4	570078	1	HANDLE, BASE
5	570185	4	SCREW, 1/4-20 X 1-1/2"
6	570119	4	NUT, 1/4-20 X 5/16, TEE, 4 PRONG
7	570114	4	SCREW, 3/8-16 X 3/4"
8	570115	6	WASHER, FLAT .38 ID X 1 OD X .06THK
9	570076	8	HEX NUT, LOCK, BUMPER MOUNT
10	570077	8	WASHER, 1/4 ID X 5/8 OD X .06 THK
11	570079	2	SCREW, 5/16-18 X 3/4"
12	570195	4	SCREW, 1/4-20 X 2-1/4"
13	570189	1	MOTOR, 110/220V, 1750 RPM

## WHEEL KIT ASSEMBLY

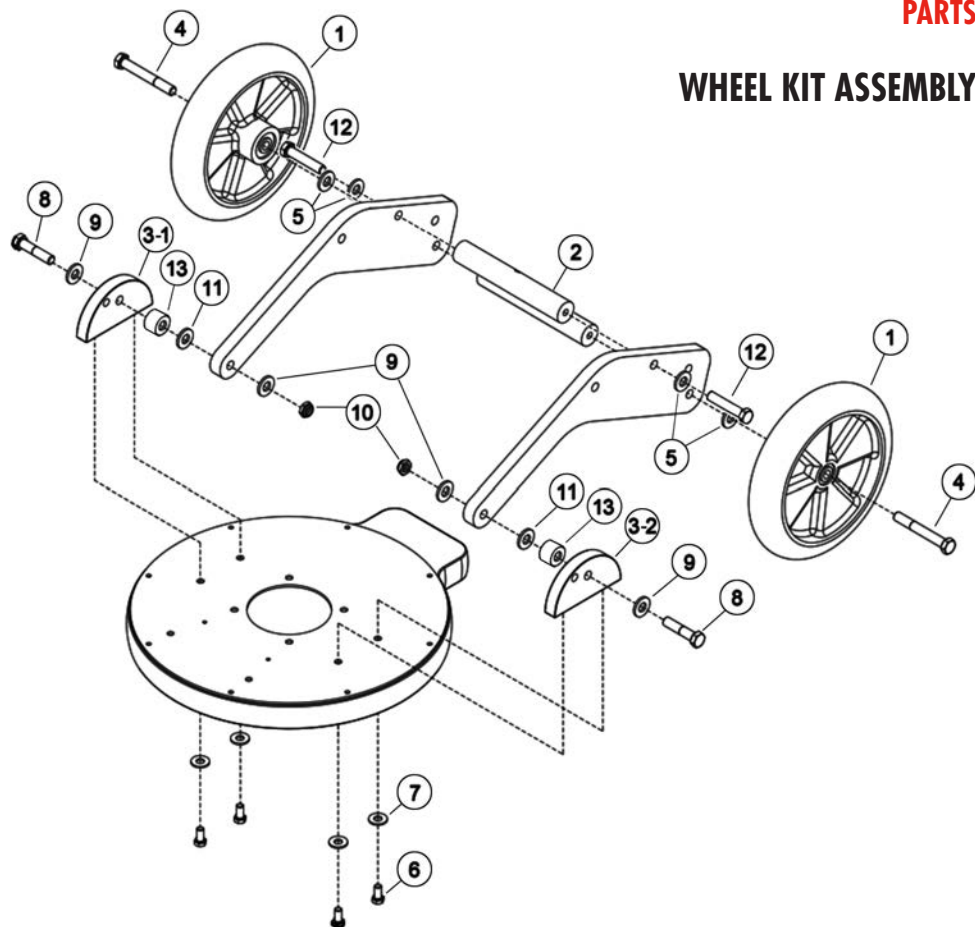

ITEM NO	PART NUMBER	QTY	DESCRIPTION
1	5701283	2	WHEEL, 10"
2	570199	2	ROD, WHEEL
3 - 1	570080	1	LEFT EAR, WITH PIN
3 - 2	570081	1	RIGHT EAR, WITH PIN
4	570200	2	SCREW, .5-13 X 3-3/4"
5	570131	4	WASHER, PLASTIC, .5 ID X 1.125 OD X .125 THK
6	570114	4	SCREW, HEX HEAD, 3/8-16 X 3/4"
7	570115	4	WASHER, .38 ID X 1" OD
8	570130	2	SCREW, .5-13 X 2-1/4"
9	570131	4	WASHER, PLASTIC, .5 ID X 1.125 OD X .125 THK
10	570132	2	HEX NUT, LOCK, .5-13 X .75W X .312
11	570005	2	WASHER, NYLON, .812" ID X 1.057" OD
12	570129	2	SCREW, .5-13 X 2"
13	570068	2	BUSHING, PLASTIC, .75" OD X .5" ID X 1.625"

# PARTS

## LOWER HANDLE / FRAME ASSEMBLY

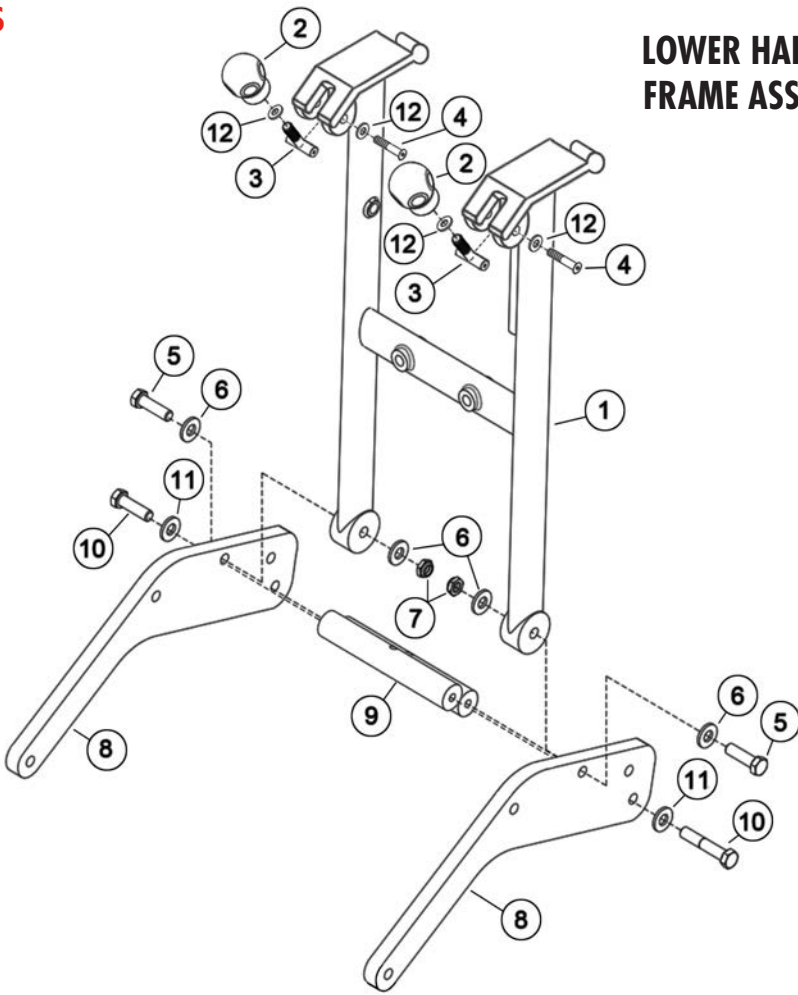

ITEM NO	PART NUMBER	QTY	DESCRIPTION
1	570139	1	HANDLE ASSY, LOWER
2	570027	2	KNOB, LOCKING POSITION
3	570028	2	"T" SCREW, KNOB, HANDLE
4	570026	2	SCREW, 1/4"-20 X 1.5", LOWER HINGE
5	570129	2	SCREW, .5-13 X 2"
6	570131	4	WASHER, PLASTIC, .5 ID X 1.125 OD X .125 THK
7	570132	2	HEX NUT, LOCK, .5-13 X .75W X .312
8	570198	2	ARMS, LEFT & RIGHT
9	570199	2	ROD, BRACE
10	570200	2	SCREW, .5-13 X 3-3/4"
11	570131	2	WASHER, PLASTIC, .50 ID X 1.125 OD X .125 THK
12	570036	4	WASHER, NYLON, KNOB & HINGE ASSY

# UPPER HANDLE / FRAME ASSEMBLY

**PARTS**

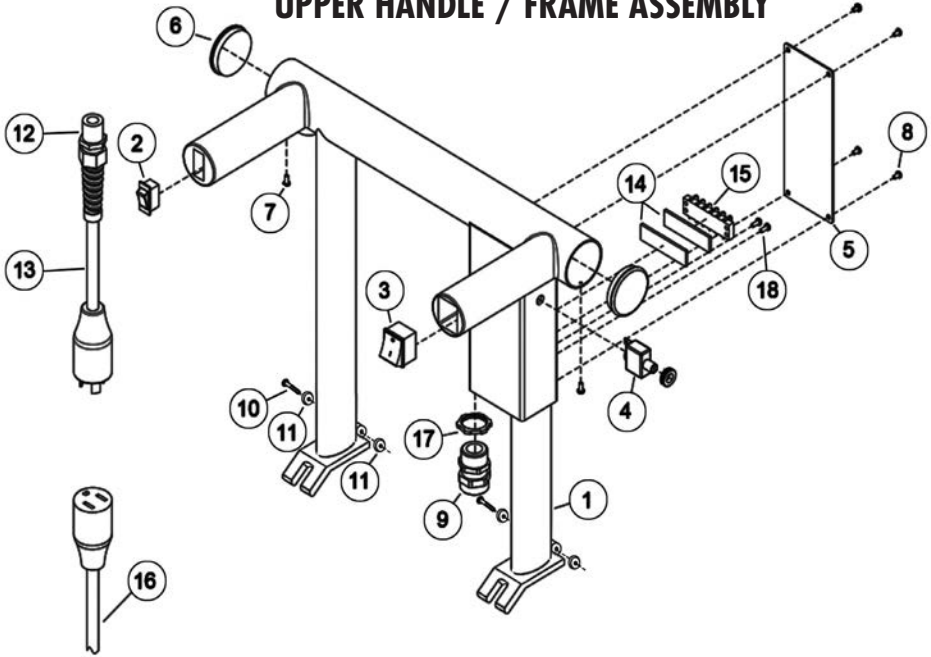

ITEM NO	PART NUMBER	QTY	DESCRIPTION
1	570019	1	HANDLE ASSY, UPPER, W/ELECTRICAL BOX
-	570193	1	HARNESS, MAIN HANDLE, 7 CONDUCTOR
2	570030	1	SWITCH, ROCKER, SPRAYER, DOUBLE POLE
-	570144	1	HARNESS, SPRAYER SWITCH
3	570029	1	SWITCH, ROCKER , ON/OFF, DOUBLE POLE
-	570143	1	HARNESS, ON/OFF SWITCH
4	570146	1	BREAKER, 20A 125/250VAC 32VDC
5	570147	1	COVER PLATE, ELECTRICAL BOX
6	570032	2	TUBE CAP, HANDLE, 2" DIA
7	570033	2	SCREW, 6-20 X 3/8", TUBE CAP
8	570031	4	SCREW, 8-32 X .25", ELECTRICAL BOX COVER
9	570111	1	WIRE MOUNT, MOTOR, 1"
10	570025	2	SCREW, 3/8"-16, 1.25", UPPER HINGE
11	570036	4	WASHER, NYLON, KNOB & HINGE ASSY
12	570034	1	STRAIN RELIEF, POWER CORD
13	570051	1	HANDLE CORD / PIGTAIL, 110V, YELLOW (US)
14	570155	1	VELCRO, TERMINAL SWITCH
15	570145	1	TERMINAL SWITCH
16	570038	1	POWER CORD ASSY, 50' w/PLUGS, YELLOW
17	570110	1	LOCK NUT, 1", ELECTRICAL BOX
18	570154	2	SCREW, 8-32 X 3/8", TERMINAL GROUND

# PARTS

# MOTOR ASSEMBLY

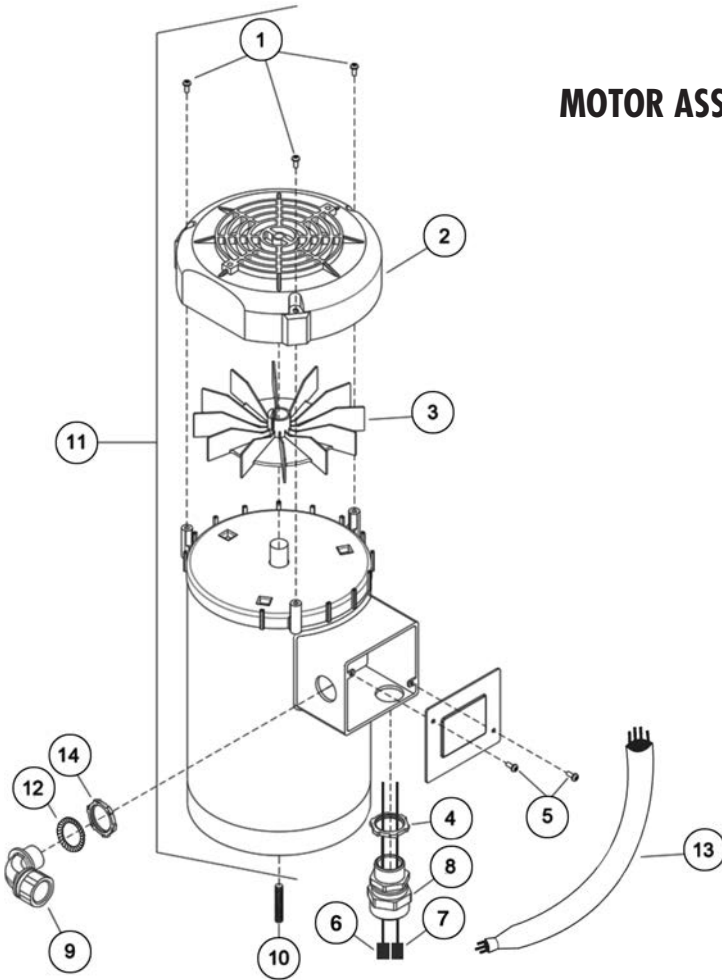

ITEM NO	PART NUMBER	QTY	DESCRIPTION
1	570102	3	SCREW, FAN COVER, 10-32 X 3/8"
2	570101	1	COVER, MOTOR FAN
3	570100	1	FAN, MOTOR
4	570110	2	LOCK NUT, 1", ELECTRICAL BOX
5	570191	2	SCREW, MOTOR LID
6	570112	1	CORD, BLUE PLUG, 100-120V, PUMP
7	570113	1	CORD, BLACK PLUG, 100-120V, AUX
8	570111	1	CORD GRIP, 1", ELECTRICAL BOX
9	570109	1	ELBOW, 3/4", ELECTRICAL BOX
10	570103	1	SOCKET SET SCREW, 3/8-24 X 1-1/2"
11	570189	1	MOTOR, 110/220V, 1750RPM
12	570099	1	WASHER, SERRATED, 3/4", CORD GRIP
13	570193	1	BODY CORD
14	570148	1	LOCK NUT, 1/2", ELECTRICAL BOX



## SPRAY NOZZLE ASSEMBLY

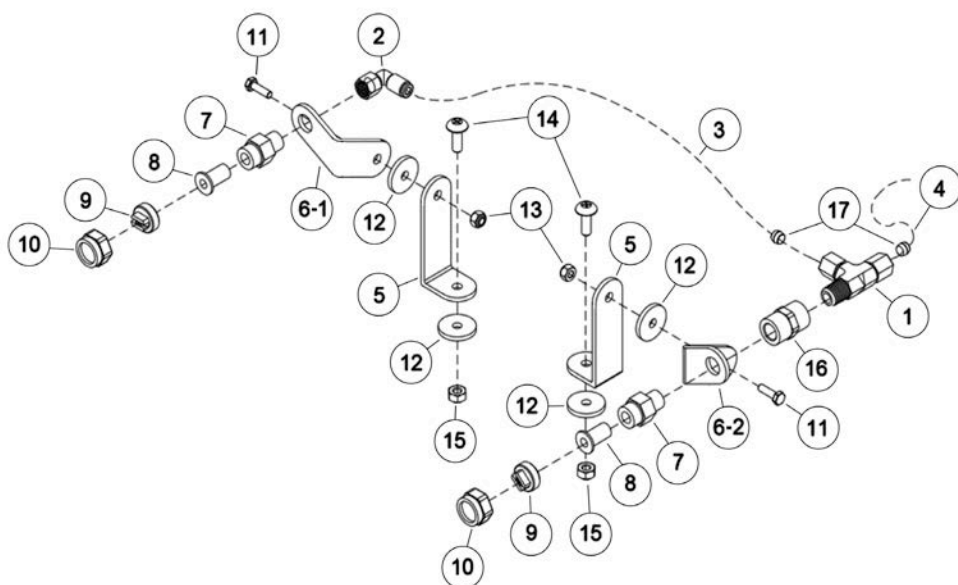

ITEM NO	PART NUMBER	QTY	DESCRIPTION
1	570092	1	QUICK CONNECT, 1/4", TEE, SPRAY NOZZLE
2	570095	1	ELBOW, 1/4", 90°, SPRAY NOZZLE
3	570096	1	HOSE, SPRAY JET
4	570097	1	T-HOSE, SPRAYJET
5	570082	2	L-BRACKET, NOZZLE BASE
6 - 1	570083	1	SPRAY BRACKET, TOP LEFT
6 - 2	570084	1	SPRAY BRACKET, TOP RIGHT
7	570090	2	SPRAY JET BODY
8	570089	2	STRAINER, CHECK VALVE
9	570088	2	SPRAY JET TIP
10	570091	2	SPRAY CAP
11	570085	2	SCREW, 10-32 X 3/4"
12	570087	2	WASHER, SPRAY JET ARM
13	570086	2	NUT, 10-32 HEX, NYLOCK
14	570116	2	SCREW, 1/4-20 X 3/4"
15	570117	2	NUT, 10-32 HEX NYLOCK
16	570094	1	COUPLER, FLOW JET
17	570093	2	SLEEVE, COMPRESSION

**DISC DRIVER ASSEMBLY**

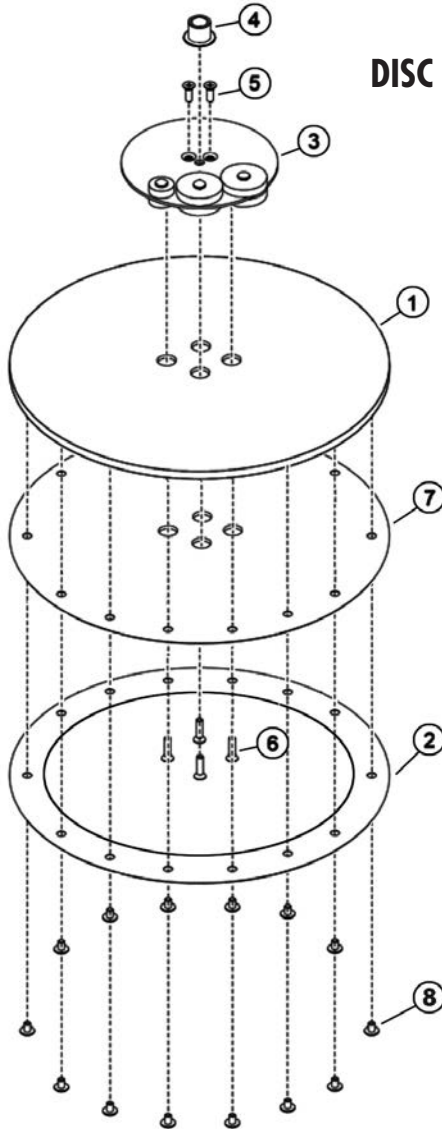

ITEM NO	PART NUMBER	QTY	DESCRIPTION
1	570316	1	DRIVER, DISC, 19"
2	570315	1	RING, MULTI-FLOOR DRIVER, 19"
3	570105	1	COUNTER WEIGHT ASSY, w/BEARING
4	570104	1	SHAFT SUPPORT
5	570106	2	SCREW, 1/4-20 X 3/4"
6	570121	4	SCREW, 1/4-20 X 1"
7	576601	1	PAD, VELCRO
8	570118	14	SCREW, 1/4-20 X 3/8"

# WIRING DIAGRAM

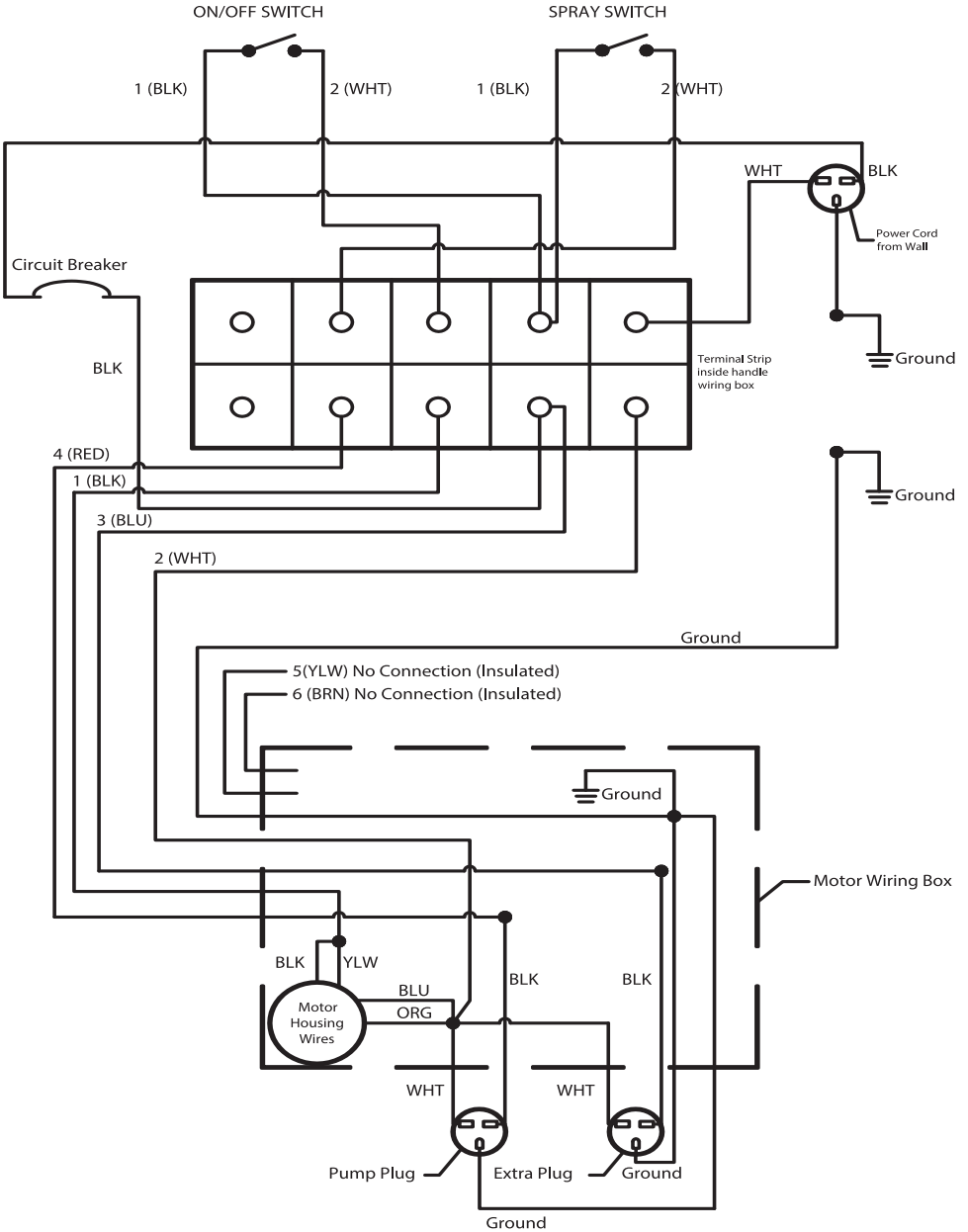



Powered by  
**ORBOT**®

2259 Sheridan Drive, Muskegon, MI 49442, USA  
P: 800-968-1332 | [orders@PacificFloorcare.com](mailto:orders@PacificFloorcare.com)

[www.PacificFloorcare.com](http://www.PacificFloorcare.com)

**PURPOSE BUILT to CLEAN ANY FLOOR!**

---