



**PACIFIC**<sup>®</sup>  
F L O O R C A R E

**QS-12**

**6 GALLON QUICK SCRUB**



Thank you for purchasing a Pacific Floorcare product. Carefully inspect all components for freight damage. If such damage is discovered, file a “CONCEALED DAMAGE REPORT” immediately with the delivering carrier.

Read this manual carefully and keep it near the machine, protected from liquids and other damaging substances. Failure to operate the QS-12 in accordance with the Safety Information provided in this manual may result in injury, damage to property, damage to the machine, or premature failure of components. Read before use. Damage or equipment failure caused by improper use, abuse, or neglect is not covered under warranty.

The contents of this manual are based on the latest product information available at the time of publication. Pacific Floorcare reserves the right to make changes or improvements without being obliged to apply changes to the machines previously sold.

New manuals can be downloaded from: [www.pacificfloorcare.com/manuals](http://www.pacificfloorcare.com/manuals)

# 6 GALLON QUICK SCRUB SPECIFICATIONS

Features	Specifications
Model	QS-12
<b>Machine Specifications</b>	
Length	24 in ( 61 cm)
Width	19 in ( 48.3 cm)
Height	36 in ( 91.4 cm)
Weight w/ Std Batteries	110 lbs (49.9 kg)
Weight w/ Opt'l Batteries	131 lbs (59.4 kg)
Sound level	68 dBA
Construction	Rotationally molded polyethylene tanks, powder coated steel frame
<b>Solution Delivery System</b>	
Solution Capacity	5.5 gal (20.8 L)
Solution Control	0.0 - 0.38 gpm (0.0 - 1.44 L/min)
Solution Control Settings	Manual Trigger
<b>Scrubbing System</b>	
Cleaning Path	12 in (30.5 cm)
Pad/Brush Size	12 in (30.5 cm) Brush
Scrub Head Height	3.6 in (9.2 cm)
Handle Height	55.5 in (141 cm)
<b>Recovery System</b>	
Recovery Tank Capacity	6 gal (22.7 L)
Recovery Tank Accessibility	Full Clean-Out Access
Vacuum Motor	210 W, Single Stage
Vacuum Motor cfm/cmm	55.7 cfm (1.58 cubic m <sup>3</sup> /min)
Vacuum Motor Water-lift	29.8 in (75.5 cm)
Squeegee Width	12 in (30.5 cm)
Squeegee Material	Primothane®
<b>Battery System</b>	
System Voltage	12 V
Battery Amp/Hour Rating (Std)	26 Ah
Battery Run Time (Std)	Up to 1.4 hours
Battery Amp/Hour Rating (Opt'l)	61 Ah
Battery Run Time (Opt'l)	Up to 3.5 hours
Charger Description	On-Board
*Note: Specifications subject to change without notice	

# TABLE OF CONTENTS

<b>SAFETY INFORMATION .....</b>	<b>1</b>
<b>MACHINE OVERVIEW .....</b>	<b>3</b>
<b>OPERATION.....</b>	<b>4</b>
<b>INSPECTION &amp; CLEANING.....</b>	<b>5</b>
<b>SQUEEGEE &amp; BRUSH ASSEMBLY REPLACEMENT .....</b>	<b>6</b>
<b>BATTERY &amp; CHARGING .....</b>	<b>7</b>
<b>SOLUTION TANK &amp; Q-CAPST<sup>™</sup> CHEMICAL SYSTEM .....</b>	<b>8</b>
<b>RECOMMENDED MAINTENANCE.....</b>	<b>9</b>
<b>PARTS DIAGRAMS.....</b>	<b>11</b>
FRAME ASSEMBLY .....	11
TANK ASSEMBLY .....	13
COVER ASSEMBLY.....	15
HANDLE ASSEMBLY.....	17
SCRUB HEAD ASSEMBLY.....	19
STORAGE CADDY ASSEMBLY.....	21
ADJUSTABLE HANDLE ASSEMBLY.....	23
<b>ELECTRICAL SYSTEM.....</b>	<b>25</b>
ELECTRICAL COMPONENTS LIST .....	25
ELECTRICAL DIAGRAM .....	26



# SAFETY INFORMATION



This machine is intended for commercial use. Only use recommended pads or brushes and commercially approved floor cleaning chemicals intended for the application.

**WARNING:** A potentially hazardous situation that, if not avoided, could result in death or serious injury.

**CAUTION:** A potentially hazardous situation that, if not avoided, could result in moderate injury or serious property damage.

**NOTE:** Information that will prevent premature equipment failure or minor property damage.

**WARNING:** This product can expose you to chemicals including lead and lead compounds which are known to the State of California to cause cancer and birth defects or other reproductive harm. For more information go to [www.P65Warnings.ca.gov](http://www.P65Warnings.ca.gov).

**WARNING:** This machine is not equipped with explosion proof motors. Never use near flammable or reactive materials, liquids, vapors or combustible dusts. Electric motors spark internally during operation and could cause a flash fire or explosion.

**WARNING:** Never circumvent safety devices such as circuit breakers or fuses.

**WARNING:** Keep batteries away from sparks and open flame.

**WARNING:** Do not smoke near the machine.

**WARNING:** Do not plug in the battery charger cable if wall cord or any electrical system components are damaged.

**WARNING:** Disconnect battery cables before servicing.

**WARNING:** Do not wear jewelry when working near moving or electrical components.

**WARNING:** Do not use the machine as a means for transport.

**WARNING:** Never allow children to play on or around machine.

**WARNING:** Do not operate the machine:

- Unless trained and authorized.
- Unless operator manual has been fully read and understood.
- Under the influence of drugs or alcohol.
- With any part of the machine not functioning properly, including electrical or mechanical safety devices.
- In areas where flammable vapors, liquids, or combustible dusts are present.

**WARNING:** While operating the machine:

- Operate the machine only as described in this manual.
- Follow all safety instructions and guidelines specific to your facility or environment.

**CAUTION:** Do not modify the machine from its original design.

**CAUTION:** Wear non-slip shoes when operating the machine.

**CAUTION:** Only use Bromine in your Tank Treatment System. Do not use Chlorine! Chlorine can interact with ammonia-based detergents and cause harmful fumes.

**CAUTION:** Follow mixing and handling instructions on chemical containers.

**CAUTION:** Service the machine on a level surface with the machine turned off and power disconnected.

**CAUTION:** Avoid moving parts and do not wear loose jackets, shirts, or sleeves when servicing.

**CAUTION:** Two-person lift required.

**NOTE:** Avoid heavy wash-downs and do not use a power-sprayer on the machine. Electrical malfunction may occur.

**NOTE:** All repairs must be performed by a qualified service technician using approved replacement parts.

**NOTE:** Discontinue use and report machine damage or faulty operation immediately.

**NOTE:** Store the machine indoors where the temperature is between 32° and 104°F (0° and 40°C).

**NOTE:** Do not use an extension cord. This will void the warranty on the battery charger.

**NOTE:** Only use prescribed replacement batteries.

**NOTE:** Ensure battery charging and storage locations comply with OSHA and any governing agencies' standards based on your particular location and application.

**NOTE:** When loading/unloading machine for transport:

- Fully drain the solution and recovery tanks before loading.
- Apply caster brakes and tie down the machine.

**NOTE:** Use of caustic, high-ph, or degreasing chemicals can decrease the service life of components.

**NOTE:** Do not use more than one Q-CAPS™ container per full tank of fresh water.

**NOTE:** Q-CAPS™ are eco-friendly chemicals and are not subject to Prop 65 of California.

**NOTE:** This machine is not designed to be used as a dry vacuum. Operate the machine only as described in this manual.

**PAGE INTENTIONALLY BLANK**

# MACHINE OVERVIEW

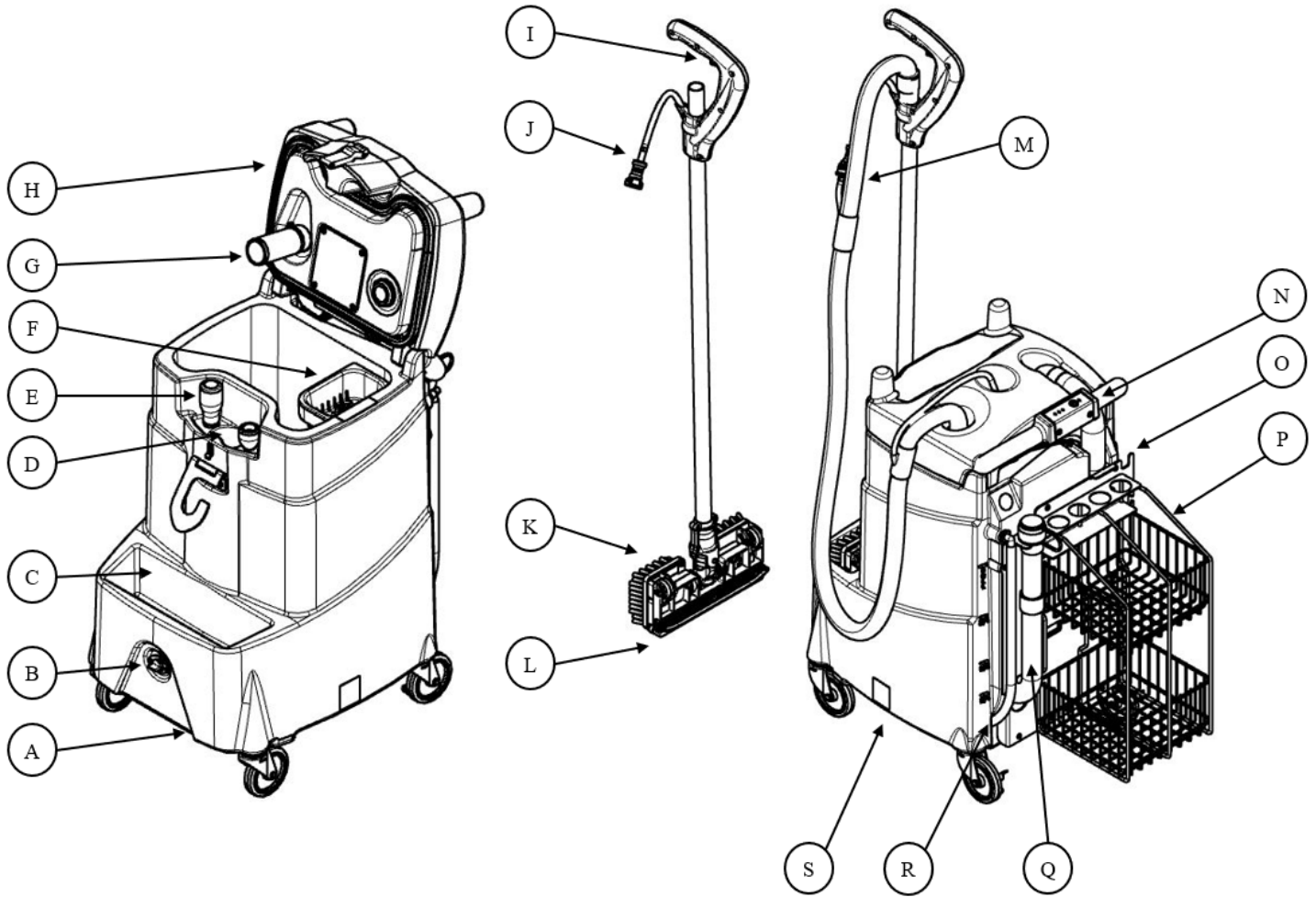

A. TANK ASSEMBLY

B. SCRUB BRUSH STORAGE AREA DRAIN

C. SCRUB BRUSH STORAGE AREA

D. FRONT SOLUTION TANK FILL PORT

E. Q-CAPST<sup>™</sup> CHEMICAL SYSTEM

F. DEBRIS TRAY ASSEMBLY

G. BALL FLOAT SHUT-OFF

H. COVER ASSEMBLY

I. SOLUTION TRIGGER

J. SOLUTION HOSE QUICK-DISCONNECT

K. BRUSH (OR SCRUB PAD) ASSEMBLY

L. SQUEEGEE ASSEMBLY

M. DUAL VACUUM-SOLUTION HOSE

N. OPERATOR CONTROL PANEL

O. BATTERY CHARGER CORD STORAGE

P. OPTIONAL STORAGE CADDY

Q. RECOVERY TANK DRAIN HOSE

R. SOLUTION TANK SIGHT TUBE

S. SOLUTION TANK FILTER & SCREEN

# OPERATION

Prior to use, ensure the battery has been sufficiently charged. The machine should be plugged in for charging any time the machine is not in use. The QS-12 is not designed to pick up large particles. Sweep and remove any large debris from the area to be cleaned before operation.



Fill the Solution Tank with fresh water using the Solution Tank fill ports located on the front (under the Cover Assembly) or rear of the machine. Water temperature should not exceed 120°F (50°C). If the Q-CAPS™ chemical system is being utilized, install the appropriate Q-CAPS™ container at this time.



Turn the machine on using the On/Off switch located on the Operator Control Panel.



Remove the Handle–Scrub Brush Assembly from its storage area.



With the scrub brush (or scrub pad) facing downwards, depress the solution trigger located on the handle. Apply enough solution to adequately wet the area to be cleaned. Note: To prevent slip and fall accidents, it's best to clean larger areas in small sections.

Note: The Vacuum Motor is disabled whenever the Solution Pump is in use. Release Solution Trigger to activate Vacuum Motor.

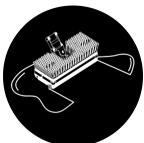

Once the area has been thoroughly scrubbed, flip the Scrub Brush Assembly over so that the squeegee is facing downwards. Vacuum until the area is dry.



Return the Handle–Scrub Brush Assembly to the storage area. Note: The Handle-Scrub Brush Assembly may retain a small amount of recovered solution. Storing the assembly before turning off the machine ensures this liquid drains into the storage area instead of draining onto the clean floor.



Turn the machine off using the On/Off switch located on the Operator Control Panel.



Using the Recovery Tank Drain Hose located on the rear of the machine, empty the recovered solution into an approved drain or slop sink.

# INSPECTION & CLEANING

## Flushing the Solution Tank

If a large amount of debris gets into the Solution Tank, it will be necessary to flush the tank.

1. Remove the Filter Bowl and Screen located on the bottom of the machine.
2. Flush the tank by running clean water into the front or rear solution fill ports until all debris is removed.
3. Reinstall Filter Screen and Bowl.



## Cleaning the Dual Hose

Cleaning of the recovery portion of the Dual Hose should be performed regularly to avoid poor performance and foul odors.

1. Disconnect the Dual Hose from the Handle Assembly.
  - i. Separate the solution side of the Dual Hose using the quick-disconnect.
  - ii. Remove the cuff of the Dual Hose from the tube of the Handle Assembly.

**NOTE:** Do not remove the Dual Hose from the Cover Assembly unless to replace the Dual Hose assembly.

2. Flush clean water into the end of the Dual Hose, allowing the water to flow into the Recovery Tank.
3. Reconnect the Dual Hose after cleaning.

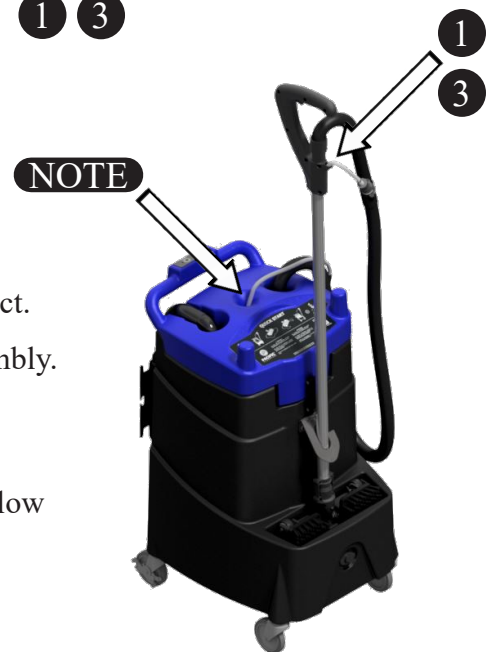

## Cleaning the Recovery System

Cleaning of the Recovery System should be performed regularly to avoid poor performance and foul odors.

1. Lower the Recovery Tank Drain Hose (located at the back of the machine) into an approved drain or slop sink and remove the cap.
2. Allow any recovered solution in the tank to drain. Rinse the Recovery Tank thoroughly. Wipe out any remaining sediment.
3. Clean the Debris Tray and inspect the Bromine puck. If necessary, replace the Bromine puck to ensure optimal odor reduction.
4. Inspect and clean the Cover Assembly seal to ensure optimal vacuum is maintained.
5. Clean the ball float shut-off.
6. Leave the Cover Assembly open to dry.





## Inspecting and Cleaning the Scrub Brush Assembly

To ensure optimal performance, inspect and clean the Scrub Brush Assembly on a regular basis.

1. Check for excessive wear of the squeegee blades.
2. Replace worn scrub brushes or pads.

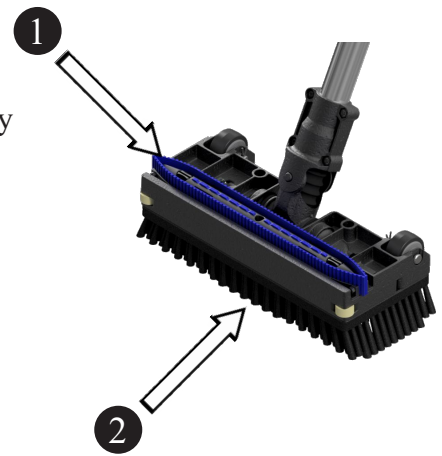

## SQUEEGEE & BRUSH ASSEMBLY REPLACEMENT

The Squeegee and Brush assemblies can be removed by turning the two quarter-turn fasteners located in each assembly. Use a large flat head screwdriver or similar tool.

Before installing the new Squeegee assembly, ensure the two factory-installed gaskets are in place and are in good condition.

Install and secure the new assembly using the quarter-turn fasteners.

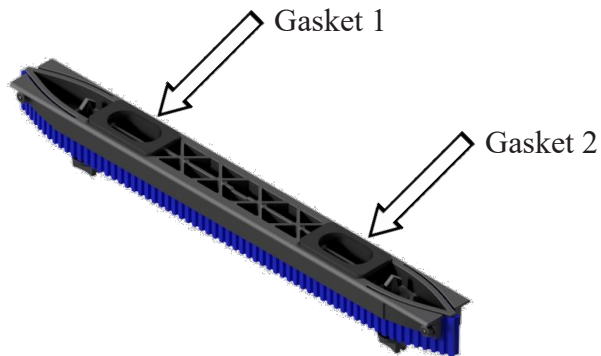

# BATTERY & CHARGING

## Battery Level

The current battery charge level is displayed on the Operator Control Panel whenever the machine is turned on. This is indicated by a red, yellow, and green LED.

- Green–Yellow–Red: Indicates approximately 100% – 56% battery remaining.
- Yellow–Red: Indicates approximately 55% – 1% battery remaining.
- Red Only: Indicates 0% battery remaining (the machine will no longer operate).



## Battery Charger & Charger Status

- A. The Battery Charger cord is stored on the cord wrap located on the rear right-hand side of the machine (cord not shown).
- B. The status of the battery charger is displayed through a small window in the back panel of the machine. The status indicator is active whenever the Battery Charger is plugged in.
- C. The battery charger on the QS-12 should be plugged into to 120 VAC, 60 hz power whenever the unit is not in use.

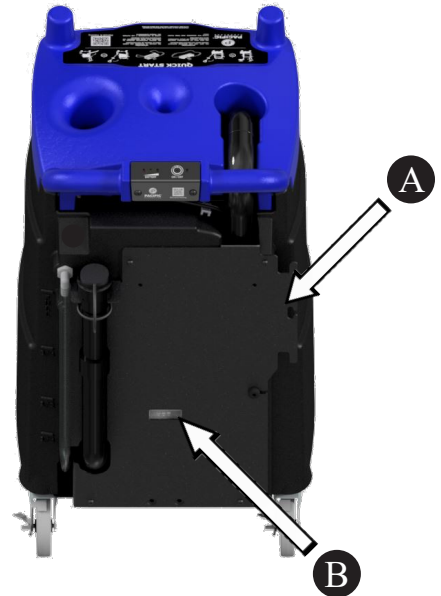

# SOLUTION TANK & Q-CAPS™ CHEMICAL SYSTEM

## Filling the Solution Tank

The Solution Tank can be filled through the front or rear fill ports. The front fill port is located under the Cover Assembly. The rear fill port is located above the Solution Tank Sight Tube and the Recovery Tank Drain Hose.

## Q-CAPS™ Chemical System

The Q-CAPS™ Chemical System allows for a pre-measured amount of cleaning chemical to be added to the Solution Tank. To use this system, simply thread a new Q-CAPS™ container onto the brass fitting located next to the front fill port. Q-CAPS™ containers are intended to be added to a fresh, full tank of water. Over-dosing (using more than one Q-CAPS™ container) could create poor results.



# RECOMMENDED MAINTENANCE

SYSTEM	DAILY	WEEKLY	MONTHLY	BI-ANNUALLY
<b>CONTROL PANEL</b>				
INSPECT ALL CONTROLS AND HARDWARE FOR SECURITY & SERVICEABILITY	X			
VERIFY PROPER OPERATION OF ALL CONTROLS	X			
<b>SOLUTION DISTRIBUTION</b>				
VERIFY SOLUTION FLOW	X			
FLUSH TANK WITH FRESH WATER			X	
INSPECT SOLUTION SUPPLY HOSES FOR LEAKS				X
<b>SCRUB TOOL</b>				
RINSE BRUSH/PADS	X			
RINSE & DRY SCRUB HEAD	X			
CLEAN & INSPECT SQUEEGEE ASSEMBLY	X			
INSPECT SCRUB HEAD U-JOINT HOSE FOR WEAR/DAMAGE		X		
INSPECT QUICK-DISCONNECT FOR LEAKS OR DAMAGE		X		
<b>RECOVERY SYSTEM</b>				
RINSE & AIR DRY RECOVERY TANK	X			
CLEAN & SANITIZE RECOVERY TANK			X	
CLEAN & INSPECT DEBRIS TRAY	X			
INSPECT / REPLACE BROMINE PUCK		X		
INSPECT LID SEAL		X		
VERIFY DRAIN HOSE CAP IS SEALED TIGHT WHEN INSTALLED	X			
INSPECT VACUUM HOSES FOR WEAR/DAMAGE		X		
RINSE SCRUB TOOL STORAGE COMPARTMENT	X			
CLEAN & SANITIZE SCRUB TOOL STORAGE COMPARTMENT			X	
<b>ELECTRICAL SYSTEMS</b>				
INSPECT BATTERY TERMINALS FOR SECURITY, CORROSION & DAMAGE				X
INSPECT BATTERY CHARGER POWER CORD FOR DAMAGE	X			
INSPECT ELECTRICAL WIRING FOR SECURITY, CORROSION & DAMAGE				X

**PAGE INTENTIONALLY BLANK**

# FRAME ASSEMBLY

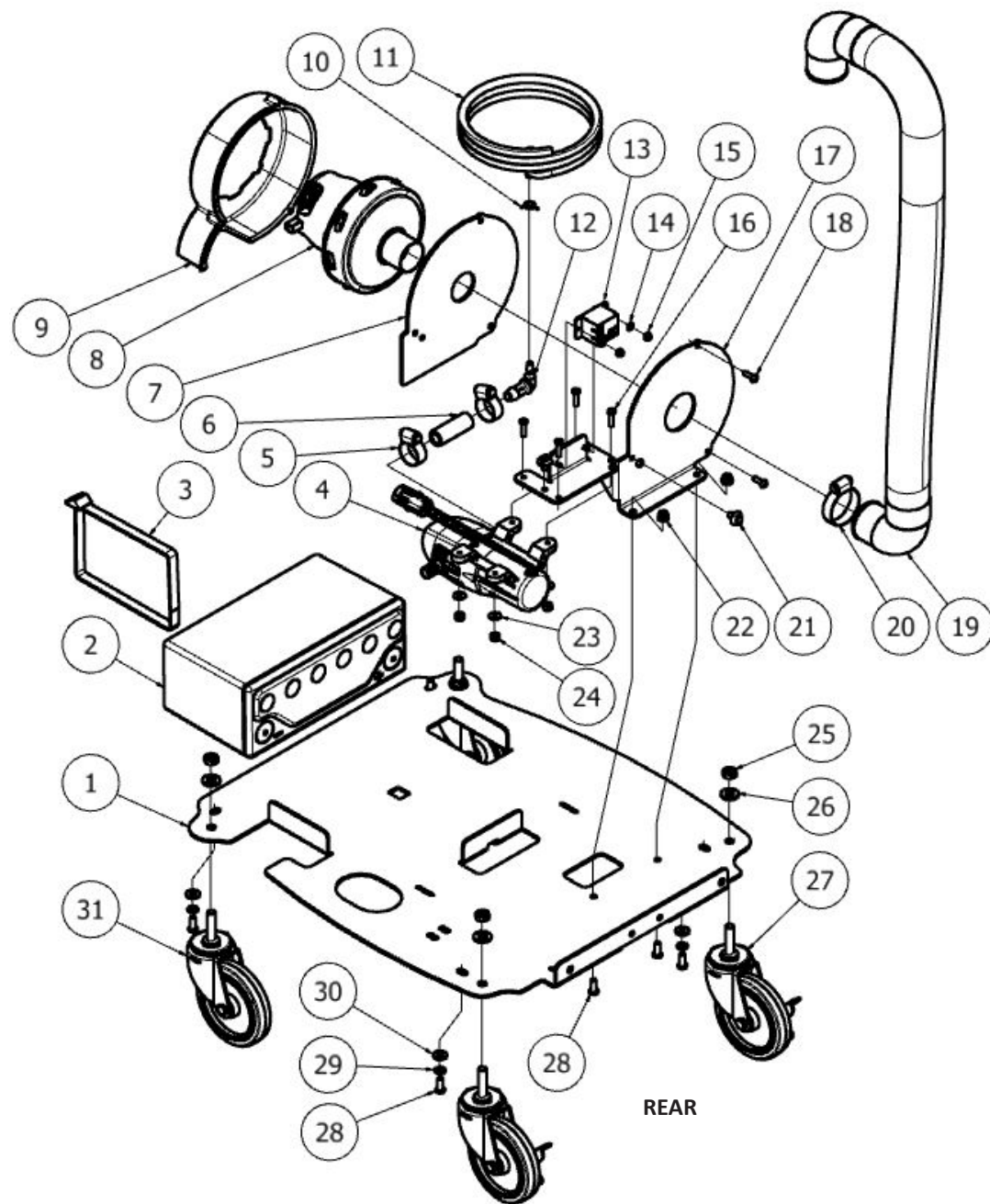

## FRAME ASSEMBLY

ITEM	WEAR ITEM	QTY	PART NUMBER	DESCRIPTION
1		1	803201	FRAME SCRUBBER S12
2		1	801302	BATTERY 12V 61AH TPPL
2		1	801301	BATTERY 12V 26AH TPPL
3		1	809207	TIE WIRE POLYPROPYLENE 22INCH
4		1	897006	PUMP SOLUTION 24VDC
5		2	S453P	CLAMP HOSE .44 - 1.0 SS
6		2"	224130	HOSE 1/2" DRAIN
7		1	803401	GASKET VACUUM ADHESIVE BACK
8		1	805201	MOTOR VACUUM 12V
9		1	801307	BRACE MOTOR VACUUM
10		2	872003	CLAMP, HOSE, .38, WIRE
11	*	44"	204179	1/4 VINYL TUBING
12		1	803307	FITTING ELBOW BARBED .5 X .25 TUBE
13		1	911767	RELAY 12VDC SPST-NO CHASSIS MOUNT
14		2	980082	WASHER FLAT #8 SS
15		2	920034	NUT HEX 6-32 NYLOCK SS
16		4	962003	SCREW PHPS 10-32 X .75 ZINC

ITEM	WEAR ITEM	QTY	PART NUMBER	DESCRIPTION
17		1	800802	BRACKET MTG VACUUM
18		3	964224	SCREW PHPS M5.5 X 16 ZINC PLASTIC
19	*	1	804102	HOSE VACUUM S12
20		1	S611A	CLAMP HOSE 1.0 - 2.0 SS
21		2	895601	MOUNT WIRE-TIE PRESS IN
22		2	920011	NUT HEX .25-20 NYLOCK ZINC
23		4	W401D	WASHER, FLAT, #10
24		4	920667	NUT HEX 10-32 NYLOCK SS BL
25		4	920032	NUT HEX .38-16 NYLOCK ZINC THIN
26		4	980003	WASHER, FLAT, .38
27	*	2	809704	CASTER 4IN URETHANE W BRK
28		6	962263	SCREW BHCS .25-20 X .63 SS BL
29		4	980002	WASHER, LOCK, SPLIT, .25
30		4	W104D	WASHER, FLAT, .25
31	*	2	809703	CASTER 4IN URETHANE NON-BRAKE
32		1	911761	HARNESS POWER S12 (NOT SHOWN)

\* BATTERY (ITEM 2) DEPENDENT ON MODEL.

\*\* WIRE TIE (ITEM 3) ONLY USED WITH 26 AH BATTERY.

# TANK ASSEMBLY

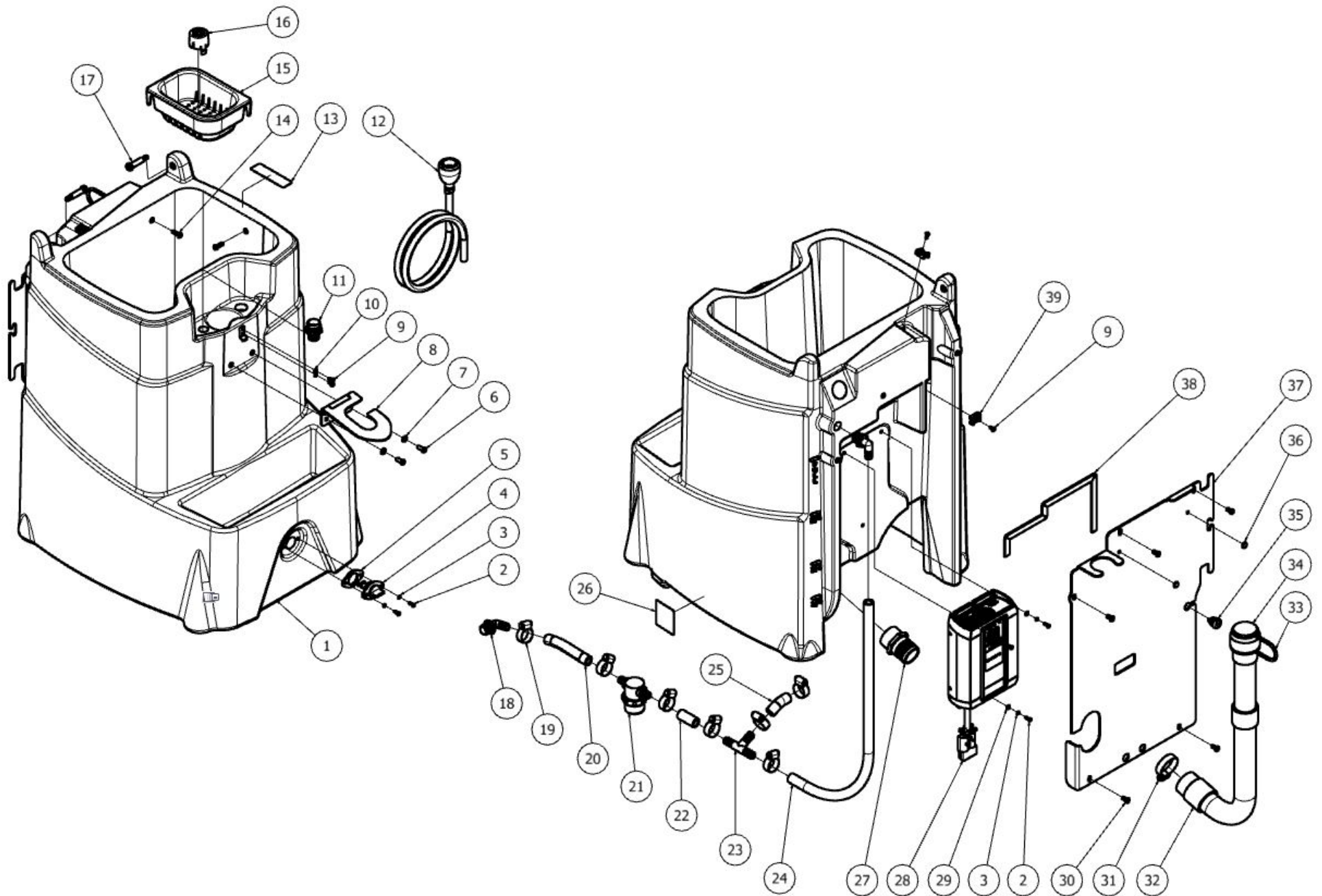



# TANK ASSEMBLY

ITEM	WEAR ITEM	QTY	PART NUMBER	DESCRIPTION
1		1	808601	TANK SOLUTION S12
2		5	962230	SCREW BHCS 8-32 X 0.5 SS BL
3		5	980083	WASHER SPLIT LOCK #8 SS
4		1	809402	VALVE DRAIN
5		1	803412	GASKET DRAIN VALVE
6		2	962263	SCREW BHCS .25-20 X .63 SS BL
7		2	980002	WASHER, LOCK, SPLIT, .25
8		1	804103	HINGE RETAINING WAND
9		4	962063	SCREW PHPS 8-32 X .38 SS
10		2	980026	WASHER, LOCK, #8 INT TOOTH
11		1	803303	FITTING NPT DIN28
12	*	1	804109	HOSE FILL UNIVERSAL
13		1	875110	LABEL, INSTRUCT, BROMINE
14		2	962440	SCREW BHCS .25-20 X .75 SS PATCH
15		1	809201	TRAY DEBRIS SCRUBBER
16		1	879202	TRAY, PUCK
17		2	962441	SCREW SHSS .31-18 X 1.25 SS PATCH
18		2	803308	FITTING ELBOW .5 NPT .5 BARB
19		7	S453P	CLAMP HOSE .44 - 1.0 SS

\* FITTING (ITEM 11) ONLY USED ON SELECT MODELS.

\* FILL HOSE (ITEM 12) ONLY USED ON SELECT MODELS.

ITEM	WEAR ITEM	QTY	PART NUMBER	DESCRIPTION
20		4.5"	224130	TUBE SIGHT .50 ID
21		1	843319	FILTER, SCREEN, BOWL
22		1.63"	224130	TUBE SIGHT .50 ID
23		1	873308	FITTING, TEE, 0.50 INCH
24	*	26"	224130	TUBE SIGHT .50 ID
25		2.13"	224130	TUBE SIGHT .50 ID
26		1	895115	LABEL LOCATION FILTER
27		1	853304	FITTING, STR, BM24, PM20
28		1	802401	CHARGER 12V 13AMP
29		3	980082	WASHER FLAT #8 SS
30		5	962250	SCREW BHCS .25-20 X .50 SS BL
31		1	S611A	CLAMP HOSE 1.0 - 2.0 SS
32	*	1	804101	HOSE DRAIN 1.5INCH
33	*	1	858506	STRAP SUPPORT HOSE - REPL
34	*	1	851501	CAP HOSE DRAIN-REPL
35		1	508519	STRAIN RELIEF-HEYCO #SR 6
36		2	806804	PLUG HOLE .25IN PLASTIC BL
37		1	807004	PANEL BACK S12
38	*	1	803411	GASKET BACK PANEL
39		2	225670	PAD, WIRE TIE

\*\* HOLE PLUG (ITEM 36) ONLY USED ON SELECT MODELS.

# COVER ASSEMBLY

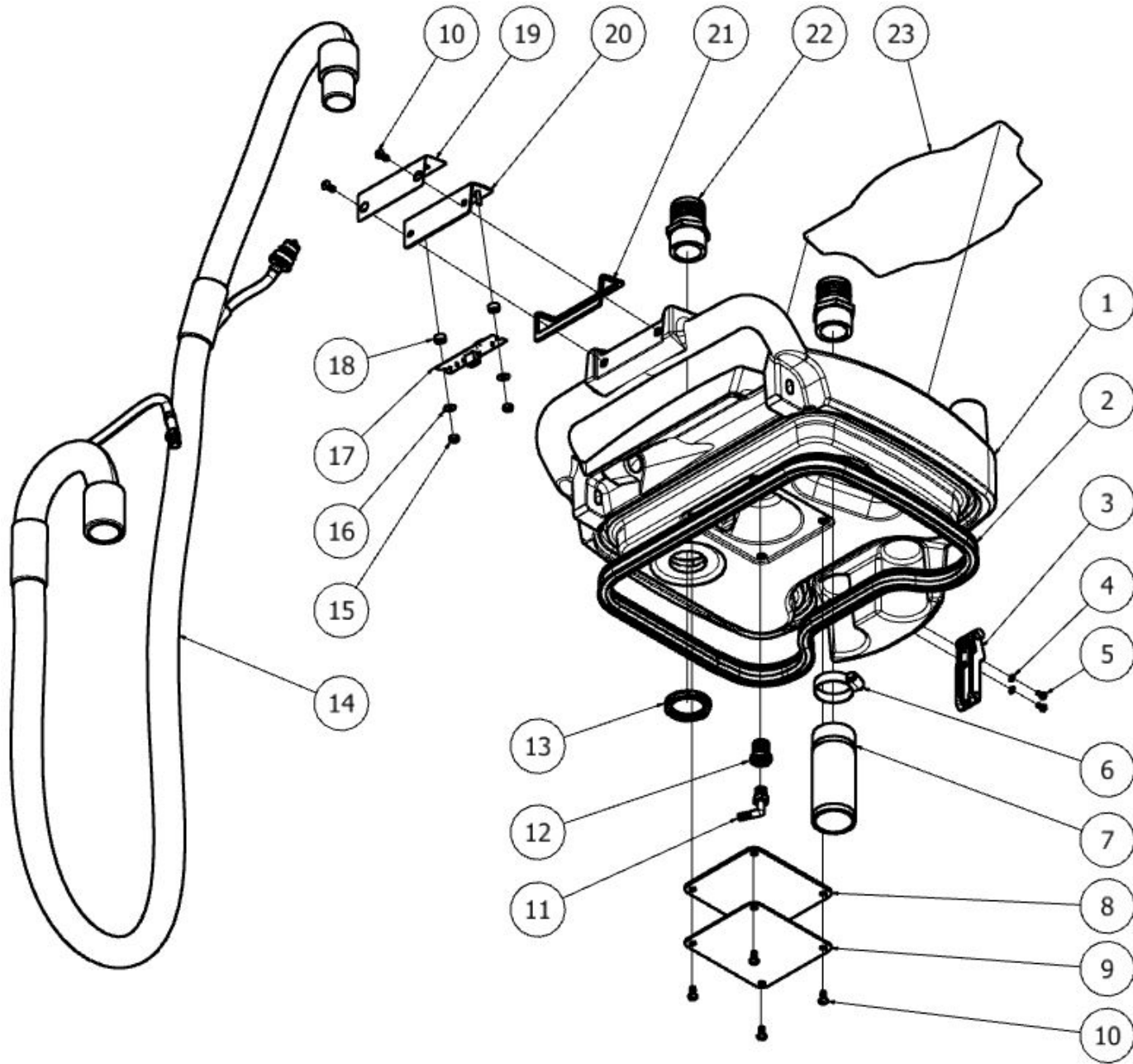

## COVER ASSEMBLY

ITEM	WEAR ITEM	QTY	PART NUMBER	DESCRIPTION
1		1	802301	COVER TANK S12
2		1	853401	GASKET, COVER, PRESS-IN
3		1	695102	CLAMP OVER-CENTER RUBBER
4		2	980026	WASHER, LOCK, #8 INT TOOTH
5		2	962063	SCREW PHPS 8-32 X .38 SS
6		1	5611A	CLAMP HOSE 1.0 - 2.0 SS
7		1	223370	FLOAT, SHUTOFF
8	*	1	803402	GASKET COVER FITTING
9		1	802302	COVER FITTING
10		6	962250	SCREW BHCS .25-20 X .50 SS BL
11		1	533302	FITTING ELBOW .25NPT .25 BARB NYL
12		1	803305	FITTING THRU-WALL THREADED .25 NPT BRASS
13		1	920705	NUT 1.25 NPT PLASTIC
14	*	1	805008	KIT DUAL HOSE REPL
15		2	920667	NUT HEX 10-32 NYLOCK SS BL
16		2	980022	WASHER, LOCK, SPLIT, #10
17		1	807003	CONTROLLER OPERATOR QS-12
18		2	898209	SPACER ACTUATOR PLASTIC
19		1	805102	LABEL CONTROL S12
20		1	807002	PANEL CONTROL S12
21		1	803410	GASKET CONTROL PANEL
22		2	853304	FITTING, STR, BM24, PM20
23		1	805101	LABEL INFORMATION S12
24		1	911762	HARNESS MAIN S12 (NOT SHOWN)

# HANDLE ASSEMBLY

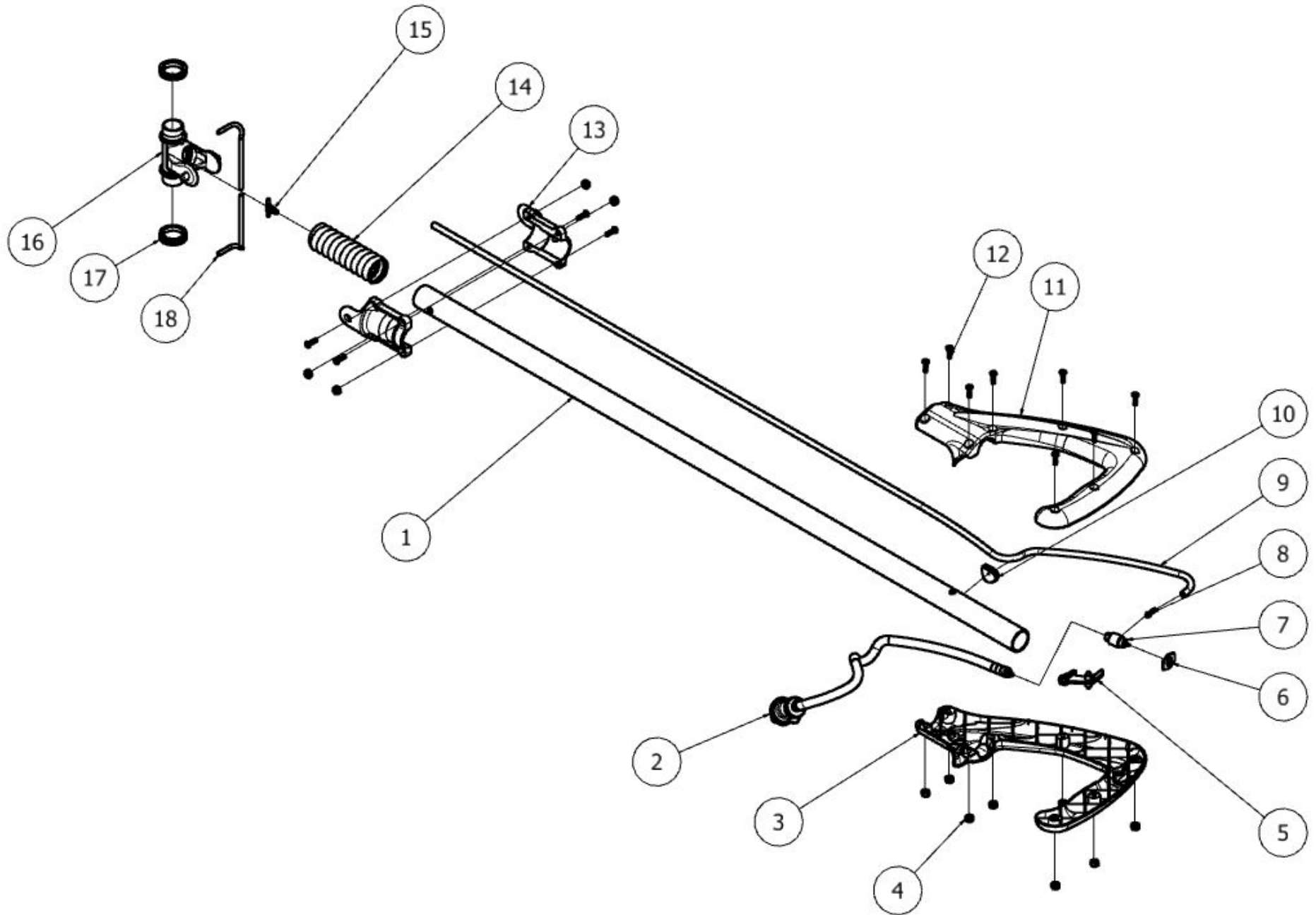

## HANDLE ASSEMBLY

ITEM	WEAR ITEM	QTY	PART NUMBER	DESCRIPTION
1		1	809001	TUBE HANDLE S12
2	*	1	805007	KIT HOSE QD ASSEMBLY REPL
3		1	803903	HANDLE TOOL QS-12 RH
4		12	920667	NUT HEX 10-32 NYLOCK SS BL
5		1	809206	TRIGGER SOLUTION QS-12
6		1	806401	PLATE MTG VALVE
7		1	809401	VALVE SOLUTION MANUAL
8		1	803313	FITTING ADAPTER .156 BARB 10-32
9		72"	804107	HOSE FLEXIBLE .188 ID .25 OD PVC
10	*	2	803407	GASKET S-12 HEAD AND HANDLE
11		1	803904	HANDLE TOOL QS-12 LH
12		12	962563	SCREW BHCS 10-32 X .63 SS BL
13		2	800202	ADAPTER HANDLE S12
14	*	1	804105	HOSE U-JOINT FLEXIBLE
15		1	803310	FITTING TEE .19 X .13
16		1	809202	TEE PIVOT HANDLE S12
17		2	807601	SEAL PIVOT VACUUM
18	*	12"	804108	HOSE .13 ID .19 OD PVC

# SCRUB HEAD ASSEMBLY

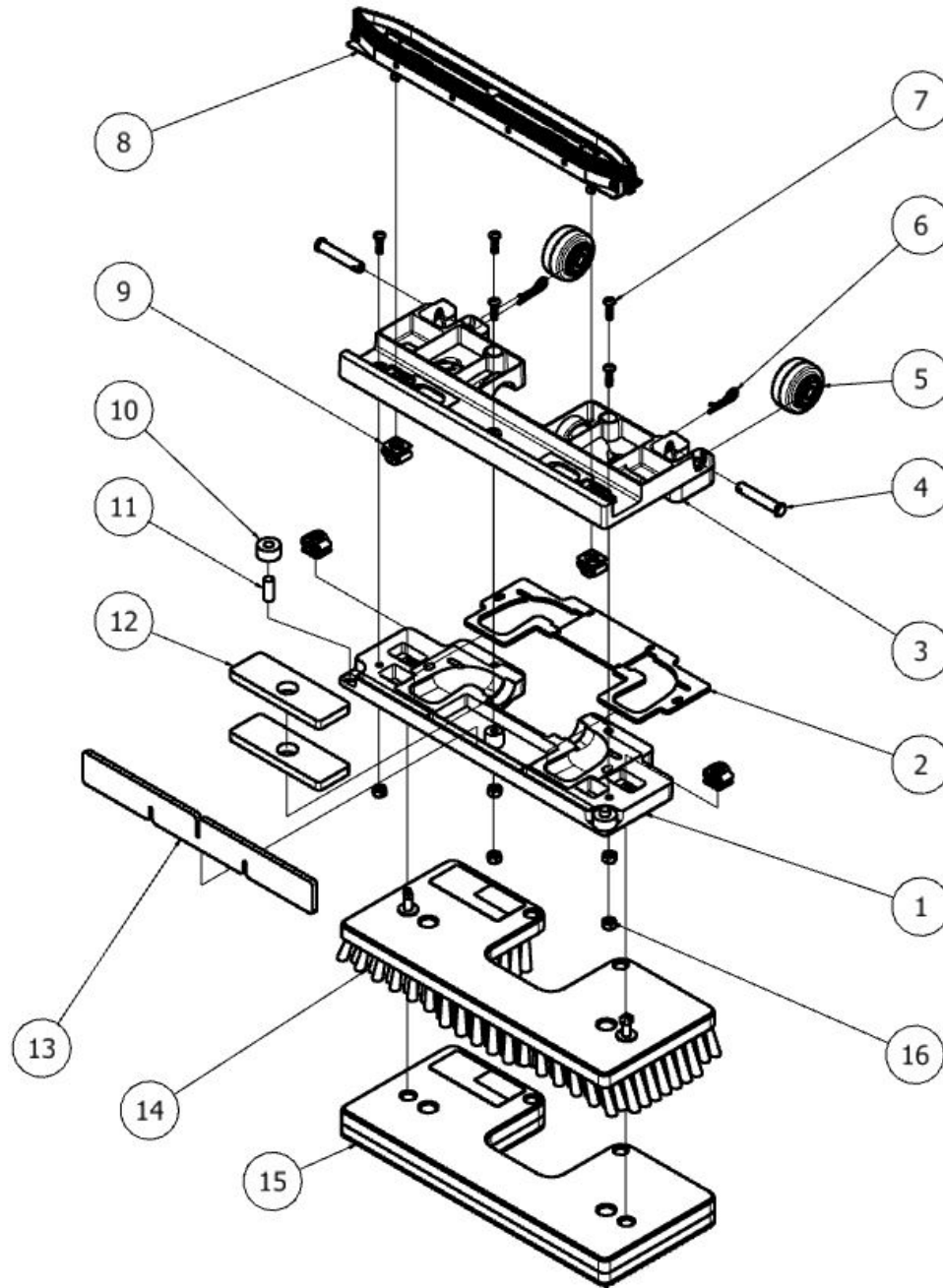

# SCRUB HEAD ASSEMBLY

ITEM	WEAR ITEM	QTY	PART NUMBER	DESCRIPTION
1		1	801304	BASE BRUSH S12
2		1	803407	GASKET S-12 HEAD AND HANDLE
3		1	801305	BASE SQUEEGEE S12
4		2	925013	PIN CLEVIS .313 X 1.5 SS
5	*	2	809702	WHEEL 1.63 OD .31 ID
6		2	925014	PIN COTTER .08 DIA. X 1.25 SS
7		5	962563	SCREW BHCS 10-32 X .63 SS BL
8	*	1	805004	KIT SQUEEGEE ASSEMBLY REPL
9	*	4	807202	RETAINER KNOB QUARTER-TURN
10	*	2	807501	ROLLER .75 OD PLASTIC
11	*	2	806701	PIN DOWEL .31 OD
12		2	806402	PLATE WEIGHT S12
13		1	806403	PLATE WEIGHT LARGE S12
14	*	1	805005	KIT BRUSH ASSEMBLY
15	*	1	805006	KIT PAD HOLDER ASSEMBLY
16		5	920667	NUT HEX 10-32 NYLOCK SS BL

\* PAD HOLDER ASSEMBLY (ITEM 15) ONLY USED ON SELECT MODELS.

# STORAGE CADDY ASSEMBLY

(ONLY USED ON SELECT MODELS)

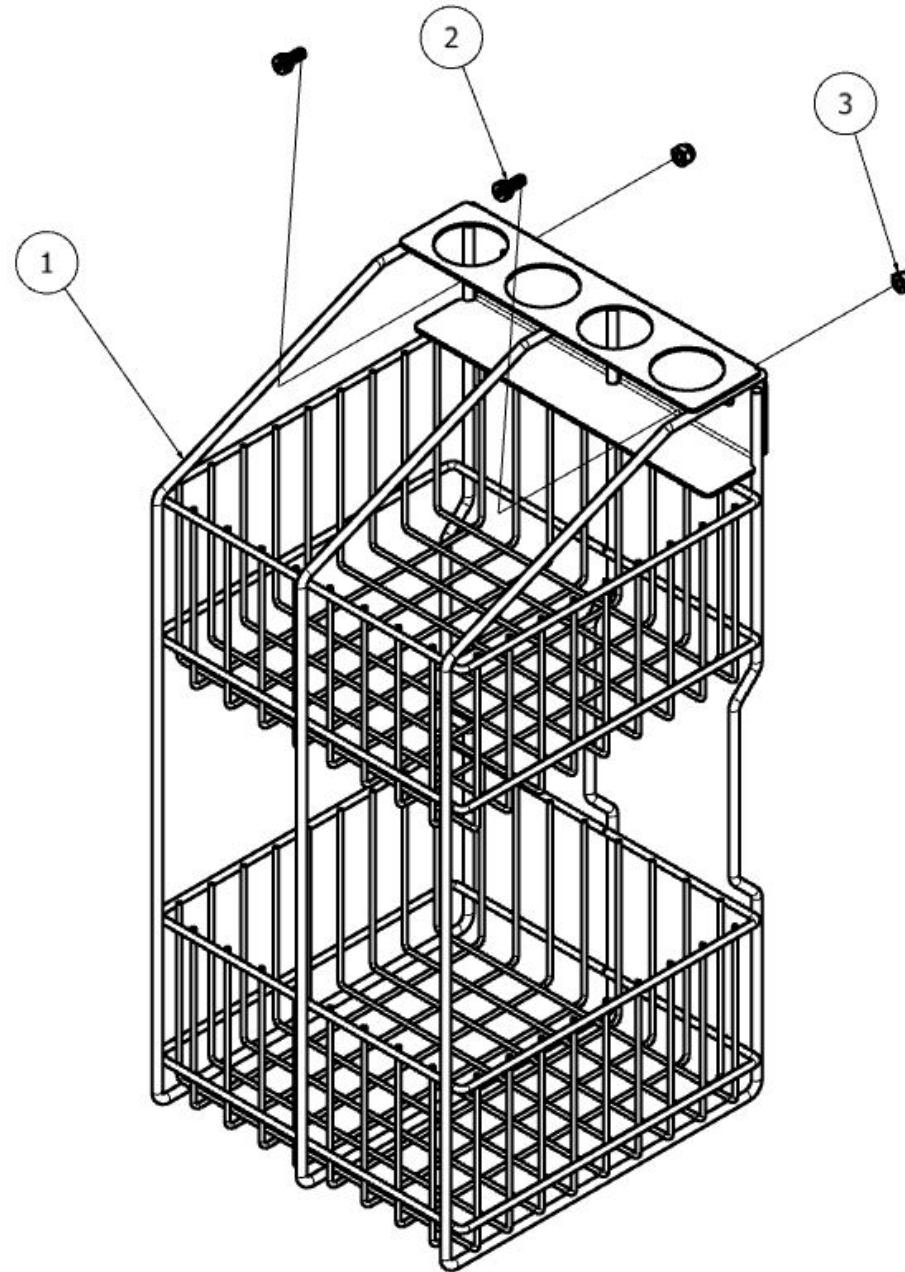



## STORAGE CADDY ASSEMBLY (ONLY USED ON SELECT MODELS)

ITEM	WEAR ITEM	QTY	PART NUMBER	DESCRIPTION
1		1	809203	TRAY ACCESSORY S12
2		2	962439	SCREW SHLDR .31 DIA X .13 .25-20 BL
3		2	920011	NUT HEX .25-20 NYLOCK ZINC

\* STORAGE CADDY ASSEMBLY CAN BE ORDERED AS AN AFTERMARKET ACCESSORY UNDER PART NUMBER 805011.

# ADJUSTABLE HANDLE ASSEMBLY (AFTERMARKET ACCESSORY)

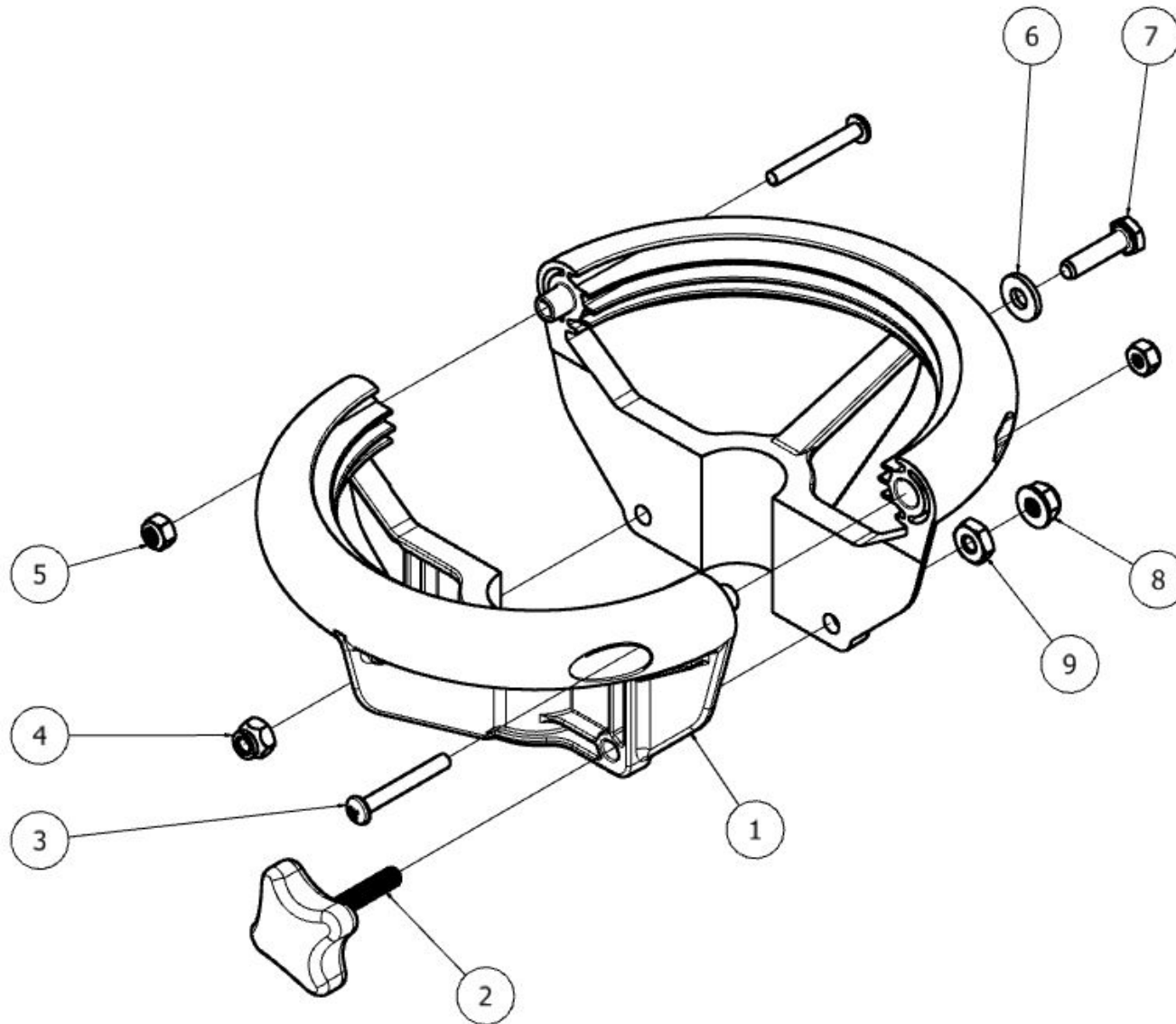

## ADJUSTABLE HANDLE ASSEMBLY (AFTERMARKET ACCESSORY)

ITEM	WEAR ITEM	QTY	PART NUMBER	DESCRIPTION
1		2	803902	HANDLE CENTER ADJ
2		1	805003	KNOB THREADED .25-20
3		2	962146	SCREW PHPS 10-32 X 1.5 ZINC
4		1	920665	NUT HEX .25-20 NYLOCK SS
5		2	920667	NUT HEX 10-32 NYLOCK SS BL
6		1	W104D	WASHER, FLAT, .25
7		1	962221	SCREW HH .25-20 X 1.0 SS
8		1	920020	NUT .25-20 NYLOCK FLANGED SS
9		1	920037	NUT HEX .25-20 SS THIN

\* ADJUSTABLE HANDLE ASSEMBLY CAN BE ORDERED AS AN AFTERMARKET ACCESSORY UNDER PART NUMBER 805010.

## ELECTRICAL COMPONENTS LIST

PART NUMBER	DESCRIPTION	APPLICATION	CONNECTIONS
911768	FUSE AUTOMOTIVE 25A	CIRCUIT PROTECTION	FUSE HOLDER IN POWER HARNESS
911767	RELAY 12VDC SPST-NO CHASSIS MOUNT	VACUUM MOTOR OPERATION	POWER HARNESS
911762	HARNESS MAIN S12	SIGNAL HARNESS	OPERATOR CONTROL PANEL TO POWER HARNESS, BATTERY CHARGER
911761	HARNESS POWER S12	POWER HARNESS	BATTERY, PUMP, VAC MOTOR, BATTERY CHARGER TO MAIN HARNESS
897006	PUMP SOLUTION 24VDC	SOLUTION SUPPLY	MAIN HARNESS
807003	CONTROLLER OPERATOR QS-12	OPERATOR CONTROLS	MAIN HARNESS
805201	MOTOR VACUUM 12VDC	VACUUM	MAIN HARNESS
802401	CHARGER 12V 13AMP	BATTERY CHARGER	AC POWER, POWER HARNESS, MAIN HARNESS
801302	BATTERY 12V 61AH TPPL	POWER SUPPLY	MAIN HARNESS
801301	BATTERY 12V 29AH TPPL	POWER SUPPLY	MAIN HARNESS

# ELECTRICAL DIAGRAM

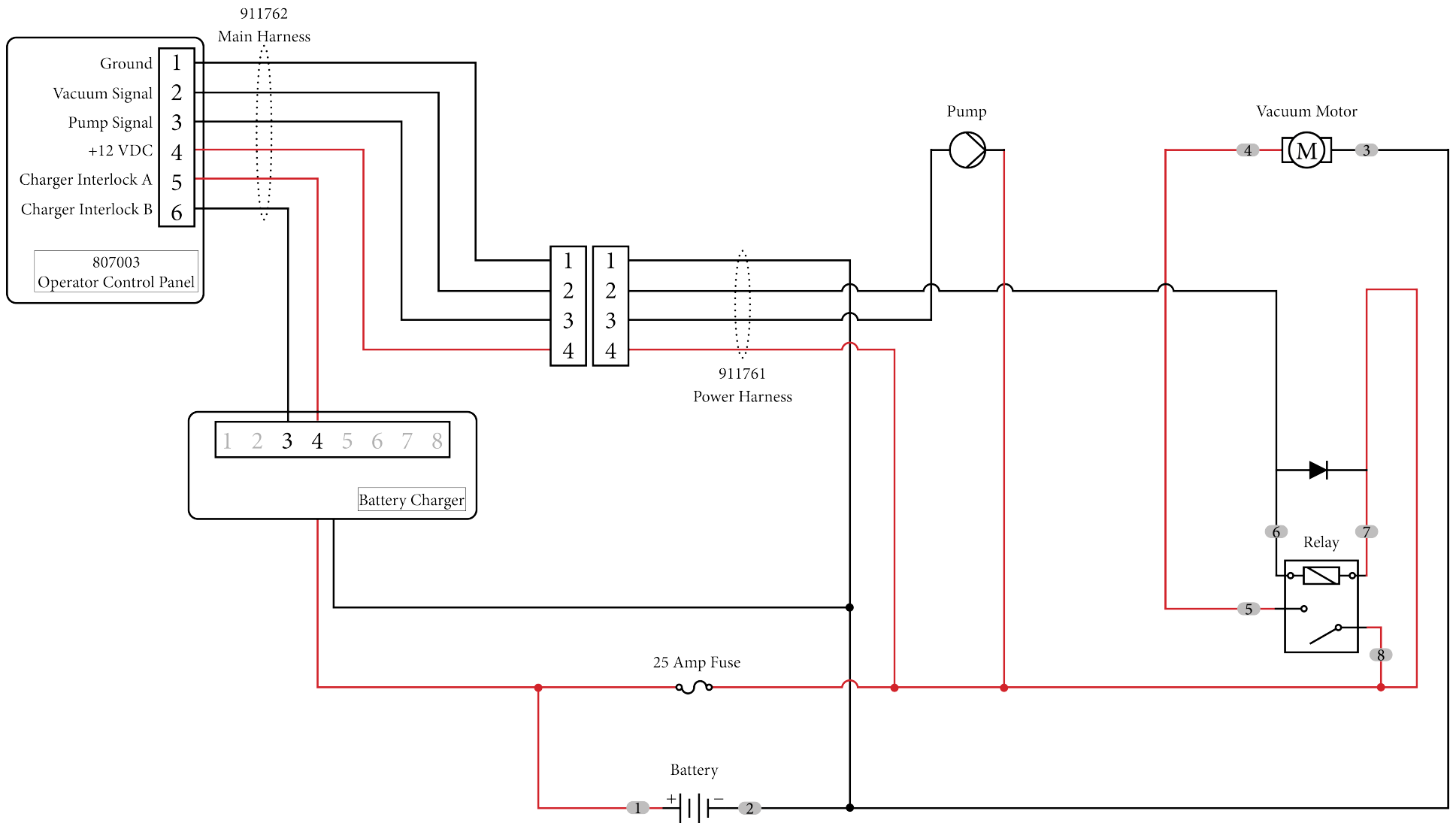

**Notes:**

1. Wires 3 & 4 can be reversed without affecting function.
2. Wires 5 & 8 can be reversed without affecting function.
3. Wires 6 & 7 can be reversed without affecting function.
4. Diode polarity between wires 6 & 7 is critical.



**PAGE INTENTIONALLY BLANK**



**PACIFIC**<sup>®</sup>  
F L O O R C A R E

**PURPOSE BUILT.**<sup>®</sup>

[www.pacificfloorcare.com](http://www.pacificfloorcare.com)